

ABB industrial drives

Hardware manual

ACS880-07 drives (560 to 2800 kW)



Power and productivity
for a better world™



List of related manuals

Drive hardware manuals and guides

Code (English)

<i>ACS880-07 (560 to 2800 kW) hardware manual</i>	3AUA0000143261
<i>ACS-AP-X assistant control panels user's manual</i>	3AUA0000085685

Drive firmware manuals and guides

<i>ACS880 diode supply control program firmware manual</i>	3AUA0000103295
<i>ACS880 primary control program firmware manual</i>	3AUA0000085967
<i>Quick start-up guide for ACS880 drives with primary control program</i>	3AUA0000098062

Option manuals and guides

<i>Drive composer start-up and maintenance PC tool user's manual</i>	3AUA0000094606
<i>FSO-12 safety functions module user's manual</i>	3AXD50000015612
<i>User's manual for Prevention of unexpected start-up (+Q950) for ACS880-07/17/37 drives</i>	3AUA0000145922
<i>User's manual for Emergency stop, stop category 0 (+Q951) for ACS880-07/17/37 drives</i>	3AUA0000119895
<i>User's manual for Emergency stop, stop category 1 (+Q952) for ACS880-07/17/37 drives</i>	3AUA0000119896
<i>User's manual for Prevention of unexpected start-up (+Q957) for ACS880-07/17/37 drives</i>	3AUA0000119910
<i>User's manual for Emergency stop, stop category 0 (+Q963) for ACS880-07/17/37 drives</i>	3AUA0000119908
<i>User's manual for Emergency stop, stop category 1 (+Q964) for ACS880-07/17/37 drives</i>	3AUA0000119909
<i>User's manual for Emergency stop, configurable stop category 0 or 1 (+Q978) for ACS880-07/17/37 drives</i>	3AUA0000145920
<i>User's manual for Emergency stop, configurable stop category 0 or 1 (+Q979) for ACS880-07/17/37 drives</i>	3AUA0000145921
<i>Manuals and quick guides for I/O extension modules, fieldbus adapters, etc.</i>	

You can find manuals and other product documents in PDF format on the Internet. See section [Document library on the Internet](#) on the inside of the back cover. For manuals not available in the Document library, contact your local ABB representative.



[ACS880-07 \(560 to 2800 kW\)
manuals](#)

Hardware manual

ACS880-07 drives
(560 to 2800 kW)





Table of contents	
1. Safety instructions	
4. Mechanical installation	
6. Electrical installation	
9. Start-up	

Table of contents

1. Safety instructions

Contents of this chapter	15
Use of warnings and notes	15
General safety in installation, start-up and maintenance	16
Electrical safety in installation, start-up and maintenance	19
Precautions before electrical work	19
Additional instructions and notes	20
Grounding	21
Additional instructions for permanent magnet motor drives	22
Safety in installation, start-up and maintenance	22

2. Introduction to the manual

Contents of this chapter	23
Target audience	23
Contents of the manual	23
Related manuals	24
Categorization by frame size and option code	24
Quick installation, commissioning and operation flowchart	25
Terms and abbreviations	26
Safety data (SIL, PL)	27

3. Operation principle and hardware description

Contents of this chapter	29
Product overview	29
Overview circuit diagram of the drive	30
12-pulse connection (option +A004)	31
Cabinet line-up and layout examples	32
Frame 1×D8T + 2×R8i	32
Frame 2×D7T + 2×R8i (12-pulse connection, option +A004)	34
Frame 2×D8T + 3×R8i	36
Frame 3×D8T + 4×R8i (with main breaker, option +F255)	38
Auxiliary control cubicle (ACU) layout	40
Overview of power and control connections	42
Door switches and lights	44
Main disconnecting device (Q1.1)	45
Auxiliary voltage switch (Q21)	45
Grounding (earthing) switch (Q9.x), optional	45
Other devices on the door	45
Control panel	46
Control by PC tools	46
Descriptions of cabinet options	47
Degree of protection	47
Definitions	47
IP22 (standard)	47
IP42 (option +B054)	47
IP54 (option +B055)	47



Cooling air intake through bottom of cabinet (option +C128)	47
Channeled air outlet (option +C130)	47
Marine construction (option +C121)	48
UL Listed (option +C129)	48
CSA Approved (option +C134)	48
Plinth height (options +C164 and +C179)	48
Seismic design (option +C180)	48
Resistor braking (options +D150 and +D151)	48
EMC filters (option + E202)	49
Cabinet heater with external supply (option +G300)	49
Terminals for external control voltage (option +G307)	49
Output for motor space heater (option +G313)	49
Additional wire markings (options +G340 and +G342)	50
Cable conduit entry (option +H358)	50
Common motor terminal cubicle (option +H359)	50
Common output terminal (option +H366)	50
Additional terminal block X504 (option +L504)	51
Thermistor relays (options +L505, +2L505)	51
Pt100 relays (options +2L506, +3L506, +5L506, +8L506)	52
What the option contains	52
Description	52
Type designation label	53
Type designation key	53

4. Mechanical installation

Contents of this chapter	57
Examining the installation site	57
Necessary tools	58
Checking the delivery	58
Moving and unpacking the drive	59
Moving the drive in its packaging	59
Lifting the crate with a forklift	59
Lifting the crate with a crane	60
Moving the crate with a forklift	61
Removing the transport package	62
Moving the unpacked drive cabinet	62
Lifting the cabinet with a crane	62
Moving the cabinet on rollers	63
Moving the cabinet on its back	63
Final placement of the cabinet	64
Fastening the cabinet to the floor and wall or roof (non-marine units)	65
General rules	65
Fastening methods	66
Alternative 1 – Clamping	66
Alternative 2 – Using the holes inside the cabinet	66
Fastening the cabinet to the floor and roof/wall (marine units)	67
Joining shipping splits together	68
Miscellaneous	70
Cable duct in the floor below the cabinet	70
Air inlet through the bottom of cabinet (option +C128)	70
Air outlet duct on the cabinet roof (option +C130)	71
Calculating the required static pressure difference	71
Arc welding	72

5. Guidelines for planning the electrical installation

Contents of this chapter	73
Limitation of liability	73
Selecting the supply disconnecting device	73
Selecting the main contactor	73
Examining the compatibility of the motor and drive	74
Protecting the motor insulation and bearings	74
Requirements table	75
Additional requirements for explosion-safe (EX) motors	76
Additional requirements for ABB motors of types other than M2_, M3_, M4_, HX_ and AM_	77
Additional requirements for braking applications	77
Additional requirements for ABB high-output and IP23 motors	77
Additional requirements for non-ABB high-output and IP23 motors	77
Additional data for calculating the rise time and the peak line-to-line voltage	78
Selecting the power cables	78
General rules	78
Typical cable sizes	80
Input (supply) cable sizes	80
Output (motor) cable sizes	81
Alternative power cable types	83
Recommended power cable types	83
Power cable types for limited use	83
Not allowed power cable types	83
Motor cable shield	83
Additional US requirements	84
Conduit	84
Armored cable / shielded power cable	84
Planning the braking system	84
Selecting the control cables	84
Shielding	84
Signals in separate cables	85
Signals allowed to be run in the same cable	85
Relay cable type	85
Control panel cable length and type	85
Routing the cables	85
Separate control cable ducts	86
Continuous motor cable shield or enclosure for equipment on the motor cable	86
Implementing thermal overload and short-circuit protection	87
Protecting the drive and input power cable in short-circuits	87
Protecting the motor and motor cable in short-circuits	87
Protecting the drive and the power cables against thermal overload	87
Protecting the motor against thermal overload	87
Protecting the drive against ground faults	87
Residual current device compatibility	88
Implementing the emergency stop function	88
Implementing the Safe torque off function	88
Implementing the Prevention of unexpected start-up function	88
Implementing the functions provided by the FSO-xx safety functions module (option +Q972 or +Q973)	89
Declaration of Conformity	89
Implementing the Power-loss ride-through function	89
Units with main contactor (option +F250)	89



Supplying power for the auxiliary circuits	90
Using power factor compensation capacitors with the drive	90
Implementing a safety switch between the drive and the motor	90
Protecting the contacts of relay outputs	90
Connecting a motor temperature sensor to the drive I/O	92

6. Electrical installation

Contents of this chapter	93
Warnings	93
Checking the insulation of the assembly	93
Drive	93
Input cable	93
Motor and motor cable	94
Custom brake resistor assembly	94
Checking the compatibility with IT (ungrounded) systems	94
Attaching the device stickers to the cabinet door	94
Checking the settings of transformers T21 and T101 and T111	94
T21 and T101 tap settings (400...500 V units)	95
T21 and T101 tap settings (690 V units)	95
T111 tap settings	96
Connecting the control cables	97
Control cable connection procedure	97
Grounding the outer shields of the control cables at the cabinet lead-through ..	97
Routing the control cables inside the cabinet	99
Connecting to the inverter control unit (A41)	99
Connecting a 230/115 V AC auxiliary voltage supply (UPS, option +G307) ...	101
Connecting the emergency stop push buttons (options +Q951, +Q952, +Q963, +Q964, +Q978, +Q979)	101
Wiring the starter for auxiliary motor fan (options +M602...+M610)	101
Wiring the thermistor relay(s) (options +L505 and +2L505)	102
Wiring the Pt100 relays (options +2L506, +3L506, +5L506 and +8L506)	103
Powering the heating and lighting equipment (options +G300, +G301 and +G313)	104
Wiring ground fault monitoring for IT ungrounded systems (option +Q954) ...	105
Connecting the motor cables (units without common motor terminal cubicle or sine output filter)	106
Connection diagram (without option +H366)	106
Connection diagram (with option +H366)	107
Procedure	108
Removing the inverter module(s)	108
Removing and reinstalling the fan carriage of an inverter module	112
Connecting the motor cables	114
Re-installing the fan carriage of an inverter module	116
Re-inserting the inverter module into the cubicle	116
Connecting the motor cables (units with common motor terminal cubicle or sine output filter)	117
Output busbars	117
Connection diagram	117
Procedure	117
Connecting an external brake resistor assembly	118
Connecting the input power cables	119
Connection diagram, 6-pulse units	119
Connection diagram, 12-pulse units	119



Layout of the input cable connection terminals and lead-throughs	120
Connection procedure	120
Connecting a PC	122
Panel bus (Control of several units from one control panel)	123
Installing option modules	124
Mechanical installation of I/O extension, fieldbus adapter and pulse encoder interface modules	124
Mechanical installation of an FSO-xx safety functions module	125
Wiring of optional modules	126

7. Control units of the drive

What this chapter contains	127
General	127
Control unit layout and connections	128
Default I/O diagram of the inverter control unit (A41)	131
External power supply for the control unit (XPOW)	132
DI6 as a PTC sensor input	132
AI1 or AI2 as a Pt100, Pt1000 or KTY84 sensor input	133
DIIL input	133
Drive-to-drive link (XD2D)	133
Safe torque off (XSTO, XSTO OUT)	134
FSO-xx safety functions module connection (X12)	134
SDHC memory card slot	134
Control unit connector data	135

8. Installation checklist

Contents of this chapter	139
Warnings	139
Checklist	139

9. Start-up

Contents of this chapter	141
Start-up procedure	141
Checks/Settings with no voltage connected	142
Powering up the auxiliary circuit of the drive	142
Setting up the supply unit parameters	143
Setting up the drive parameters, and performing the first start	143
Powering up the main circuit of the drive	143
On-load checks	143

10. Fault tracing

Contents of this chapter	145
LEDs	145
Warning and fault messages	145

11. Maintenance

Contents of this chapter	147
Maintenance intervals	147
Preventive maintenance interval table	147



Cabinet	149
Cleaning the interior of the cabinet	149
Cleaning the door air inlets (IP22 and IP42)	149
Cleaning the door air inlets (IP54)	150
Cleaning the outlet (roof) filters (IP54)	150
Replacing the outlet (roof) filters (IP54)	150
Heatsink	151
Power connections and quick connectors	151
Retightening the power connections	151
Fans	152
Replacing the cooling fan in the auxiliary control cubicle	152
Replacing the cooling fan(s) in the incoming cubicle	153
Replacing a roof fan (IP54/UL type 12)	154
Replacing a supply module (D7T) cooling fan	155
Replacing a supply (D8T) or inverter module cooling fan	156
Replacing a frame D7T supply module	157
Replacing a frame D8T supply module	161
Replacing an inverter module	165
Reduced run of the inverter unit	166
Activation of the reduced run function	166
Fuses	169
Replacing the AC fuses	169
Replacing the DC fuses in the inverter module cubicle	171
Replacing the supply module DC fuses	172
Capacitors	173
Reforming the capacitors	173
Control panel	173
Replacing the battery	173
Cleaning	173
Control units	174
BCU control unit types	174
Memory unit	174
Control unit battery	175

12. Technical data

Contents of this chapter	177
Ratings	177
Definitions	179
Derating	179
Ambient temperature derating	179
Altitude derating	179
Switching frequency derating	180
Output frequency derating	180
Frame sizes and power module types	180
Fuses	182
AC fuses	182
DC fuses at inverter module input	184
Supply module internal DC fuses	185
Dimensions and weights	186
Free space requirements	186
Cooling data, noise	186
Sine output filter data	188
Terminal and lead-through data for the power cables	188



Terminal data for the supply and inverter control units	188
Electrical power network specification	189
Motor connection data	189
Control unit connection data	189
Efficiency	190
Protection classes	190
Ambient conditions	190
Materials	191
Applicable standards	192
CE marking	193
Compliance with the European Low Voltage Directive	193
Compliance with the European EMC Directive	193
Compliance with the European Machinery Directive	193
Declaration of Conformity	194
Compliance with EN 61800-3:2004	196
Definitions	196
Category C2	196
Category C3	196
Category C4	197
UL marking	198
UL checklist	198
CSA marking	198
“C-tick” marking	198
EAC (Eurasian Conformity) marking	198
Tightening torques	199
Electrical connections	199
Mechanical connections	199
Insulation supports	199
Cable lugs	199
Disclaimers	200
Generic disclaimer	200
Cyber security disclaimer	200

13. Dimensions

What this chapter contains	201
Cabinet line-up dimensions	202
Dimension tables	203
1×D8T + 2×R8i – 6-pulse connection	203
2×D7T + 2×R8i – 12-pulse connection without option +F259 (grounding switch)	204
2×D7T + 2×R8i – 12-pulse connection with option +F259 (grounding switch)	205
2×D8T + 2×R8i – 6-pulse connection, 400/500 V	205
2×D8T + 2×R8i – 6-pulse connection, 690 V	206
2×D8T + 2×R8i – 12-pulse connection without option +F259 (grounding switch)	206
2×D8T + 2×R8i – 12-pulse connection with option +F259 (grounding switch)	206
2×D8T + 3×R8i – 6-pulse connection; 12-pulse connection without option +F259 (grounding switch)	207
2×D8T + 3×R8i – 12-pulse connection with option +F259 (grounding switch)	207
3×D8T + 3×R8i	207
3×D8T + 4×R8i	207
4×D8T + 3×R8i	208
4×D8T + 4×R8i	208
4×D8T + 5×R8i	209
Weights	210



Dimension drawing examples	211
Frame 2×D7T + 2×R8i (12-pulse)	211
Frame 1×D8T + 2×R8i (IP22)	212
Frame 1×D8T + 2×R8i, IP54 (+B055)	213
Frame 1×D8T + 2×R8i with common motor terminal cubicle (+H359), 1/2	214
Frame 1×D8T + 2×R8i with common motor terminal cubicle (+H359), 2/2	215
Frame 1×D8T + 2×R8i with brake choppers and resistors (+D150 +D151), 1/2	216
Frame 1×D8T + 2×R8i with brake choppers and resistors (+D150 +D151), 2/2	217
Frame 1×D8T + 2×R8i with sine output filter (+E206), 1/2	218
Frame 1×D8T + 2×R8i with sine output filter (+E206), 2/2	219
Frame 2×D8T + 2×R8i (12-pulse) with grounding switch (+F259)	220
Frame 2×D8T + 3×R8i, 1/2	221
Frame 2×D8T + 3×R8i, 2/2	222
Frame 2×D8T + 3×R8i with common motor terminal cubicle (+H359), 1/2	223
Frame 2×D8T + 3×R8i with common motor terminal cubicle (+H359), 2/2	224
Frame 2×D8T + 3×R8i with top entry/top exit, 1/2	225
Frame 2×D8T + 3×R8i with top entry/top exit, 2/2	226
Frame 3×D8T + 4×R8i, 1/2	227
Frame 3×D8T + 4×R8i, 2/2	228
Frame 3×D8T + 4×R8i with common motor terminal cubicle (+H359), 1/2	229
Frame 3×D8T + 4×R8i with common motor terminal cubicle (+H359), 2/2	230
Frame 3×D8T + 4×R8i with top entry/top exit, 1/2	231
Frame 3×D8T + 4×R8i with top entry/top exit, 2/2	232
Frame 4×D8T + 5×R8i (6-pulse) with top entry/exit, UL Listed (+C129), 1/2	233
Frame 4×D8T + 5×R8i (6-pulse) with top entry/exit, UL Listed (+C129), 2/2	234
Location and size of input terminals	235
400 mm, bottom cable entry	235
400 mm, top cable entry	235
600 mm, without main breaker, bottom cable entry (including 12-pulse units with grounding switch)	236
600 mm, without main breaker, top cable entry (including 12-pulse units with grounding switch)	236
600 mm, 12-pulse units without grounding switch, bottom cable entry	237
600 mm, 12-pulse units without grounding switch, top cable entry	237
600 mm, with main breaker, bottom cable entry	238
600 mm, with main breaker, top cable entry	238
1000 mm (UL/CSA), top cable entry	239
1000 mm (UL/CSA), bottom cable entry	240
Location and size of output terminals (units without common motor terminal cubicle)	241
Inverter module cubicle with two modules, bottom cable exit	241
Inverter module cubicle with two modules, top cable exit	241
Inverter module cubicle with three modules, bottom cable exit	242
Inverter module cubicle with three modules, top cable exit	242
Sine filter cubicle (+F206), bottom cable exit	243
Sine filter cubicle (+F206), top cable exit	243
Brake chopper cubicle	244
Location and size of output terminals (units with common motor terminal cubicle)	245
Cubicle width 300 mm, bottom cable exit	245
Cubicle width 300 mm, top cable exit	246
Cubicle width 400 mm, bottom cable exit	247
Cubicle width 400 mm, top cable exit	247
Cubicle width 600 mm, bottom cable exit	248
Cubicle width 600 mm, top cable exit	248



14. The Safe torque off function

What this chapter contains	249
Description	249
Compliance with the European Machinery Directive	250
Wiring	251
Activation switch	251
Cable types and lengths	251
Grounding of protective shields	251
Frame n×R8i inverter unit (internal power supply)	252
Multiple inverter units (internal power supply)	253
Multiple inverter units (external power supply)	254
Operation principle	255
Start-up including acceptance test	255
Authorized person	255
Acceptance test reports	255
Acceptance test procedure	256
Use	257
Maintenance	258
Fault tracing	258
Safety data	259
Abbreviations	259
Declaration of Conformity	260

15. Resistor braking

Contents of this chapter	261
Operating principle	261
Factory-installed brake choppers and resistors	262
Technical data	262
Ratings of chopper/resistor combinations	262
SAFUR resistors	263
Terminals and cable lead-through data of factory-installed chopper/resistor cubicles	263
Planning the braking system	264
Verifying the capacity of the braking equipment	264
Custom resistors	264
Calculating the maximum braking power (Pbr)	265
Selecting and routing the cables of a custom resistor	266
Minimizing electromagnetic interference	266
Maximum cable length	266
EMC compliance of the complete installation	266
Placing custom brake resistors	266
Protecting the system against thermal overload	266
Thermal protection of the resistors	267
Protecting the resistor cable against short-circuits	267
Mechanical installation of custom brake resistors	267
Electrical installation of custom brake resistors	267
Connection diagram	267
Connection procedure	268
Start-up	268



Further information

Product and service inquiries	269
Product training	269
Providing feedback on ABB Drives manuals	269
Document library on the Internet	269



1

Safety instructions



Contents of this chapter

This chapter contains the safety instructions which you must obey when you install and operate the drive and do maintenance on the drive. If you ignore the safety instructions, injury, death or damage can occur.

Use of warnings and notes

Warnings tell you about conditions which can cause injury or death, or damage to the equipment. They also tell you how to prevent the danger. Notes draw attention to a particular condition or fact, or give information on a subject.

The manual uses these warning symbols:



Electricity warning tells about hazards from electricity which can cause injury or death, or damage to the equipment.



General warning tells about conditions, other than those caused by electricity, which can cause injury or death, or damage to the equipment.



Electrostatic sensitive devices warning tells you about the risk of electrostatic discharge which can cause damage to the equipment.

General safety in installation, start-up and maintenance

These instructions are for all personnel that install the drive and do maintenance work on it.



WARNING! Obey these instructions. If you ignore them, injury or death, or damage to the equipment can occur.

- Secure the cabinet to the floor to prevent it from toppling over when you pull out power (inverter/supply modules). The power modules are heavy and have a high center of gravity.



- Wear protective gloves and long sleeves. Some parts have sharp edges.
 - Handle the inverter and supply modules carefully:
 - Use safety shoes with a metal toe cap to avoid foot injury. Use protective gloves.
 - Lift the module with a lifting device only. Use the designated lifting points shown in the drawing below.
 - Do not tilt the module. It will overturn very easily because it is heavy and its center of gravity is high.
 - Make sure that the module does not topple over when you move it on the floor. Whenever possible secure the module with chains. Do not leave the module unattended on a sloping floor.
 - Do not use the module extraction/installation ramp with plinth heights over 50 mm. The ramp supplied with the drive system is designed for a plinth height of 50 mm (the standard plinth height of ABB cabinets).
 - Secure the module extraction/installation ramp carefully.
 - Push the module into the cabinet and pull it from the cabinet carefully preferably with help from another person. Keep a constant pressure with one foot on the base of the module to prevent the module from falling on its back.
-

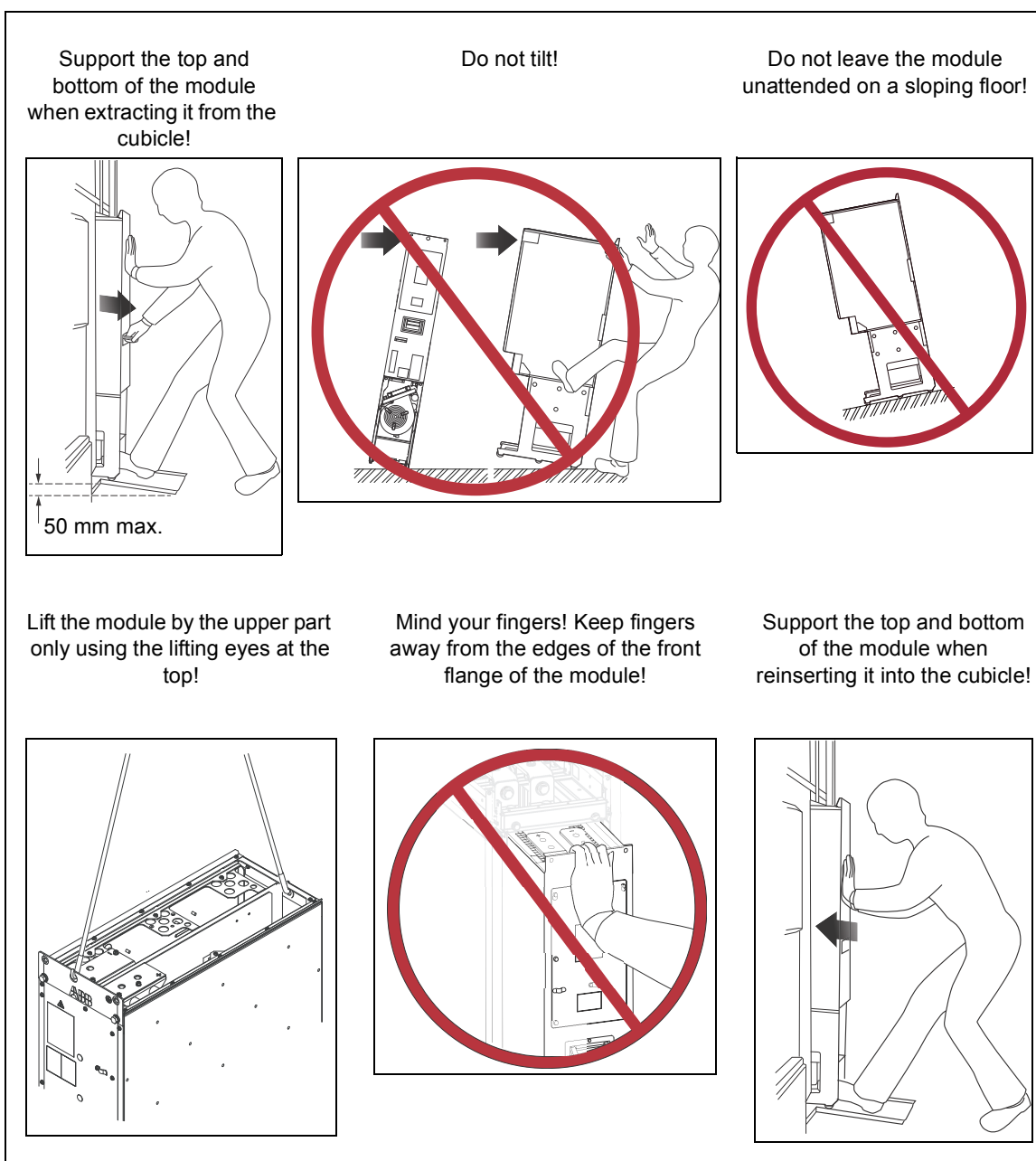

- Beware of hot surfaces. Some parts, such as heatsinks of power semiconductors, and brake resistors, remain hot for a while after disconnection of the electrical supply.
- Keep the drive in its package or protect it otherwise from dust and burr from drilling and grinding until you install it. Protect also the installed drive against dust and burr. Electrically conductive debris inside the drive may cause damage or malfunction.
- Vacuum clean the area around the drive before the start-up to prevent the drive cooling fan from drawing the dust inside the drive.
- Do not cover the air inlet or outlet when the drive is running.
- Make sure that there is sufficient cooling. See section [Examining the installation site](#) (page 57).
- Before you connect voltage to the drive, make sure that the cabinet doors are closed. Keep the doors closed during the operation.

- Before you adjust the drive operation limits, make sure that the motor and all driven equipment can operate throughout the set operation limits.
- Before you activate the automatic fault reset or automatic restart functions of the drive control program, make sure that no dangerous situations can occur. These functions reset the drive automatically and continue operation after a fault or supply break.
- The maximum number of drive power-ups is five in ten minutes. Too frequent power-ups can damage the charging circuit of the DC capacitors.
- Make sure that any safety circuits (for example, emergency stop and Safe torque off) are validated in start-up. See chapter [The Safe torque off function](#) (page 249). For other safety functions, see their separate instructions.

Note:

- If you select an external source for the start command and it is on, the drive will start immediately after fault reset unless you configure the drive for pulse start. See the firmware manual.
 - When the control location is not set to Local, the stop key on the control panel will not stop the drive.
 - Only authorized persons are allowed to repair a malfunctioning drive.
-



Electrical safety in installation, start-up and maintenance

■ Precautions before electrical work

These warnings are for all personnel who do work on the drive, motor cable or motor.



WARNING! Obey these instructions. If you ignore them, injury or death, or damage to the equipment can occur. If you are not a qualified electrician, do not do installation or maintenance work. Go through these steps before you begin any installation or maintenance work.

1. Clearly identify the work location.
 2. Disconnect all possible voltage sources.
 - Open the main switch-disconnector (Q1.1) (or rack out the main breaker, Q1) of the drive.
Note: In some 12-pulse units, there are two separate main switch/disconnectors (Q1.1 and Q1.2), one for each 6-pulse supply line. You must open both.
 - Open the disconnector of the supply transformer as the main switch-disconnector or breaker of the drive does not remove the voltage from the input busbars of the drive.
 - Make sure that reconnection is not possible. Lock the disconnectors to open position and attach a warning notice to them.
 - Disconnect any external power sources (eg. UPS, motor fan supply, or cubicle heater supply) from the control circuits before you do work on the control cables.
 - After you disconnect the drive, always wait 5 minutes to let the intermediate circuit capacitors discharge before you continue.
 3. Protect any other energized parts in the work location against contact.
 4. Take special precautions when close to bare conductors.
 5. Measure that the installation is de-energized.
 - Use a multimeter with an impedance of at least 1 Mohm.
 - Make sure that the voltage between the drive input power terminals (L1, L2, L3) and the grounding (PE) busbar is close to 0 V.
 - Make sure that the voltage between the drive DC busbars (+ and -) and the grounding (PE) busbar is close to 0 V.
 6. Install temporary grounding as required by the local regulations. Close the grounding switch or switches (option +F259, Q9) if present.
 7. Ask the person in control of the electrical installation work for a permit to work.
-



■ Additional instructions and notes



WARNING! Obey these instructions. If you ignore them, injury or death, or damage to the equipment can occur.

- If you are not a qualified electrician, do not do electrical installation or maintenance work.
- Do not install a drive with EMC filter option +E202 on an ungrounded power system or a high resistance-grounded (over 30 ohms) power system.
- Do not connect the drive to a voltage higher than what is stated on the type designation label. If you do, the brake chopper (if present) starts to operate which causes the overheating of the brake resistor. Overvoltage can also cause the motor to rush to its maximum speed.
- We do not recommend that you secure the cabinet by arc welding. If you have to, obey the instructions on page [72](#).
- Do not do insulation or voltage withstand tests on the drive or its modules.

Note:

- The motor cable terminals of the drive are at a dangerous voltage when the input power is on, regardless of whether the motor is running or not.
- The DC bus, brake chopper and brake resistors are at a dangerous voltage.
- External wiring can supply dangerous voltages to the terminals of relay outputs of the control units of the drive.
- The Safe torque off function does not remove the voltage from the main and auxiliary circuits. The function is not effective against deliberate sabotage or misuse.



WARNING! Use a grounding wrist band when you handle printed circuit boards. Do not touch the boards unnecessarily. The boards contain components sensitive to electrostatic discharge.



WARNING! Obey these instructions. If you ignore them, equipment malfunction and damage to fiber optic cables can occur.

- Handle fiber optic cables with care.
 - When you unplug the cables, always hold the connector, not the cable itself.
 - Do not touch the ends of the fibers with bare hands as the ends are extremely sensitive to dirt.
 - Do not bend the fiber optic cables too tightly. The minimum allowed bend radius is 35 mm (1.4").
-

■ Grounding

These instructions are for all personnel who are responsible for the grounding of the drive.



WARNING! Obey these instructions. If you ignore them, injury or death, or equipment malfunction can occur, and electromagnetic interference can increase.

- If you are not a qualified electrician, do not do grounding work.
- Always ground the drive, the motor and adjoining equipment. This is necessary for the personnel safety. Proper grounding also reduces electromagnetic emission and interference.
- Make sure that the conductivity of the grounding conductors is sufficient. See section [Selecting the power cables](#) (page 78). Obey the local regulations.
- Connect the power cable shields to protective earth (PE) of the drive to make sure of personnel safety.
- Make a 360° grounding of the power and control cable shields at the cable entries to suppress electromagnetic disturbances.
- In a multiple-drive installation, connect each drive separately to the protective earth (PE) busbar of the switch board or the transformer.

Note:

- You can use power cable shields as grounding conductors only when their conductivity is sufficient.
 - As the normal touch current of the drive is higher than 3.5 mA AC or 10 mA DC, you must use a fixed protective earth connection. See standard EN 61800-5-1, 4.3.5.5.2.
-



Additional instructions for permanent magnet motor drives

■ Safety in installation, start-up and maintenance

These are additional warnings concerning permanent magnet motor drives. The other safety instructions in this chapter are also valid.



WARNING! Obey these instructions. If you ignore them, injury or death and damage to the equipment can occur.

- Do not do work on the drive when the permanent magnet motor is rotating. A rotating permanent magnet motor energizes the drive including its input power terminals.

Before installation, start-up and maintenance work on the drive:

- Stop the motor.
 - Disconnect the motor from the drive with a safety switch or by other means.
 - If you cannot disconnect the motor, make sure that the motor cannot rotate during work. Make sure that no other system, like hydraulic crawling drives, can rotate the motor directly or through any mechanical connection like felt, nip, rope, etc.
 - Measure that the installation is de-energized.
 - Use a multimeter with an impedance of at least 1 Mohm.
 - Make sure that the voltage between the drive output terminals (U2, V2, W2) and the grounding (PE) busbar is close to 0 V.
 - Make sure that the voltage between the drive input power terminals (L1, L2, L3) and the grounding (PE) busbar is close to 0 V.
 - Make sure that the voltage between the plus and minus busbars of the drive DC link and the grounding (PE) busbar is close to 0 V.
 - Install temporary grounding to the drive output terminals (U2, V2, W2). Connect the output terminals together as well as to the PE.
 - Make sure that the operator cannot run the motor over the rated speed. Motor overspeed causes overvoltage which can damage the capacitors in the intermediate circuit of the drive.
-





Introduction to the manual

Contents of this chapter

This chapter describes the manual. It contains a flowchart of steps in checking the delivery, installing and starting up the drive. The flowchart refers to chapters/sections in this manual and to other manuals.

Target audience

This manual is intended for people who plan the installation, install, start up, use and service the drive. Read the manual before working on the drive. You are expected to know the fundamentals of electricity, wiring, electrical components and electrical schematic symbols.

The manual is written for readers worldwide. Both SI and imperial units are shown.

Contents of the manual

This manual contains the instructions and information for the basic drive configuration. The chapters of the manual are briefly described below.

[Safety instructions](#) gives safety instructions for the installation, start-up, operation and maintenance of the drive.

[Introduction to the manual](#) gives an introduction to this manual.

[Operation principle and hardware description](#) describes the operation principle and construction of the drive.

[Mechanical installation](#) describes how to install the drive mechanically.

[Guidelines for planning the electrical installation](#) contains instructions for the motor and cable selection, protections and cable routing.

Electrical installation gives instructions on wiring the drive.

Control units of the drive contains the default I/O connection diagrams, descriptions of the terminals and technical data for the control units of both the supply and inverter units.

Installation checklist contains a list for checking the mechanical and electrical installation of the drive.

Start-up describes the start-up procedure of the drive.

Fault tracing describes the fault tracing possibilities of the drive.

Maintenance contains preventive maintenance instructions.

Technical data contains the technical specifications of the drive, eg. the ratings, sizes and technical requirements, provisions for fulfilling the requirements for CE and other markings.

Dimensions contains example dimension drawings of the drive.

The Safe torque off function describes the Safe torque off function of the drive and gives instructions on its implementation.

Resistor braking describes selection, protection and wiring of optional brake choppers and resistors. The chapter also contains technical data.

Related manuals

See *List of related manuals* on the inside of the front cover.

Categorization by frame size and option code

Some instructions, technical data and dimension drawings which concern only certain frame sizes are marked with the symbol of the frame size. The frame size indicates the number of power modules that form the supply and inverter units respectively. For example, the marking "2×D8T + 3×R8i" refers to a drive that has a supply unit consisting of two frame D8T diode supply modules and an inverter unit consisting of three frame R8i inverter modules. The frame size is marked on the type designation label (see page 53), and can also be determined from the type code (see table under *Frame sizes and power module types*, page 180).

The instructions, technical data and dimension drawings which only concern certain optional selections are marked with option codes (such as +E205). The options included in the drive can be identified from the option codes visible on the type designation label. The option selections are listed in section *Type designation key* (page 53).

Quick installation, commissioning and operation flowchart

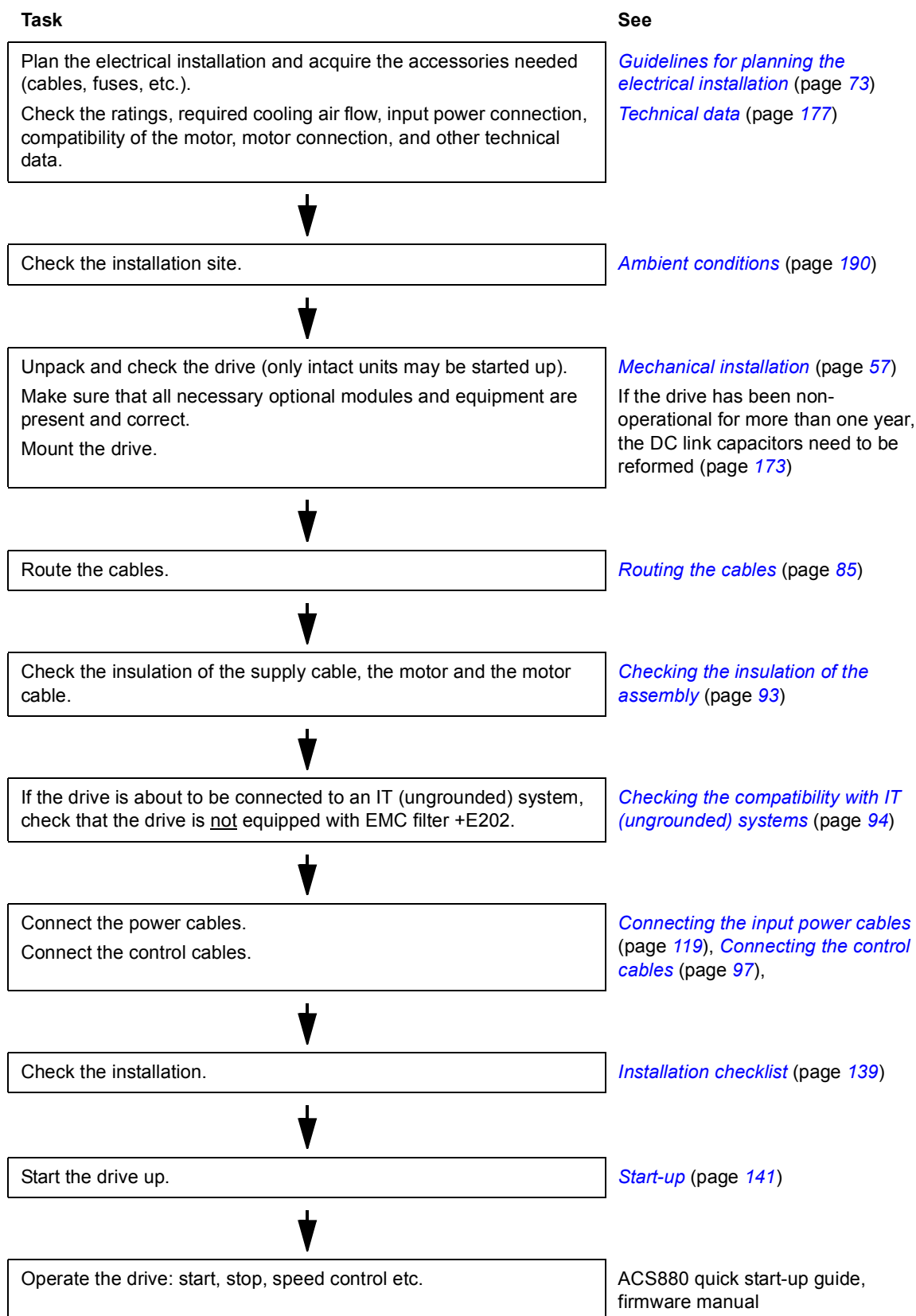

Terms and abbreviations

Term/ Abbreviation	Explanation
BCU	Drive control unit. The drive contains two BCU control units. One controls the supply unit, the other controls the inverter unit. As standard, the external I/O control signals are connected to the control unit, or optional I/O extensions mounted on it.
Drive	Frequency converter for controlling AC motors. The drive consists of the <i>supply unit</i> (aka line-side converter) and the <i>inverter unit</i> (aka motor-side converter) connected together by the DC link. In this manual, the term refers to the ACS880-07 as a whole.
EMC	Electromagnetic compatibility
EMI	Electromagnetic interference
EMT	Electrical metallic tubing
FAIO-01	Optional analog I/O extension module
FCAN-01	Optional FCAN-01 CANopen adapter module
FCNA-01	Optional ControlNet™ adapter module
FDCO-01	Optional DDCS communication module with two pairs of 10 Mbit/s DDCS channels
FDNA-01	Optional DeviceNet™ adapter module
FECA-01	Optional EtherCAT adapter module
FEN-01	Optional TTL incremental encoder interface module
FEN-11	Optional TTL absolute encoder interface module
FEN-21	Optional resolver interface module
FEN-31	Optional HTL incremental encoder interface module
FENA-11	Optional Ethernet adapter module for EtherNet/IP™, Modbus TCP and PROFINET IO protocols
FENA-21	Optional Ethernet adapter module for EtherNet/IP™, Modbus TCP and PROFINET IO protocols, 2-port
FEPL-01	Optional Ethernet POWERLINK adapter module
FIO-01	Optional digital I/O extension module
FIO-11	Optional analog I/O extension module
FLON-01	Optional LonWorks® adapter module
FPBA-01	Optional PROFIBUS DP adapter module
Frame (size)	Relates to the construction type of the component in question. For example, several drive types with different power ratings may have the same basic construction, and a frame size is used in reference to all those drive types. With the ACS880-07 (> 560 kW), the frame size marking of the drive indicates the quantity and frame size of the supply modules, plus the quantity and frame size of the inverter modules, eg. “2×D8T + 3×R8i”. To determine the frame size of a drive type, see the rating tables in chapter Technical data .
FSO-12, FSO-21	Optional functional safety modules
IGBT	Insulated gate bipolar transistor; a voltage-controlled semiconductor type widely used in drives due to their easy controllability and high switching frequency.
Inverter unit	The part of the <i>drive</i> that converts DC to AC for the motor. Consists of inverter modules and their auxiliary components.
I/O	Input/Output
Power module	Supply module or inverter module. See also Frame (size) .
RFI	Radio-frequency interference
SAR	Safe acceleration range

Term/ Abbreviation	Explanation
SBC	Safe brake control
SLS	Safely-limited speed without encoder
SS1	Safe stop 1
SSE	Safe stop emergency
SSM	Safe speed monitor without encoder
STO	Safe torque off
Supply unit	The part of the <i>drive</i> that converts AC to DC. Consists of supply modules and their auxiliary components.

■ Safety data (SIL, PL)

Abbr.	Reference	Description
Cat.	EN ISO 13849-1	Classification of the safety-related parts of a control system in respect of their resistance to faults and their subsequent behavior in the fault condition, and which is achieved by the structural arrangement of the parts, fault detection and/or by their reliability. The categories are: B, 1, 2, 3 and 4.
CCF	EN ISO 13849-1	Common cause failure (%)
DC	EN ISO 13849-1	Diagnostic coverage
FIT	IEC 61508	Failure in time: 1E-9 hours
HFT	IEC 61508	Hardware fault tolerance
MTTF _d	EN ISO 13849-1	Mean time to dangerous failure: (The total number of life units) / (the number of dangerous, undetected failures) during a particular measurement interval under stated conditions
PFD	IEC 61508	Probability of failure on demand
PFH _D	IEC 61508	Probability of dangerous failures per hour
PL	EN ISO 13849-1	Performance level. Levels a...e correspond to SIL
SC	IEC 61508	Systematic capability
SFF	IEC 61508	Safe failure fraction (%)
SIL	IEC 61508	Safety integrity level (1...3)
SILCL	IEC/EN 62061	Maximum SIL (level 1...3) that can be claimed for a safety function or subsystem
SS1	IEC/EN 61800-5-2	Safe stop 1
STO	IEC/EN 61800-5-2	Safe torque off
T1	IEC 61508	Proof test interval. T1 is a parameter used to define the probabilistic failure rate (PFH or PFD) for the safety function or subsystem. Performing a proof test at a maximum interval of T1 is required to keep the SIL capability valid. The same interval must be followed to keep the PL capability (EN ISO 13849) valid. Note that any T1 values given cannot be regarded as a guarantee or warranty. See also section Maintenance (page 258).



3

Operation principle and hardware description

Contents of this chapter

This chapter briefly describes the operation principle and construction of the drive.

Product overview

The ACS880-07 is an air-cooled cabinet-installed drive for controlling asynchronous AC induction motors, permanent magnet synchronous motors and AC induction servomotors.

The drive consists of several cubicles that contain the supply and motor terminals, 1 to 4 diode supply module(s), 2 to 5 inverter modules, and optional equipment. The actual arrangement of the cubicles vary from type to type and the selected options. See chapter [Dimensions](#) for the different line-up variations.

Overview circuit diagram of the drive

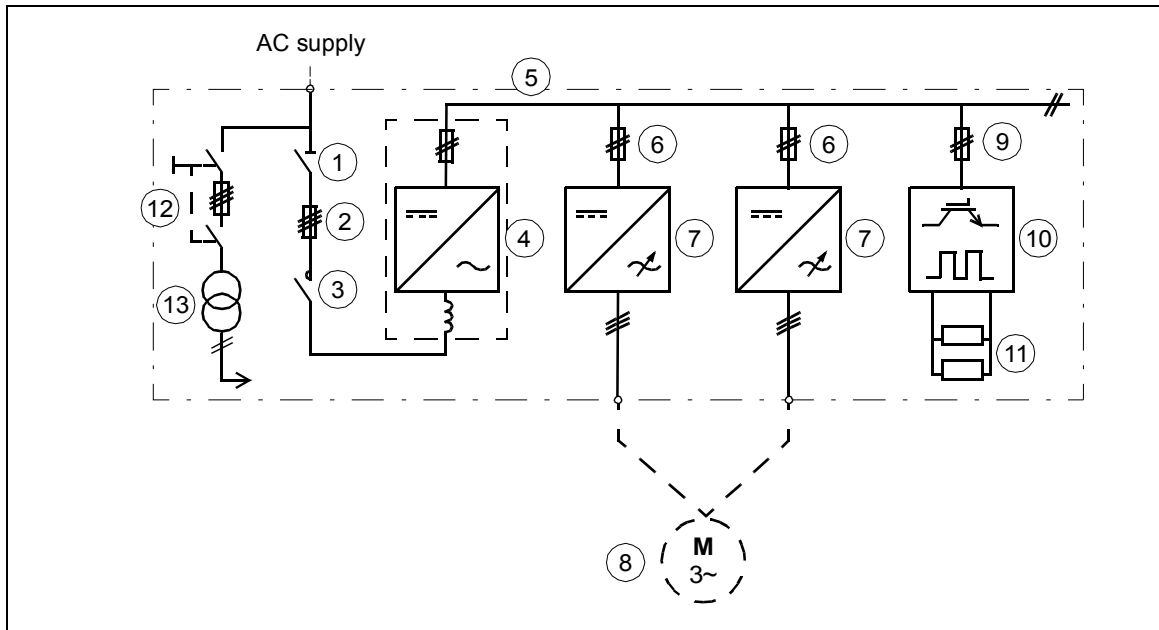

1	*Main switch-disconnector (Q1.1)
2	*AC fuses. <ul style="list-style-type: none"> • Frames 1×D8T + 2×R8i (6-pulse), 2×D7T + 2×R8i (12-pulse), 2×D8T + n×R8i (12-pulse) have AC fuses installed in the incoming cubicle (ICU) only. • Frames 2×D8T + 2×R8i and above (6-pulse) and 4×D8T + n×R8i (12-pulse) have AC fuses installed for each supply module in the supply module cubicle(s). Additional common AC fuses are installed in the incoming cubicle (ICU) if optional main contactor (+F250) is present.
3	*Main contactor (Q2.1). Optional (+F250) with frames 2×D7T + 2×R8i, 2×D8T + 2×R8i and 2×D8T + 3×R8i. 12-pulse units have two contactors (Q2.1 and Q2.2).
*With larger units, an air circuit breaker is either optional (+F255) or standard, replacing items 1...3. Each supply module has dedicated AC fuses installed in the supply module cubicle(s).	
4	Supply module. Converts alternating current and voltage to direct current and voltage. The ACS880-07 has 1...4 supply modules connected in parallel. 12-pulse units have either one or two supply modules per each 6-pulse supply line.
5	DC bus
6	Inverter DC fuses
7	Inverter module. Converts direct current and voltage to alternating current and voltage. The ACS880-07 has 2...5 inverter modules connected in parallel.
8	Motor
9	**Brake chopper DC fuses
10	**Brake chopper. Conducts surplus energy from the intermediate DC circuit of the drive to the brake resistor when necessary. The chopper operates when the DC voltage exceeds a certain maximum limit. The voltage rise is typically caused by deceleration (braking) of a high inertia motor.
11	**Brake resistors
**Brake chopper (+D150) and resistors (+D151) are optionally available for frame sizes 1×D8T + 2×R8i and up. See chapter Resistor braking (page 261).	
12	Auxiliary voltage switch (Q21) with fuses
13	Auxiliary voltage transformers (T21, T101, T111). T21 is standard; T101 and T111 are added whenever required by the options ordered.

12-pulse connection (option +A004)

The figure below illustrates the difference between 6-pulse and 12-pulse AC supply connections. 6-pulse connection is standard. If the drive has an even number of supply modules, you can order it as a 12-pulse version (option +A004).

12-pulse supply connection eliminates the fifth and seventh harmonics, which remarkably reduces the harmonic distortion of the line current and the conducted emissions.

12-pulse connection requires a three-winding transformer, or two separate transformers. There is a 30-degree phase shift between the two 6-pulse supply lines, which are connected to different supply modules through electrically separate switching equipment.

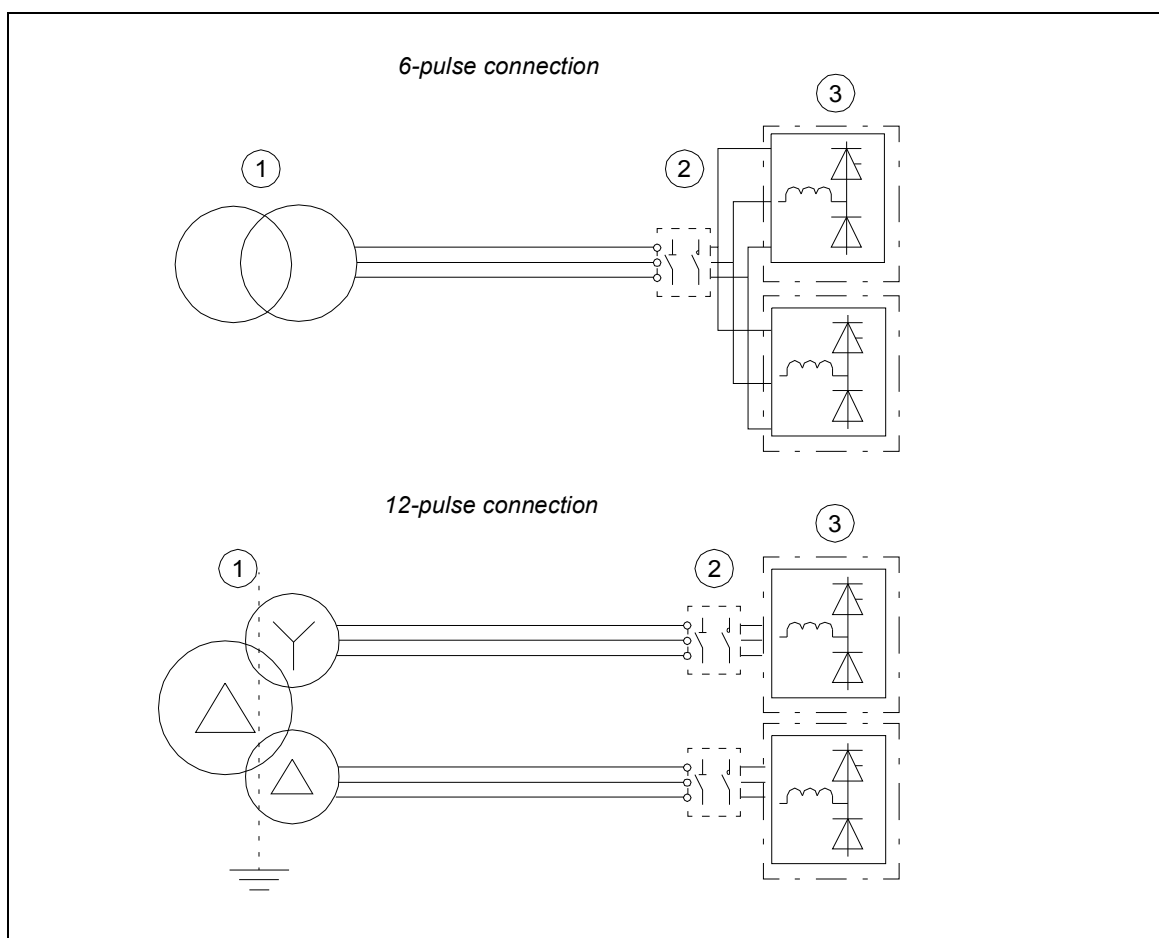

No.	Description
1.	Supply transformer. See section Electrical power network specification (page 189) for transformer requirements.
2.	Switching equipment
3.	Diode supply modules

Cabinet line-up and layout examples

■ Frame 1×D8T + 2×R8i

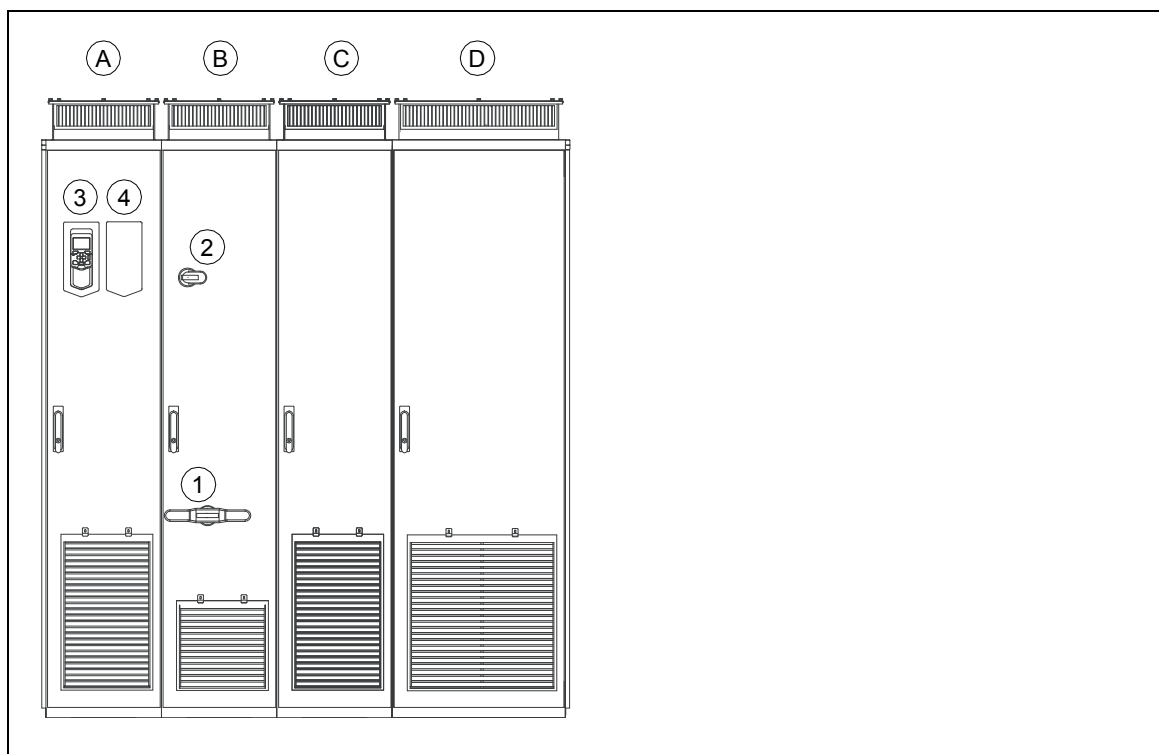

Cabinet line-up example

A	Auxiliary control cubicle (ACU). Contains control electronics and customer I/O connections. See page 40 .
B	Incoming cubicle (ICU). Contains the power input cable terminals and switchgear.
C	Supply module cubicle. Contains the D8T supply module.
D	Inverter module cubicle. Contains two R8i inverter modules. As standard, the motor cables are run from each inverter module to the motor unless the drive is equipped with option +H359 (common motor terminal cubicle), +H366 (common output terminals) or +E206 (sine filters).
1	Main switch-disconnector (Q1.1)
2	Auxiliary voltage switch (Q21)
3	Drive control panel (see page 46)
4	Door switches and lights (see page 44)

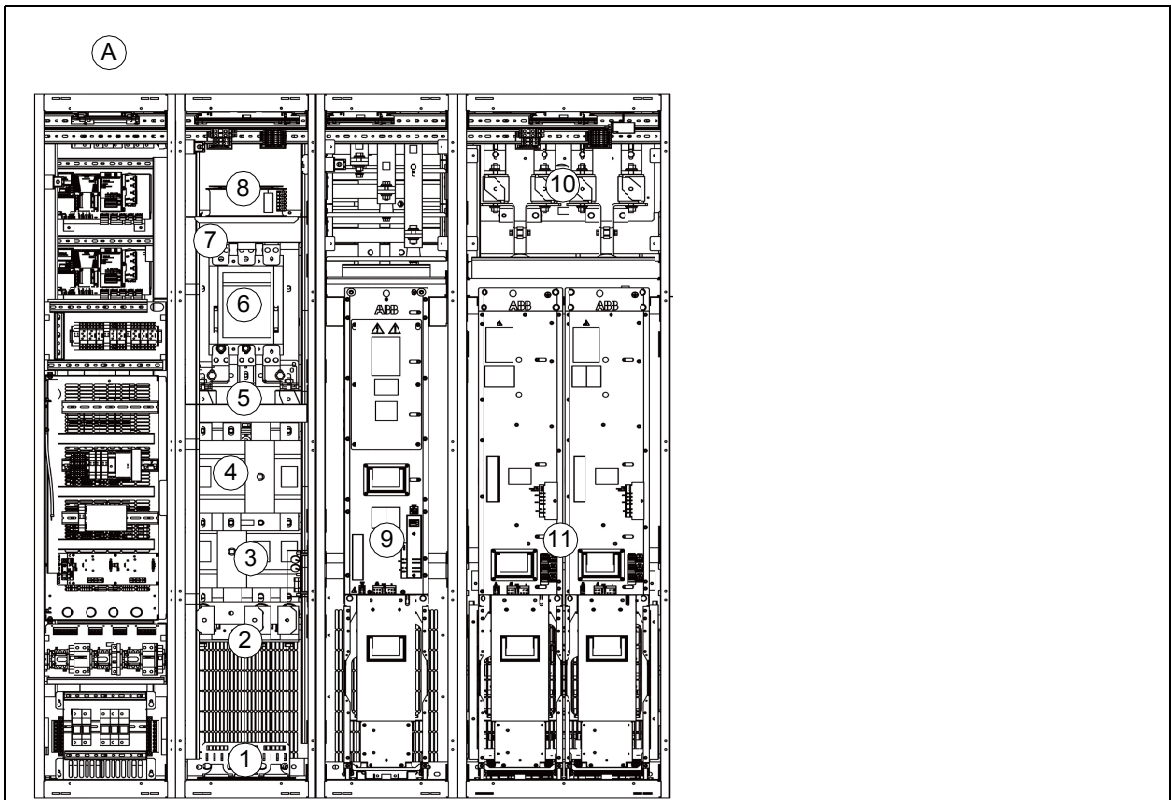

Cabinet layout example

A	Auxiliary control cubicle (ACU). See page 40.
1	Input cable lead-throughs, PE busbar
2	Input terminals
3	Main switch-disconnector (Q1.1)
4	Grounding (earthing) switch (Q9.1) (optional)
5	AC fuses
6	Main contactor (Q2.1) (optional)
7	Auxiliary voltage switch (Q21) with fuses
8	Incoming cubicle cooling fan
9	Supply module
10	Inverter DC fuses
11	Inverter modules. The output terminals are located behind each module. Each module must be individually connected to the motor using separate cables unless the drive is equipped with option +H359 (common motor terminal cubicle), +H366 (common output terminals) or +E206 (sine filters).

■ **Frame 2×D7T + 2×R8i (12-pulse connection, option +A004)**

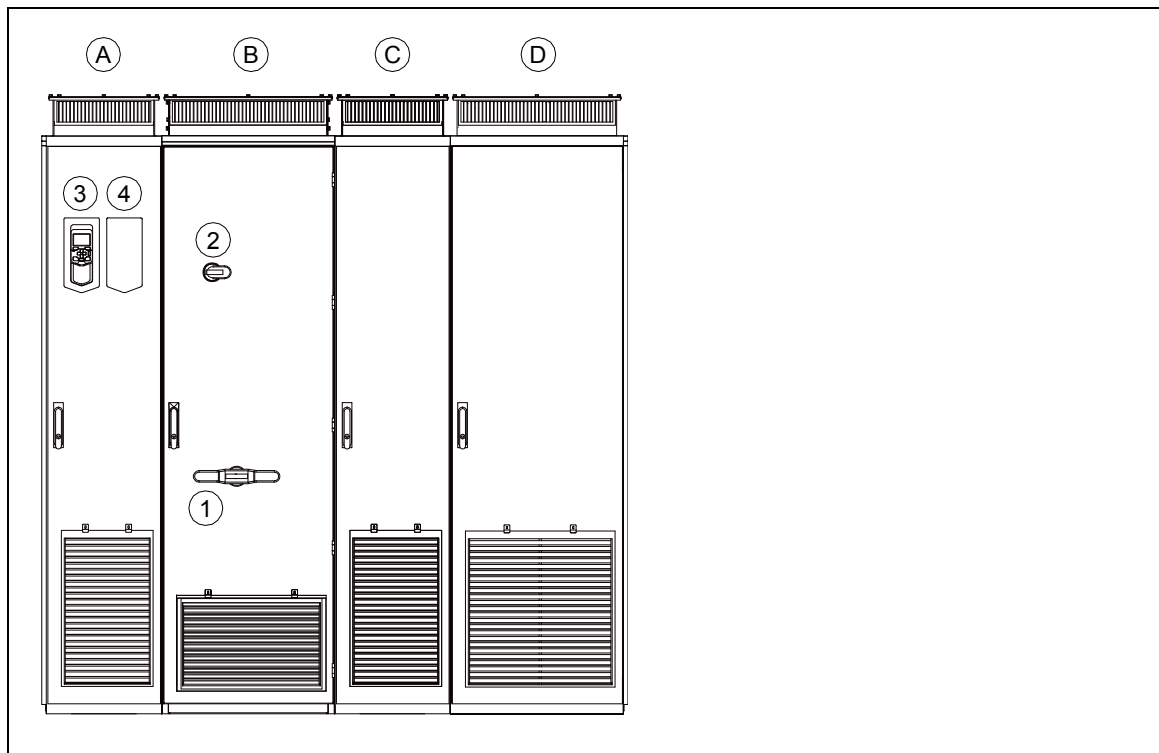

Cabinet line-up example

A	Auxiliary control cubicle (ACU). Contains control electronics and customer I/O connections. See page 40 .
B	Incoming cubicle (ICU). Contains the power input cable terminals and switchgear. With option +F259 (grounding switch), there are two incoming cubicles, one for each 6-pulse supply line.
C	Supply module cubicle. Contains two D7T supply modules, each connected to a different 6-pulse supply line.
D	Inverter module cubicle. Contains two R8i inverter modules. As standard, the motor cables are run from each inverter module to the motor unless the drive is equipped with option +H359 (common motor terminal cubicle), +H366 (common output terminals) or +E206 (sine filters).
1	Main switch-disconnector (Q1.1)
2	Auxiliary voltage switch (Q21)
3	Drive control panel (see page 46)
4	Door switches and lights (see page 44)

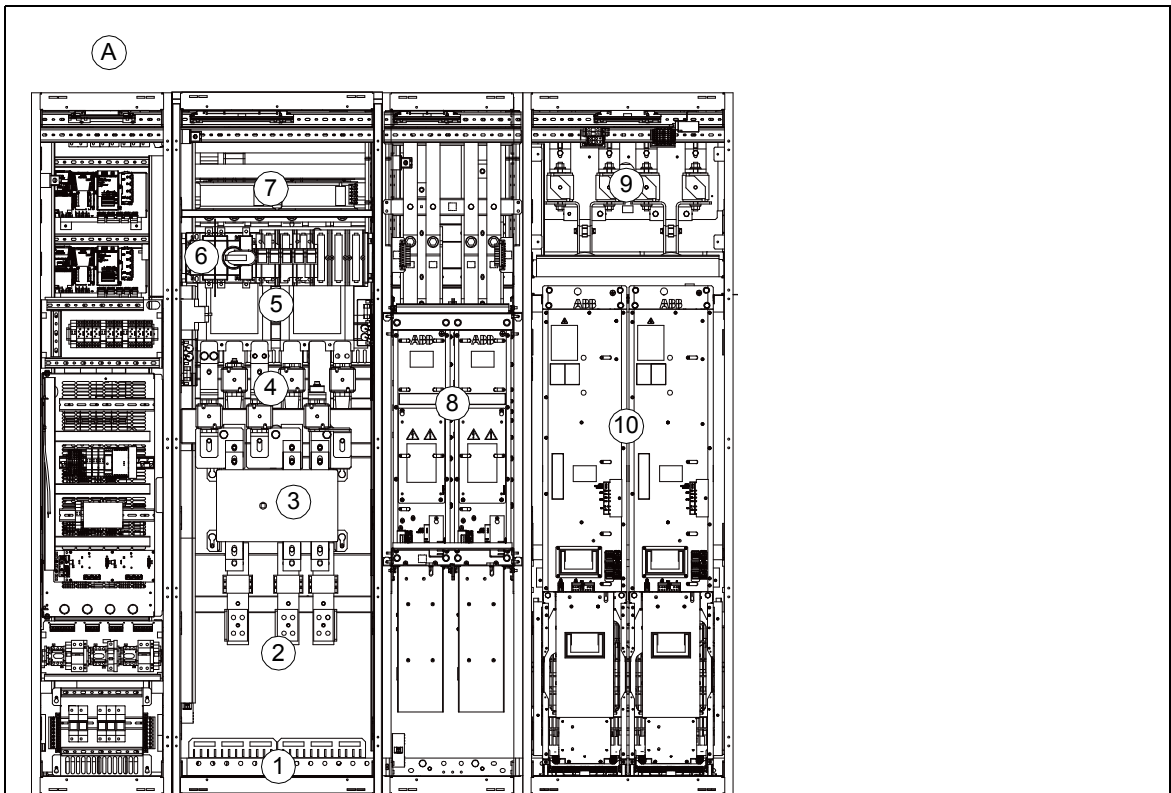

Cabinet layout example

A	Auxiliary control cubicle (ACU). See page 40.
1	Input cable lead-throughs, PE busbar
2	Input terminals
3	Main switch-disconnector (Q1.1)
4	AC fuses
5	Main contactors (Q2.1 and Q2.2) (optional)
6	Auxiliary voltage switch (Q21) with fuses
7	Incoming cubicle cooling fans
8	Supply modules. Each module is connected to a different 6-pulse supply line.
9	Inverter DC fuses
10	Inverter modules. The output terminals are located behind each module. Each module must be individually connected to the motor using separate cables unless the drive is equipped with option +H359 (common motor terminal cubicle), +H366 (common output terminals) or +E206 (sine filters).

■ **Frame 2×D8T + 3×R8i**

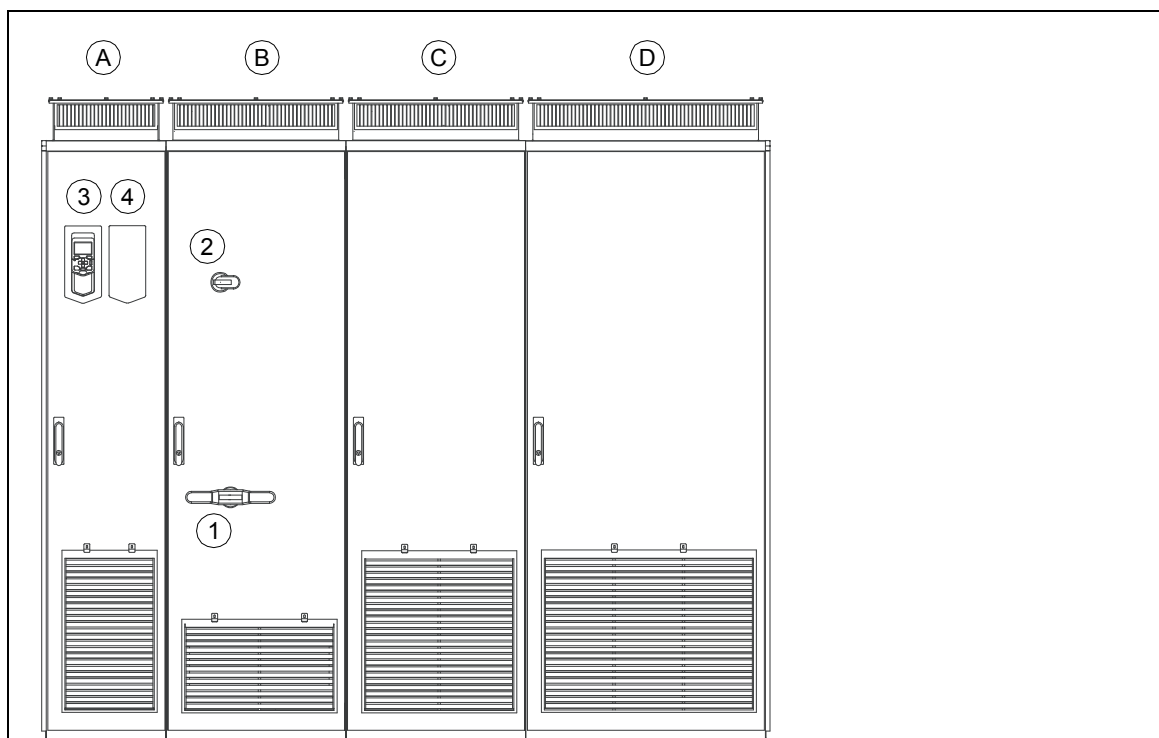

Cabinet line-up example

A	Auxiliary control cubicle (ACU). Contains control electronics and customer I/O connections. See page 40.
B	Incoming cubicle (ICU). Contains the power input cable terminals and switchgear.
C	Supply module cubicle. Contains two D8T supply modules.
D	Inverter module cubicle. Contains three R8i inverter modules. As standard, the motor cables are run from each inverter module to the motor unless the drive is equipped with option +H359 (common motor terminal cubicle) or +H366 (common output terminals).
1	Main switch-disconnector (Q1.1)
2	Auxiliary voltage switch (Q21)
3	Drive control panel (see page 46)
4	Door switches and lights (see page 44)

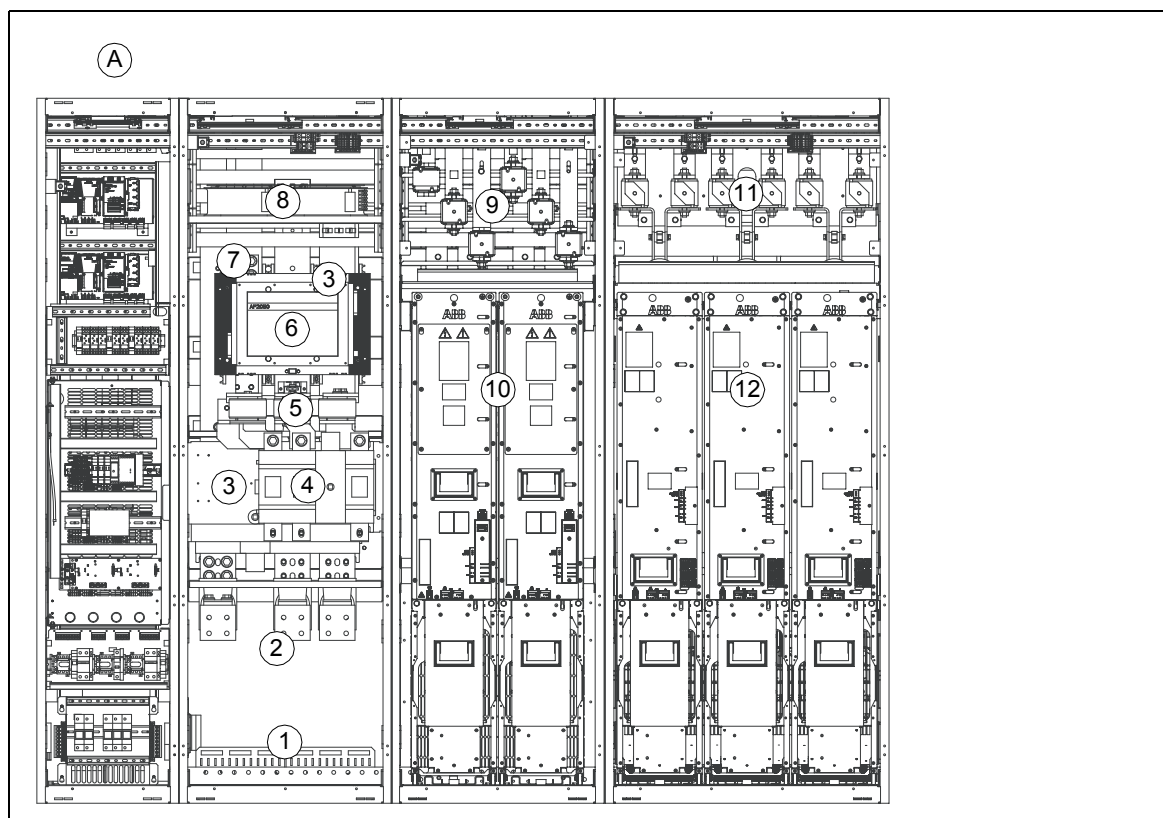

Cabinet layout example

A	Auxiliary control cubicle (ACU). See page 40.
1	Input cable lead-throughs, PE busbar
2	Input terminals
3	Main switch-disconnector (Q1.1)
4	Grounding (earthing) switch (Q9.1) (optional)
5	Common AC fuses (installed with optional main contactor)
6	Main contactor (Q2.1) (optional)
7	Auxiliary voltage switch (Q21) with fuses
8	Incoming cubicle cooling fans
9	Supply module AC fuses
10	Supply modules
11	Inverter DC fuses
12	Inverter modules. The output terminals are located behind each module. Each module must be individually connected to the motor using separate cables unless the drive is equipped with option +H359 (common motor terminal cubicle) or +H366 (common output terminals).

■ **Frame 3×D8T + 4×R8i (with main breaker, option +F255)**

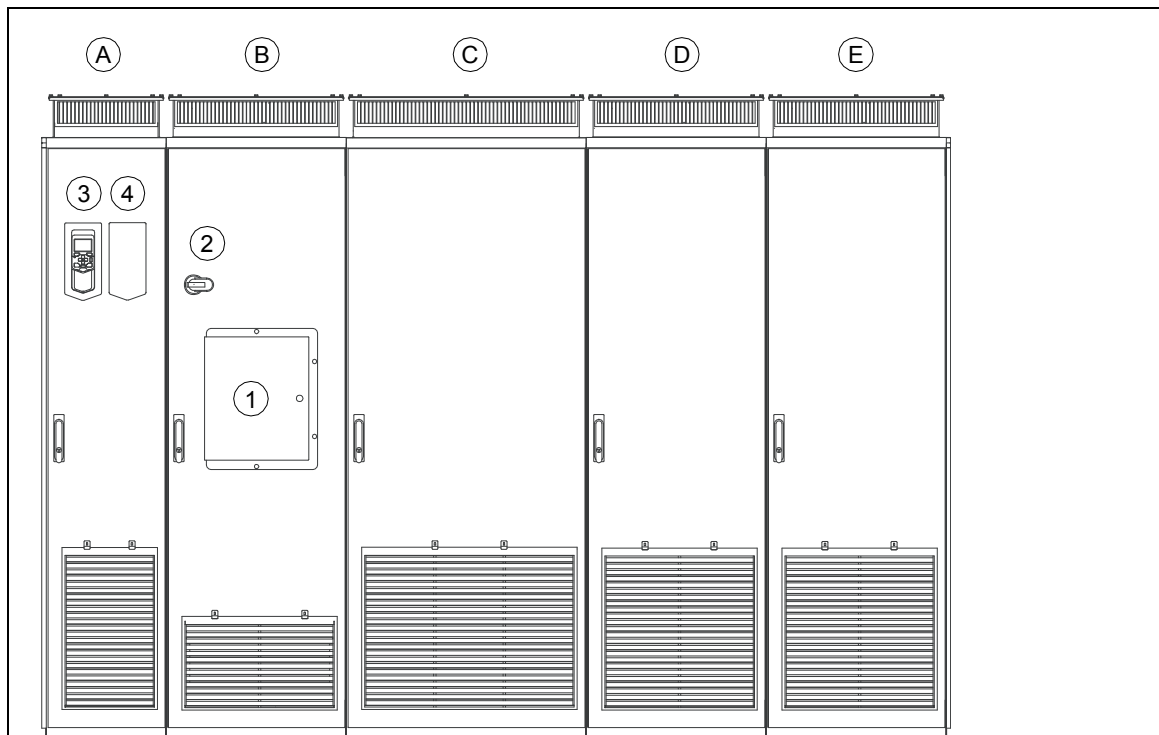

Cabinet line-up example

A	Auxiliary control cubicle (ACU). Contains control electronics and customer I/O connections. See page 40.
B	Incoming cubicle (ICU). Contains the power input cable terminals and switchgear.
C	Supply module cubicle. Contains three D8T supply modules.
D, E	Inverter module cubicles 1 and 2. Each cubicle contains two R8i inverter modules. As standard, the motor cables are run from each inverter module to the motor unless the drive is equipped with option +H359 (common motor terminal cubicle) or +H366 (common output terminals).
1	Main breaker (Q1) (option +F255)
2	Auxiliary voltage switch (Q21)
3	Drive control panel (see page 46)
4	Door switches and lights (see page 44)

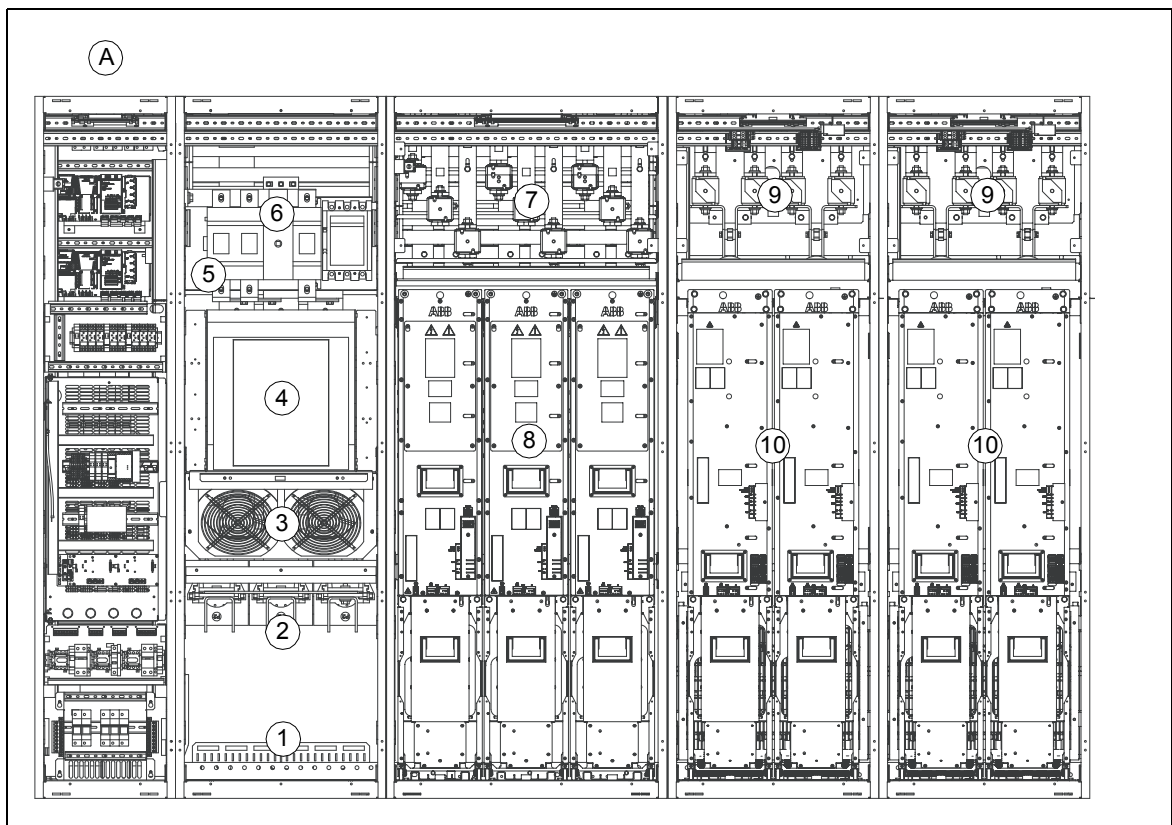

Cabinet layout example

A	Auxiliary control cubicle (ACU). See page 40.
1	Input cable lead-throughs, PE busbar
2	Input terminals
3	Incoming cubicle cooling fans
4	Main breaker (Q1) (option +F255)
5	Auxiliary voltage switch (Q21) with fuses
6	Grounding (earthing) switch (Q9.1) (optional)
7	Supply module AC fuses
8	Supply modules
9	Inverter DC fuses
10	Inverter modules. The output terminals are located behind each module. Each module must be individually connected to the motor using separate cables unless the drive is equipped with option +H359 (common motor terminal cubicle) or +H366 (common output terminals).

Auxiliary control cubicle (ACU) layout

A layout example of the auxiliary control cubicle (ACU) is shown below.

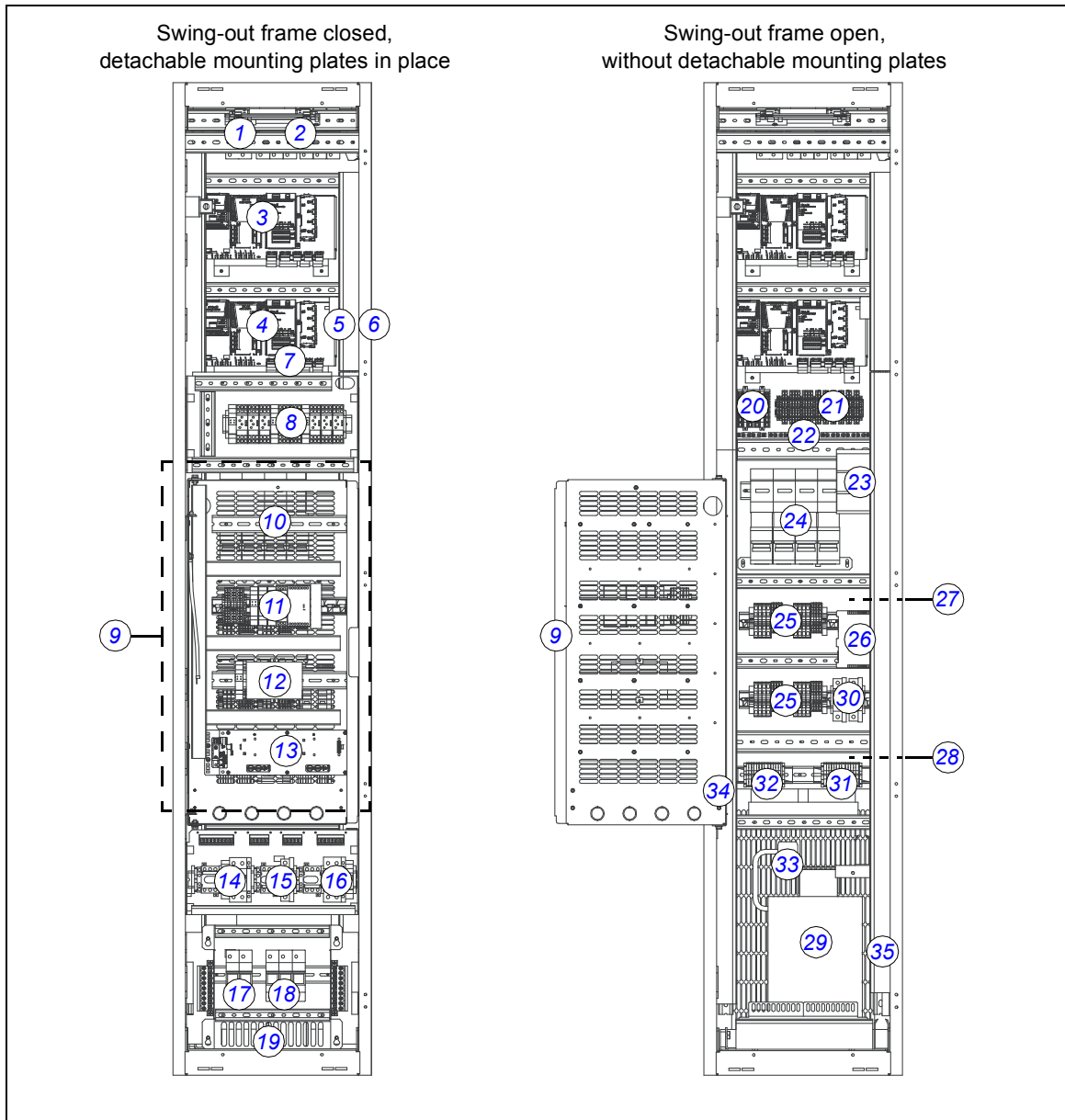

1	Fuse-disconnectors F101. On the primary of transformer T101 (item 27).	19	Lead-through for control cables
2	Fuse-disconnectors (F27) for motor cooling fan outputs (options +M602...610)	20	Terminal block (X68) for FSO-xx safety functions module (option +Q973)
3	Supply control unit (A51). See chapter Control units of the drive (page 127)	21	I/O terminal block (option +L504). The I/O of the inverter control unit is wired to this block.
4	Inverter control unit (A41). Three optional I/O extension, encoder interface, or fieldbus adapter modules can be installed on the unit. Additional modules are installed on item 13. See chapter Control units of the drive (page 127)	22	Grounding/clamping point for control cables
5	Auxiliary voltage circuit breaker F112. On the secondary of transformer T111 (item 29). Mounted on the right-hand inside wall.	23	24 V DC power supply and buffer module

6	Switch (F90) for ground fault monitoring (item 12)	24	Motor fan starters and contactors (options +M602...610)
7	FSO-xx safety functions module (option +Q973 and other options requiring FSO-xx)	25	Terminal blocks (X601) for motor fan connections (options +M602...610)
8	Temperature monitoring relays (options +L505 and +L506). The terminals (X506) are located on the back of the detachable mounting plate.	26	24 V DC power supply for cabinet lighting (option +G301)
9	Swing-out frame	27	Auxiliary voltage transformer T101 (at the back of the cubicle, not visible). Supplies IP54, brake chopper and brake resistor cabinet cooling fans (options +B055, +D150 and +D151).
10	Mounting rail for additional equipment	28	Auxiliary voltage transformer T21 (at the back of the cubicle, not visible). Supplies the control circuitry and the cooling fans in both the incoming unit (ICU) and the auxiliary control unit (ACU).
11	Safety relays (emergency stop, safe torque off)	29	Auxiliary voltage transformer T111. (Customized equipment only.)
12	Ground fault monitoring equipment for ungrounded systems (option +Q954)	30	Auxiliary voltage circuit breakers F22 and F102. On the secondary of transformers T21 (item 28) and T101 (item 27) respectively.
13	FEA-03 extension adapter (option +L515). See item 4.	31	Input voltage setting for auxiliary voltage transformer T101 (item 27)
14	Switch and circuit breaker for externally-supplied motor space heater (option +G313). The terminals (X313) are located on the back of the detachable mounting plate.	32	Input voltage setting for auxiliary voltage transformer T21 (item 28)
15	Switch and circuit breaker for externally-supplied control voltage (option +G307), eg. UPS. The terminals (X307) are located on the back of the detachable mounting plate.	33	Input voltage setting for auxiliary voltage transformer T111 (item 29)
16	Switch and circuit breaker for externally-supplied cabinet lighting and heating (options +G300 and +G301). The terminals (X300) are located on the back of the detachable mounting plate.	34	Terminal blocks <ul style="list-style-type: none"> • X250: indication of main switch-disconnector and contactor status • X951: connection of external emergency stop button • X954: ground fault alarm indication • X957: for connection of Prevention of unexpected start-up switch. Mounted on the left-hand side wall.
17	Fuse-disconnectors F21. On the primary of transformer T21 (item 28). Mounted on a detachable plate.	35	Cubicle heater element (option +G300). Mounted on the right-hand side wall.
18	Fuse-disconnectors F111. On the primary of transformer T111 (item 29). Mounted on a detachable plate.		

Overview of power and control connections

The diagram shows the power connections and control interfaces of the drive.

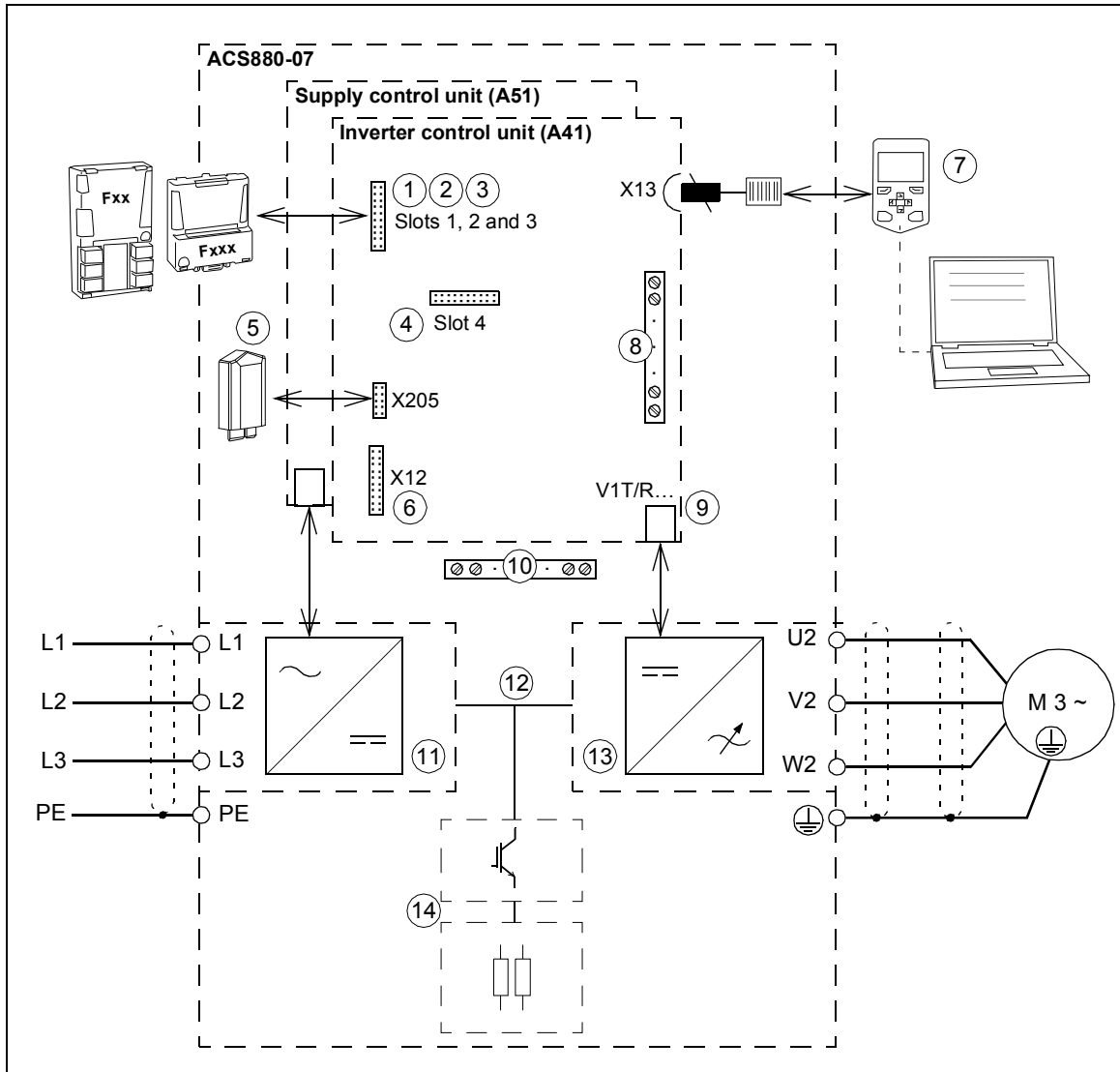

1	Option modules can be inserted into slots 1, 2, 3 and 4 as follows:	
2	Module type	Slots
3	Analog and digital I/O extension modules	1, 2, 3
4	Feedback interface modules	1, 2, 3
	Fieldbus communication modules	1, 2, 3
	RDCO-xx DDCS communication option module (standard equipment). As standard, a fiber optic link connects the supply and inverter control units.	4
	See section Type designation key , page 53	
	Additional modules can be installed on an optional FEA-03 extension adapter connected to the RDCO module on slot 4.	
5	Memory unit (see page 174)	
6	Connection for FSO-xx safety functions module	
7	See section Control panel (page 46)	
8	Terminal blocks on the inverter control unit. See page 99, and Control units of the drive (page 127). These terminals are optionally wired to terminal block X504 in the auxiliary control cabinet of the drive.	

9	Fiber optic link to each inverter module. Similarly, each supply module is connected to the supply control unit by fiber optic cables.
10	Terminal blocks for customer connections installed in the drive cabinet. For the locations, see Auxiliary control cubicle (ACU) layout (page 40). Wiring details are given starting on page 101.
11	Supply unit (consisting of one or more supply modules)
12	DC intermediate link
13	Inverter unit (consisting of two or more inverter modules)
14	Optional brake chopper (+D150) and resistors (+D151)

Door switches and lights



	Label in English	Label in local language	Description				
1	READY	-	Ready light (option +G327)				
2	RUN	-	Run light (option+G328)				
3	FAULT	-	Fault light (option +G329)				
4	RUN/ENBL OFF 	-	Run enable signal switch for the supply unit <table border="1" style="width: 100%;"> <tr> <td>OFF</td> <td>Run enable signal off (starting the supply unit not allowed)</td> </tr> <tr> <td>ON</td> <td>Run enable signal on (starting the supply unit allowed). Close the main contactor if present.</td> </tr> </table>	OFF	Run enable signal off (starting the supply unit not allowed)	ON	Run enable signal on (starting the supply unit allowed). Close the main contactor if present.
OFF	Run enable signal off (starting the supply unit not allowed)						
ON	Run enable signal on (starting the supply unit allowed). Close the main contactor if present.						
5	E-STOP RESET	-	Emergency stop reset push button with options +Q951,+Q952, +Q963 and +Q964				
6	EARTH FAULT	-	Ground (earth) fault light with option +Q954				
7	-	-	Reserved for application-engineered equipment				
8	EMERGENCY STOP	-	Emergency stop push button with options +Q951,+Q952, +Q963 and +Q964				

The layout depends on the options selected.

Main disconnecting device (Q1.1)

Depending on the configuration of the drive, the main disconnecting device of the drive is either a switch-disconnector or a main circuit breaker.

The main disconnecting device switches the main supply to the drive on and off. To disconnect the main supply, turn the switch-disconnector to the 0 (OFF) position, or rack out the main breaker (whichever device is installed).



WARNING! The main disconnecting device does not isolate the input power terminals, AC voltage meters, or the auxiliary voltage circuit from the power line. To isolate the auxiliary voltage circuit, open the auxiliary voltage switch (Q21). To isolate the input power terminals and AC voltage meters, open the main breaker of the supply transformer.

To close the main disconnecting device, auxiliary voltage must be switched on, and the grounding switch (if present) must be open.

Auxiliary voltage switch (Q21)

The auxiliary voltage switch controls the supply to the auxiliary voltage transformers. The transformer feeds the control circuits inside the drive such as cooling fans, relays and measuring equipment. The switch is fitted with fuses.

Grounding (earthing) switch (Q9.x), optional

The grounding switch (Q9.1, option +F259) connects the main AC power bus to the PE busbar. Units with 12-pulse connection (+A004) have two switches (Q9.1 and Q9.2), one for each 6-pulse supply line.

To close the grounding switch, auxiliary voltage must be switched on, and the main disconnecting device must be open.



WARNING! The grounding switch does not ground the input power terminals of the drive or the auxiliary (control) voltage circuits.

Other devices on the door

- Voltmeter (option +G334); comes with a phase selector switch. **Note:** The voltage is measured on the supply side of the main switch or breaker.
 - AC current meter (option +G335) on one phase.
-

■ Control panel

The ACS-AP-I is the user interface of the drive. It provides the essential controls such as Start/Stop/Direction/Reset/Reference, and the parameter settings for the inverter control program.

One control panel can be used to control several drives through a panel link; see section [Panel bus \(Control of several units from one control panel\)](#) (page 123).

The control panel can be removed by pulling it forward from the top edge and reinstalled in reverse order. For the use of the control panel, see *ACS-AP assistant control panel user's manual* (3AUA0000085685 [English]) and the firmware manual.



Control by PC tools

There is a USB connector on the front of the panel that can be used to connect a PC to the drive. When a PC is connected to the control panel, the control panel keypad is disabled.

Descriptions of cabinet options

Note: All options are not available for all drive types, do not coexist with certain other options, or may require additional engineering. Check actual availability with ABB.

■ Degree of protection

Definitions

According to IEC/EN 60529, the degree of protection is indicated by an IP code where the first numeral means protection against ingress of solid foreign objects, and the second numeral protection against ingress of water. The IP codes of the standard cabinet and options covered in this manual are defined below.

IP code	The equipment is protected ...	
	First numeral	Second numeral
IP22	against ingress of solid foreign objects \geq 12.5 mm diameter *	against dripping (15° tilting) water
IP42	against ingress of solid foreign objects \geq 1 mm	against dripping (15° tilting) water
IP54	dust-protected	against splashing water

* meaning for protection of persons: against access to hazardous parts with finger

IP22 (standard)

The degree of protection of the standard drive cabinet is IP22 (UL type 1). The air outlets at the top of the cabinet are covered with a brass grating. The air inlet gratings are covered with plastic gratings. With doors open, the degree of protection of the standard cabinet and all cabinet options is IP20. The live parts inside the cabinet are protected against contact with clear plastic shrouds or metallic gratings.

IP42 (option +B054)

This option provides the degree of protection of IP42 (UL type 1 Filtered). The air inlet gratings are covered with a metallic mesh between the inner metallic grating and the outer plastic grating.

IP54 (option +B055)

This option provides the degree of protection of IP54 (UL type 12). It provides the cabinet air inlets with filter housings containing folded board air filter mats between the inner metallic grating and the outer plastic grating. An additional fan on the cabinet roof is included.

Cooling air intake through bottom of cabinet (option +C128)

See page [70](#).

Channeled air outlet (option +C130)

This option provides a collar for fitting an air outlet duct. The collar is located on the cabinet roof. The option provides the cabinet air inlets with filter housings containing folded board air filter mats between the inner metallic grating and the outer plastic grating.

See also [Air outlet duct on the cabinet roof \(option +C130\)](#) on page [71](#).

■ Marine construction (option +C121)

The option includes the following accessories and features:

- reinforced mechanics
- grab railings
- door flush bolt which allows the door to open 90 degrees and prevents it from slamming close
- self-extinctive materials
- flat bars at base of the cabinet for fastening
- fastening braces at the top of the cabinet.

Required options: Appropriate additional wire marking option (see page 50) according to the requirements of the classification society

■ UL Listed (option +C129)

The option includes factory inspection of the cabinet according to UL 508C and the following accessories and features:

- top entry and exit with US cable conduit entries (plain plate without ready-made holes)
- all components UL Listed/Recognized
- maximum supply voltage 600 V
- main (air circuit) breaker for drive types with 2...4 D8T supply modules.

■ CSA Approved (option +C134)

The option includes the following accessories and features:

- bottom entry and exit with US cable conduit entries (plain plate without ready-made holes)
- all components UL/CSA Listed/Recognized
- maximum supply voltage 600 V
- main (air circuit) breaker with drive types with 2...4 D8T supply modules.

■ Plinth height (options +C164 and +C179)

The standard height of the cabinet plinth is 50 mm. These options specify a plinth height of 100 mm (+C164) or 200 mm (+C179).

■ Seismic design (option +C180)

The option involves seismic capability according to International building code 2012, test procedure ICC-ES AC-156. The installation level must not exceed 25% of the height of the building, and S_{DS} (installation site specific spectral acceleration response) must not exceed 2.0 g.

The option adds the following accessories and features:

- reinforced plinth
- flat bars at base of the cabinet for fastening.

■ Resistor braking (options +D150 and +D151)

See chapter [Resistor braking](#) on page 261.

■ EMC filters (option + E202)

See section [Type designation key](#) on page 53 and sections [Compliance with the European EMC Directive](#) on page 193 and [Compliance with EN 61800-3:2004](#) on page 196.

More information: *Technical Guide No. 3 – EMC Compliant Installation and Configuration for a Power Drive System* (3AFE61348280 [English])

■ Cabinet heater with external supply (option +G300)

The option contains:

- heating elements in the cubicles and supply/inverter modules
- load switch for providing electrical isolation during service
- miniature circuit breaker for overcurrent protection
- terminal block for external power supply.

The heater prevents humidity condensation inside the cabinet when the drive is not running. The power output of the semiconductor-type heating elements depends on the environmental temperature. The customer must switch the heating off when it is not needed by cutting the supply voltage off.

The customer must supply the heater from an external 110...240 V AC power source.

See also

- [Powering the heating and lighting equipment \(options +G300, +G301 and +G313\)](#)
- circuit diagrams delivered with drive for the actual wiring.

■ Terminals for external control voltage (option +G307)

The option provides terminals for connecting external uninterruptible control voltage to the control unit and control devices when the drive is not powered.

See also

- [Supplying power for the auxiliary circuits](#) on page 90
- [Connecting a 230/115 V AC auxiliary voltage supply \(UPS, option +G307\)](#) on page 101
- circuit diagrams delivered with drive for the actual wiring.

■ Output for motor space heater (option +G313)

The option contains:

- load switch for providing electrical isolation during service
- miniature circuit breaker for overcurrent protection
- terminal block for external supply and heating element(s) connection



The heater is off when the drive is running. The customer controls the heating elements in the motor windings on and off with the external supply. The power and voltage of the motor heater depend on the motor.

See also

- [Supplying power for the auxiliary circuits](#) on page 90
 - [Powering the heating and lighting equipment \(options +G300, +G301 and +G313\)](#) on page 104
 - circuit diagrams delivered with drive for the actual wiring.
-

Additional wire markings (options +G340 and +G342)

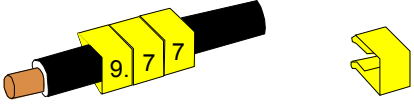
As standard, drive input and output terminals, plug-in connectors, fiber optic connectors and ribbon cables are marked. The wire marking options are described below.

Additional markings	
+G340	<p>Equipment pin numbers are marked with snap-on markers on wires between modules and on wires connected to equipment, terminal blocks and detachable screw terminals. Plug-in connector identifications are marked on labels near the connectors. The label holders are attached around conductor bundles. Main circuit conductors are marked with white tape or printing.</p> 
+G342	<p>Equipment identifications and terminal block pin numbers and remote addresses are marked with tubing or rings on wires between modules, and on wires connected to equipment, terminal blocks and detachable screw terminals. Plug-in connector identifications are marked on labels attached around the conductor bundles near the connectors. Main circuit conductors are marked with white tape or printing.</p> <p>Note: Even wires with equipment and pin identifiers ready printed on the wire insulation are marked with rings or tubing. Remote end addresses are not marked on wire ends that are connected to plug-in connectors. Short and obvious connections are marked with printing only.</p> 

Cable conduit entry (option +H358)

The option provides US/UK conduit plates (plain 3 mm thick steel plates without any ready-made holes). US/UK conduit plates are provided as standard with options +C129 and +C134 instead of the normal cable entries.

Common motor terminal cubicle (option +H359)

As standard, each inverter module must be individually cabled to the motor. This option provides an additional cubicle containing a single set of terminals for the motor cables.

The width of the cubicle and the size of the terminals within depend on the power rating of the drive. See chapter [Dimensions](#) (page 201).

Note that this option is not available with option +E206 (sine filters), In this case, the motor cables are connected to the sine filter cubicle.

Common output terminal (option +H366)

As standard, each inverter module must be individually cabled to the motor. This option adds bridging that connects the outputs of multiple (in practice, two or three) inverter modules mounted in the same cubicle. The bridging balances the motor current between the modules, which allows more cabling options. For example, it is possible to use a number of cables that could not otherwise be evenly distributed between the inverter modules.



WARNING! The bridging can carry the nominal output of one inverter module. In case of three parallel modules, ensure that the load capacity of the bridging is not exceeded. For example, if the cabling connects to the output busbars at one

module only, use the module in the middle.

Note: The +H366 option only interconnects the outputs of inverter modules within the same cubicle, not modules installed in different cubicles. Therefore, when the drive has more than three inverter modules, make sure that the load is distributed evenly between the modules:

- In case of two inverter cubicles of two modules, connect the same number of cables to each cubicle.
- In case of one inverter cubicle with three modules and another with two, each cubicle requires a number of cables proportional to the number of modules within. For example, connect three out of five (or six out of ten, etc.) cables to the cubicle with three modules, the remaining two out of five (four out of ten) cables to the cubicle with two modules.

■ Additional terminal block X504 (option +L504)

The standard terminal blocks of the drive control unit are wired to the additional terminal block at the factory for customer control wiring. The terminals are spring loaded.

Cables accepted by the terminals:

- solid wire 0.08 to 4 mm²
- stranded wire with ferrule 0.14 to 2.5 mm²
- stranded wire without ferrule 0.08 to 2.5 mm² (28 to 12 AWG).

Stripping length: 10 mm.

Note: The optional modules inserted in the slots of the control unit (or optional FEA-03 extension adapter) are not wired to the additional terminal block. The customer must connect the optional module control wires directly to the modules.

■ Thermistor relays (options +L505, +2L505)

The thermistor relay is used for the overtemperature supervision of motors equipped with PTC thermistors. When the motor temperature rises to the thermistor wake-up level, the thermistor resistance increases sharply. The relay detects the change and indicates motor overtemperature through its auxiliary contacts.

Option +L505 provides a thermistor relay and an auxiliary relay and connection terminals for one measuring circuit (one PTC thermistor) and for one normally open contact. The relay can be reset locally or from a remote reset switch wired to the relay.

Option +2L505 provides two thermistor relays and auxiliary relays and connection terminals for two measuring circuit (one PTC thermistor in each) and for two normally open contacts. The relays can be reset locally or from a remote reset switch wired to the relay.

The customer connects PTC sensors to the thermistor relay, and the terminals of the auxiliary relay of the normally open contact, for example, to

- main breaker control circuit of the drive for opening the breaker in case of motor overtemperature or
 - appropriate digital input of the drive for tripping the drive and generating a fault message in case of motor overtemperature or
 - customer control circuit.
-

See also

- firmware manual for parameter settings
- [Wiring the thermistor relay\(s\) \(options +L505 and +2L505\)](#) on page 102
- circuit diagrams delivered with the drive for the actual wiring.

■ Pt100 relays (options +2L506, +3L506, +5L506, +8L506)

What the option contains

The standard Pt100 relay option includes two (+2L506), three (+3L506), five (+5L506) or eight (+8L506) Pt100 temperature monitoring relays and an auxiliary relay wired to a terminal block. Other numbers of Pt100 relays must be ordered as application engineered.

Description

A Pt100 relay is used for overtemperature supervision of motors equipped with Pt100 sensors. For example, three sensors measure the temperature of the motor windings and two sensors the temperature of the bearings. The sensor resistance increases linearly as the temperature rises. The relay releases at an adjustable wake-up level and indicates motor overtemperature through its change-over contact.

The relay provides connection terminals for one Pt100 temperature sensor and terminals of one normally open and one normally closed contact.

The customer connects Pt100 sensors to the Pt100 relays (one sensor per relay) and the auxiliary relays of the normally open contacts of the Pt100 relays, for example, to

- main breaker control circuit of the drive for opening the breaker in case of motor overtemperature or
- appropriate digital input of the drive for tripping the drive and generating a fault message in case of motor overtemperature or
- customer control circuit.

See also

- firmware manual for parameter settings
 - [Wiring the Pt100 relays \(options +2L506, +3L506, +5L506 and +8L506\)](#) on page 103
 - Pt100 relay alarm and trip limit setting instructions on page 142
 - circuit diagrams delivered with the drive for the actual wiring.
-

Type designation label

The type designation label includes ratings, appropriate markings, a type designation and a serial number, which allow identification of each unit. A sample label is shown below.

Quote the complete type designation and serial number when contacting technical support.

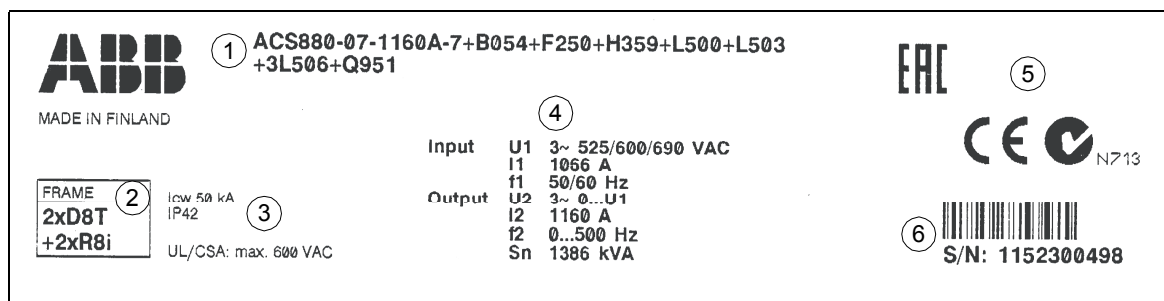

No.	Description
1	Type designation (see section Type designation key below)
2	Frame size
3	Short-time withstand current rating (see page 189); degree of protection; UL/CSA specifications
4	Ratings
5	Valid markings
6	Serial number. The first digit of the serial number refers to the manufacturing plant. The next four digits refer to the unit's manufacturing year and week, respectively. The remaining digits complete the serial number so that there are no two units with the same number.

Type designation key

The type designation contains information on the specifications and configuration of the drive. The first digits from left express the basic configuration (eg, ACS880-07-1580A-5). The optional selections are given thereafter, separated by plus signs, eg, +E202. The main selections are described below. Not all selections are available for all types. For more information, refer to *ACS880 Ordering Information* (3AXD10000052815, available on request).

CODE	DESCRIPTION
Basic codes	
ACS880	Product series
07	When no options are selected: cabinet-installed drive, IP22 (UL Type 1), main switch-disconnector (and contactor) or breaker, aR fuses, ACS-AP-I assistant control panel, EMC filter (category 3, 2nd Environment), du/dt filters, common mode filtering, ACS880 primary control program, Safe torque off function, coated circuit boards, bottom entry and exit of cables with lead-through-type entries, multilingual door device label sticker, USB memory stick containing circuit diagrams, dimension drawings and manuals.
Size	
xxxxx	Refer to the rating tables (page 177)
Voltage range	
3	380...415 V AC. This is indicated in the type designation label as typical input voltage level (3~ 400 V AC)
5	380...500 V AC. This is indicated in the type designation label as typical input voltage levels (3~ 400/480/500 V AC)
7	525...690 V AC. This is indicated in the type designation label as typical input voltage levels (3~ 525/600/690 V AC)

CODE	DESCRIPTION
Option codes (plus codes)	
Supply connection	
A004	12-pulse supply connection
Degree of protection	
B054	IP42 (UL Type 1)
B055	IP54 (UL Type 12)
Construction	
C121	Marine construction (page 48)
C128	Air inlet through bottom of cabinet (page 70)
C129	UL Listed (page 48)
C130	Channeled air outlet (page 47)
C134	CSA Approved (page 48)
C164	Plinth height 100 mm (page 48)
C179	Plinth height 200 mm (page 48)
C180	Seismic design (page 48)
C199	Empty 400 mm wide cubicle on left
C200	Empty 600 mm wide cubicle on left
C201	Empty 800 mm wide cubicle on left
Resistor braking	
D150	Brake choppers (page 48)
D151	Brake resistors (page 48)
Filters	
E202	EMC filter for first environment TN (grounded) system, category C2 (page 49)
E206	Sine output filter
Line options	
F250	Line contactor
F255	Air circuit breaker
F259	Grounding (earthing) switch
Cabinet equipment	
G300	Cabinet and module heating elements (external supply) (page 49)
G301	Cabinet lighting
G307	Terminals for connecting external control voltage (230 V AC or 115 V AC, eg. UPS) (page 49)
G313	Output for motor heater (external supply)
G317	Supply connection by busbars
G327	Ready light, white
G328	Run light, green
G329	Fault light, red
G330	Halogen-free wiring and materials
G334	V-meter with selector switch
G335	A-meter in one phase
G340	Additional wire markings (page 50)
G342	
Cabling	
H350	Bottom entry
H351	Top entry

CODE	DESCRIPTION
H352	Bottom exit
H353	Top exit
H358	Cable conduit entry (US/UK) (page 50)
H359	Common motor terminal cubicle (page 50)
H366	Common output terminals (for inverter modules mounted in the same cubicle) (page 50)
Fieldbus adapters	
K451	FDNA-01 DeviceNet™ adapter module
K454	FPBA-01 PROFIBUS DP adapter module
K457	FCAN-01 CANopen adapter module
K458	FSCA-01 RS-485 adapter module
K462	FCNA-01 ControlNet™ adapter module
K469	FECA-01 EtherCat adapter module
K470	FEPL-02 EtherPOWERLINK adapter module
K473	FENA-11 Ethernet adapter module for EtherNet/IP™, Modbus TCP and PROFINET IO protocols
K475	FENA-21 Ethernet adapter module for EtherNet/IP™, Modbus TCP and PROFINET IO protocols, 2-port
I/O extensions and feedback interfaces	
L500	FIO-11 analog I/O extension module
L501	FIO-01 digital I/O extension module
L502	FEN-31 HTL incremental encoder interface module
L503	FDCO-01 optical DDCS communication adapter module
L504	Additional I/O terminal block (page 51)
L505	Thermistor relay (1 or 2 pcs) (page 51)
L506	Pt100 relay (2, 3, 5 or 8 pcs) (page 52)
L508	FDCO-02 optical DDCS communication adapter module
L513	ATEX-certified thermal protection with PTC relays (1 or 2 pcs)
L514	ATEX-certified thermal protection with Pt100 relays (3, 5 or 8 pcs)
L515	FEA-03 I/O extension adapter
L516	FEN-21 resolver interface module
L517	FEN-01 TTL incremental encoder interface module
L518	FEN-11 TTL absolute encoder interface module
L521	FSE-31 pulse encoder interface module
L525	FAIO-01 analog I/O extension module
L526	FDIO-01 digital I/O extension module
Starter for auxiliary motor fan	
M602	Trip limit setting range: 2.5 ... 4 A
M603	Trip limit setting range: 4 ... 6.3 A
M604	Trip limit setting range: 6.3 ... 10 A
M605	Trip limit setting range: 10...16 A
M606	Trip limit setting range: 16...20 A
M610	Trip limit setting range: 20...25 A
Control program	
N8010	IEC 61131-3 application programmability
Specialties	
P902	Customized
P904	Extended warranty

CODE	DESCRIPTION
P912	Seaworthy packaging
P913	Special color
P929	Container packaging
Safety functions	
Q950	Prevention of unexpected start-up with FSO-xx safety functions module, by activating the Safe torque off function
Q951	Emergency stop (category 0) with safety relays, by opening the main breaker/contactator
Q952	Emergency stop (category 1) with safety relays, by opening the main breaker/contactator
Q954	Ground fault monitoring for IT (ungrounded) systems
Q957	Prevention of unexpected start-up with safety relays, by activating the Safe torque off function
Q963	Emergency stop (category 0) with safety relays, by activating the Safe torque off function
Q964	Emergency stop (category 1) with safety relays, by activating the Safe torque off function
Q971	ATEX-certified safe disconnection function
Q972	FSO-21 safety functions module
Q973	FSO-12 safety functions module
Q978	Emergency stop (configurable for category 0 or 1) with FSO-xx safety functions module, by opening the main breaker/contactator
Q979	Emergency stop (configurable for category 0 or 1) with FSO-xx safety functions module, by activating the Safe torque off function
Q982	PROFIsafe with FSO-xx safety functions module and FENA-21 Ethernet adapter module
Full set of printed manuals in the selected language	
Note: The delivery may include manuals in English if the requested language is not available.	
R700	English
R701	German
R702	Italian
R703	Dutch
R704	Danish
R705	Swedish
R706	Finnish
R707	French
R708	Spanish
R709	Portuguese
R711	Russian

4

Mechanical installation

Contents of this chapter

This chapter describes the mechanical installation procedure of the drive.



Examining the installation site

Examine the installation site:

- The installation site is sufficiently ventilated or cooled to transfer away the drive losses. ¹⁾
- The ambient conditions of the drive meet the specifications. ¹⁾
- The wall behind the unit is of non-flammable material.
- There is enough free space above the drive to enable cooling air flow, service and maintenance.
- The floor that the unit is installed on is of non-flammable material, as smooth as possible, and strong enough to support the weight of the unit. Check the floor flatness with a spirit level. The maximum allowed deviation from the surface level is 5 mm in every 3 meters. Level the installation site, if necessary, as the cabinet is not equipped with adjustable feet.

¹⁾ The heat losses and ambient conditions are specified in chapter [Technical data](#).

Note: The module extraction/installation ramp included with the drive is only suitable for a height difference of 50 mm maximum (ie. the standard plinth height of the drive).

Necessary tools

The tools required for moving the unit to its final position, fastening it to the floor and wall and tightening the connections are listed below:

- crane, fork-lift or pallet truck (check load capacity!), slate/spud bar, jack and rollers
- Pozidriv and Torx screwdrivers
- torque wrench
- set of wrenches or sockets.

Checking the delivery

The drive delivery contains:

- drive cabinet line-up
- optional modules (if ordered) installed onto the control unit at the factory
- appropriate drive and optional module manuals
- delivery documents.

Check that there are no signs of damage. Before attempting installation and operation, check the information on the type designation labels of the drive to verify that the delivery is of the correct type. See section [Type designation key](#) on page 53.



Moving and unpacking the drive

Move the drive in its original packaging to the installation site as shown below to avoid damaging the cabinet surfaces and door devices. When you are using a pallet truck, check its load capacity before you move the drive.

The drive cabinet is to be moved in the upright position.

The center of gravity of the cabinet is high. Be therefore careful when moving the unit. Avoid tilting.

■ Moving the drive in its packaging

Lifting the crate with a forklift

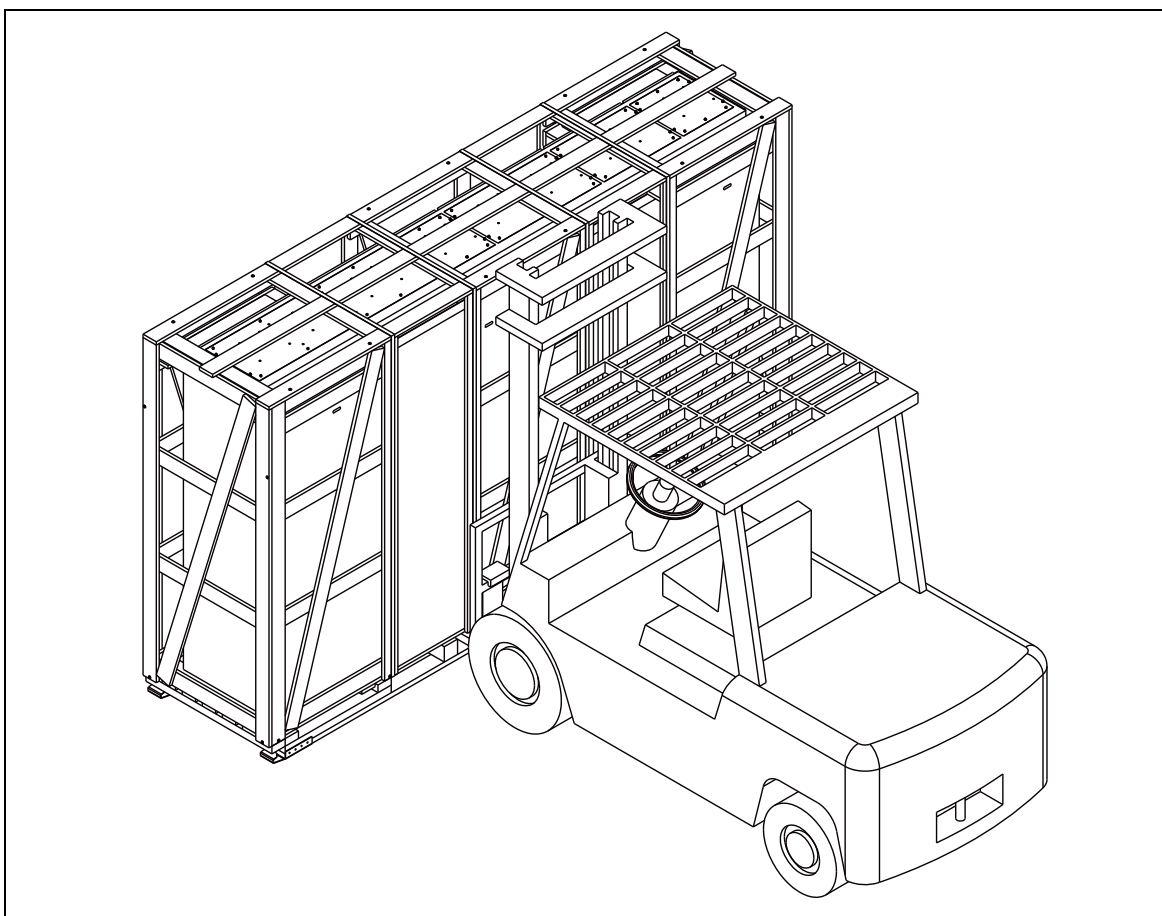

Lifting the crate with a crane

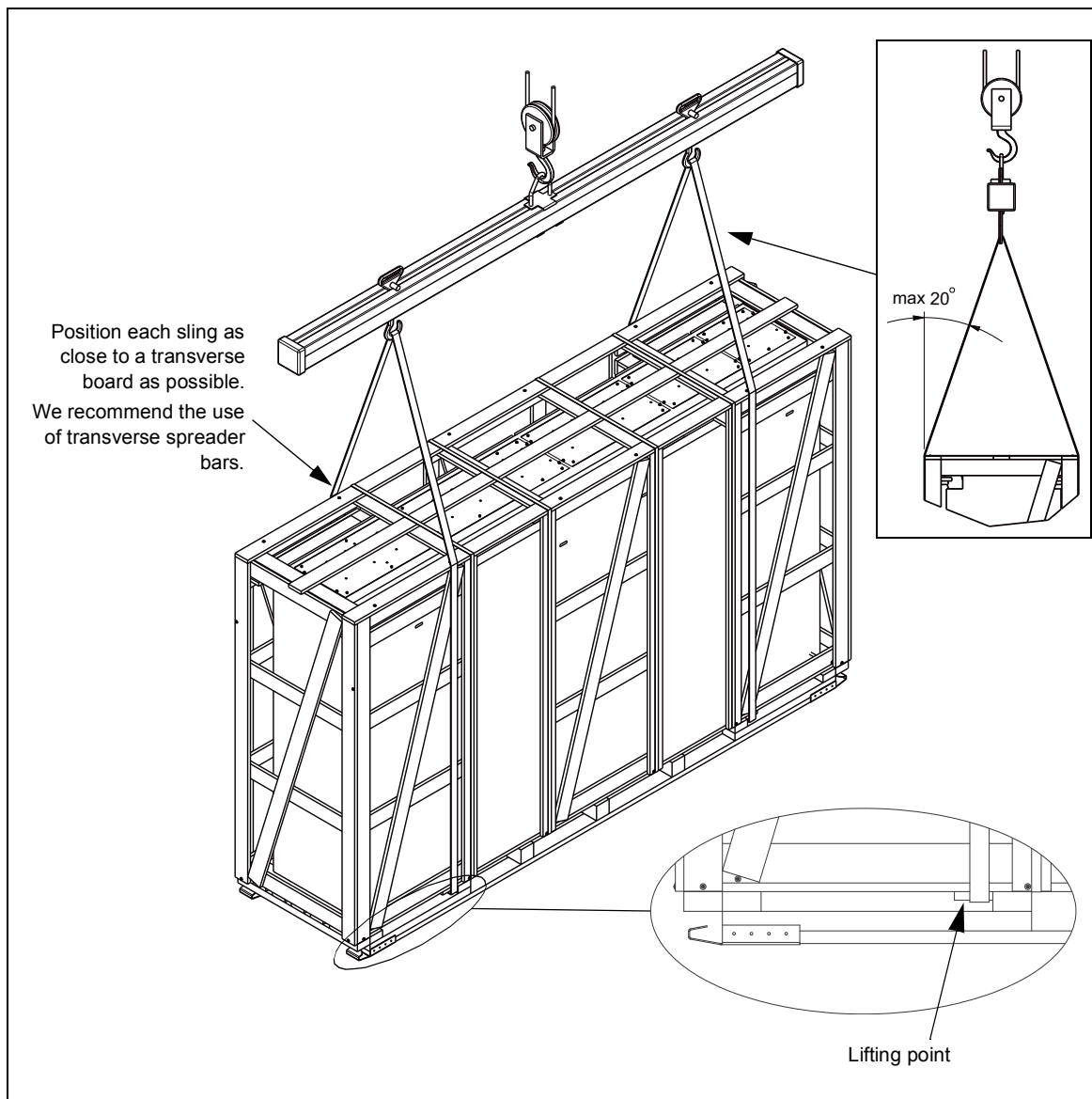

Moving the crate with a forklift

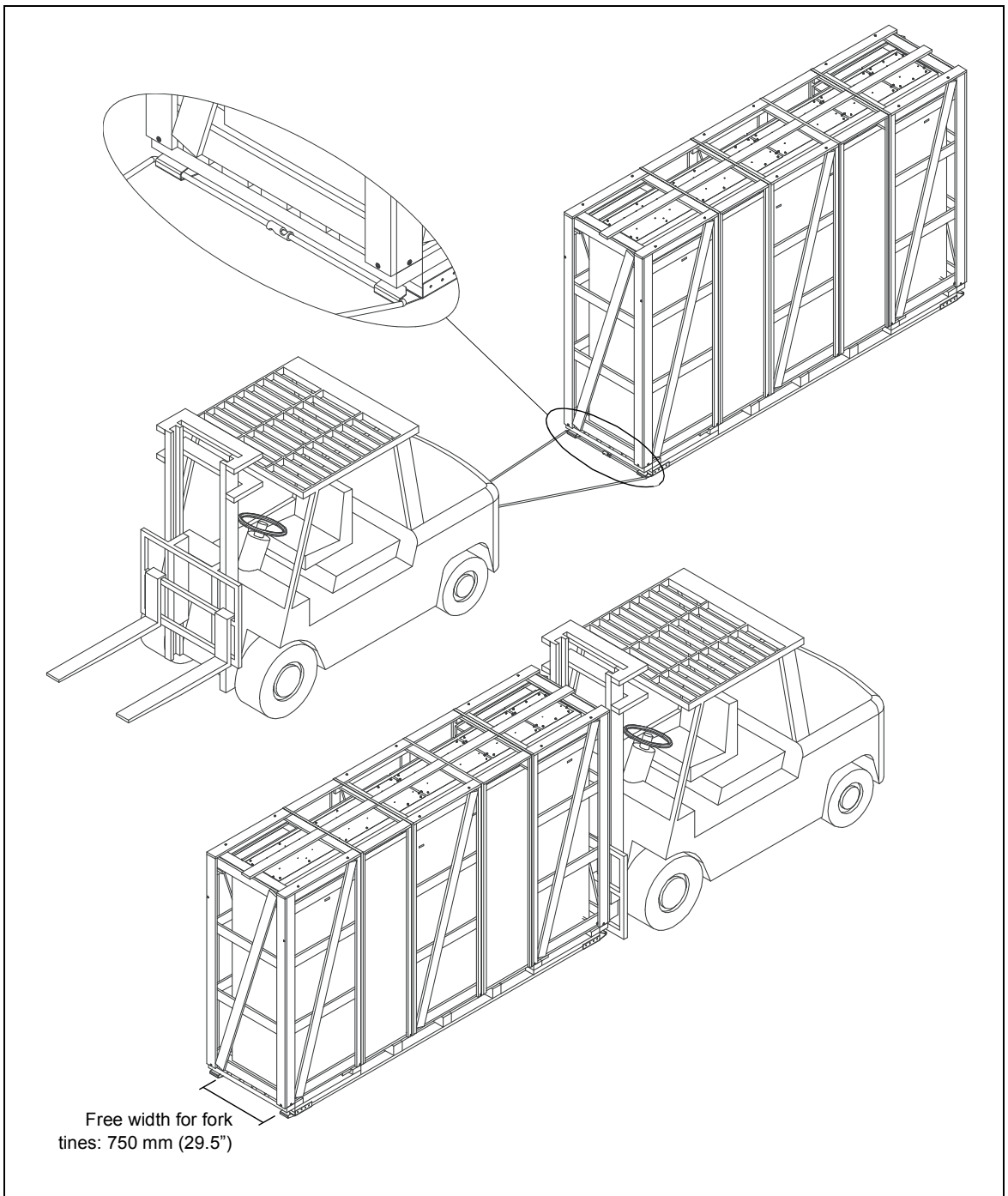

■ Removing the transport package

Remove the transport package as follows:

1. Undo the screws that attach the wooden parts of the transport crate together.
2. Remove the wooden parts.
3. Remove the clamps with which the drive cabinet is mounted onto the transport pallet by undoing the fastening screws.
4. Remove the plastic wrapping.

■ Moving the unpacked drive cabinet

Lifting the cabinet with a crane

Lift the drive cabinet using its lifting eyes. The lifting eyes can be removed after the cabinet is in its final position, but their mounting holes must be blocked to retain the degree of protection.

Note: The minimum allowed height of the lifting slings with IP54 units is 2 meters (6'7").

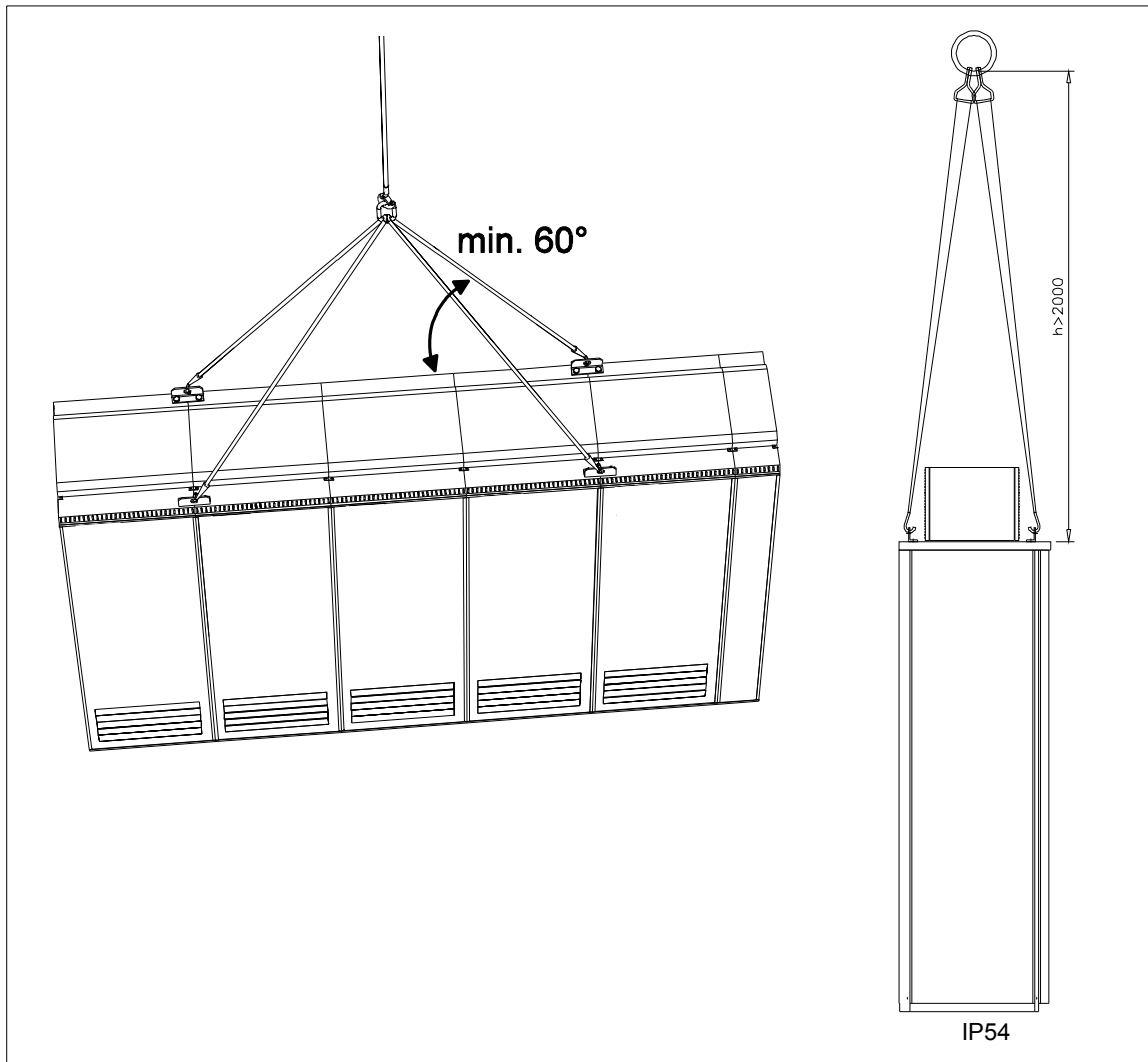

Moving the cabinet on rollers



WARNING: Do not move marine versions (option +C121) on rollers.

Lay the cabinet on the rollers and move it carefully until close to its final location. Remove the rollers by lifting the unit with a crane, forklift, pallet truck or jack.

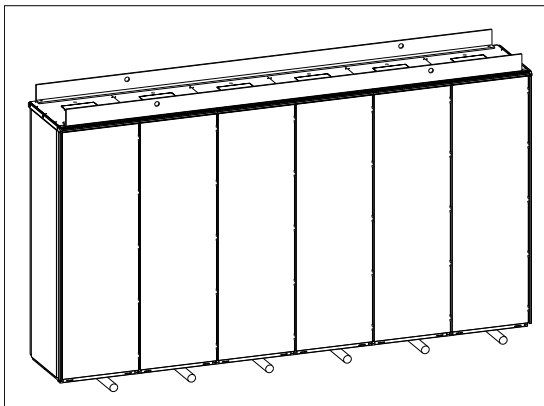

Moving the cabinet on its back



WARNING: Transportation of the cabinet on its back is only allowed with the sine filters (option +E206) removed from the cabinet.

Support the cabinet from below alongside the cubicle seams.

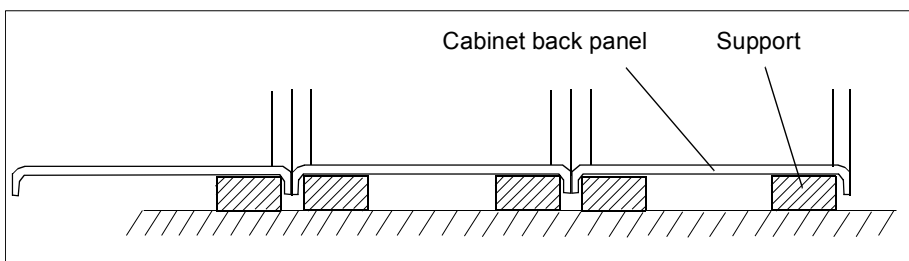

Final placement of the cabinet

Move the cabinet into its final position with a slate bar (spud bar). Place a piece of wood between the edge of the cabinet and the bar to protect the cabinet frame.

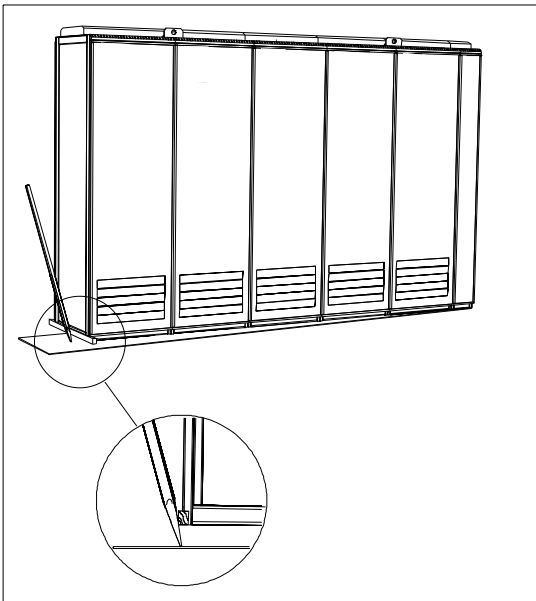

Fastening the cabinet to the floor and wall or roof (non-marine units)

■ General rules

- The drive must be installed in an upright vertical position.
- The cabinet can be installed with its back against a wall (a), or back-to-back with another unit (b).
- Leave 400 mm (15.75") of free space above the basic roof level of the cabinet for cooling. IP54 fan replacement requires 320 mm (12.28") of free space above the filter compartment.
- Leave some space (w) at the side where the cabinet outmost hinges are to allow the doors to open sufficiently. The doors must open 120° to allow supply or inverter module replacement.

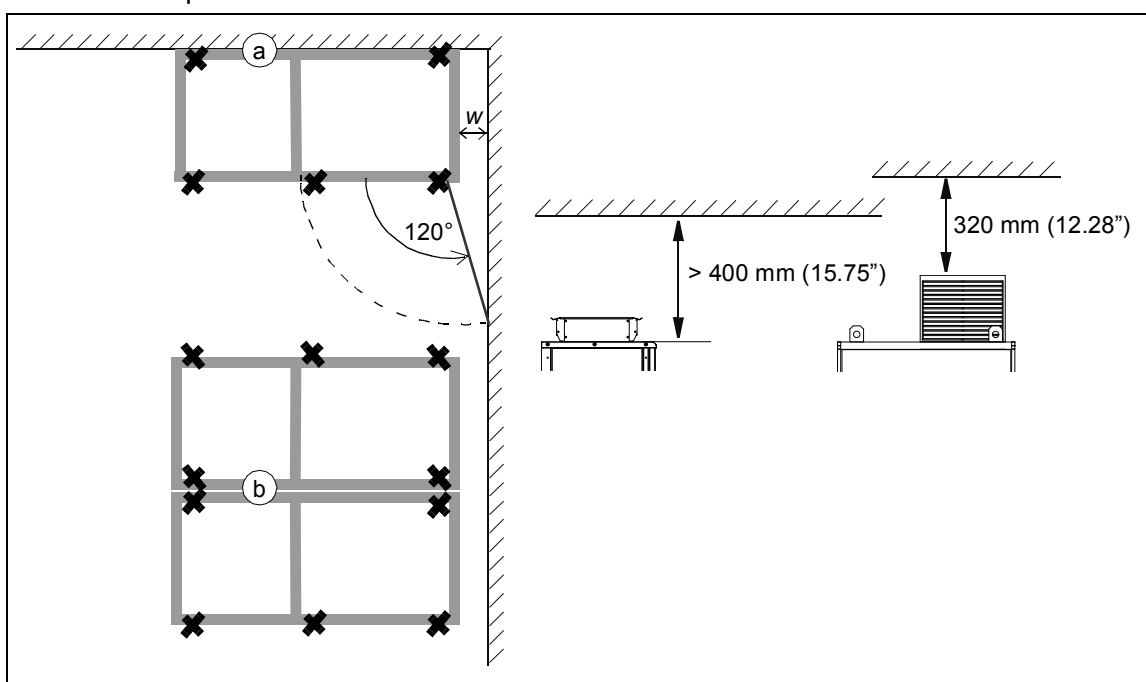

Note 1: Any height adjustment must be done before fastening the units or shipping splits together. Height adjustment can be done by using metal shims between the cabinet bottom and floor.

Note 2: If the lifting eyes are removed, refasten the bolts to retain the degree of protection of the cabinet.

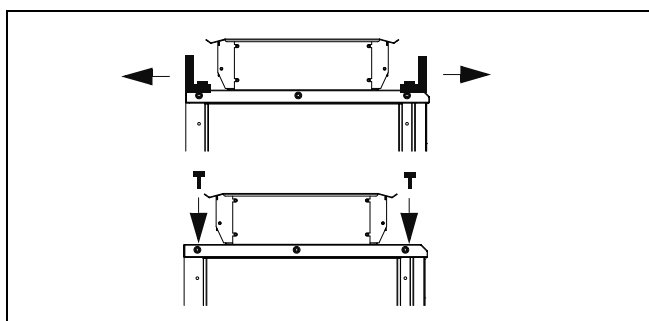

Fastening methods

Fasten the cabinet to the floor by using the clamps included along the edge of the cabinet bottom, or by bolting the cabinet to the floor through the holes inside (if they are accessible).

Alternative 1 – Clamping

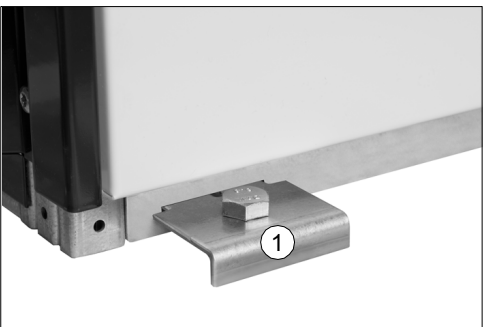
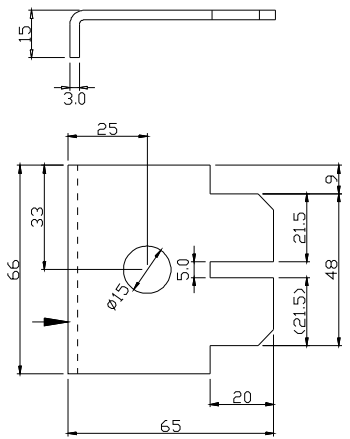
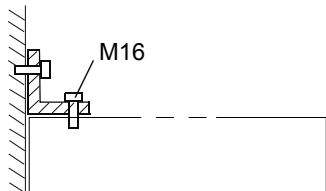
  <p style="text-align: center;">Clamp dimensions</p>	<ol style="list-style-type: none"> 1. Insert the clamps into the twin slots along the front and rear edges of the cabinet frame body and fasten them to the floor with a bolt. The recommended maximum distance between the clamps in the front edge is 800 mm (31.5”). 2. If floor mounting at the back is not possible, fasten the top of the cabinet to the wall with L-brackets (not included in the delivery) bolted to the lifting bar fastening holes. 
--	--

Alternative 2 – Using the holes inside the cabinet

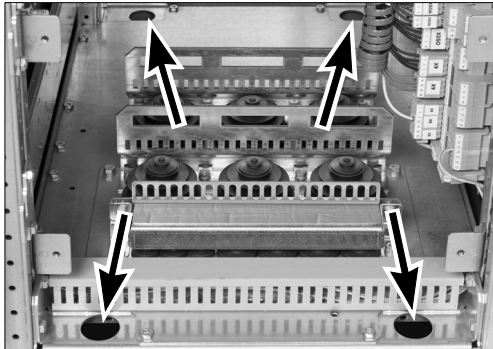
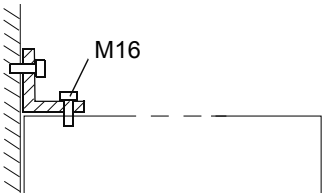
	<ol style="list-style-type: none"> 1. Fasten the cabinet to the floor through the bottom fastening holes with M10 to M12 (3/8” to 1/2”) bolts. The recommended maximum distance between the front edge fastening points is 800 mm (31.5”). 2. If the back fastening holes are not accessible, fasten the cabinet at the top to wall with L-brackets (not included in the delivery) using the lifting bar fastening holes. 
---	--

Fastening the cabinet to the floor and roof/wall (marine units)

Follow the general rules given in section [General rules](#) on page 65.

See the dimension drawing delivered with the drive for the locations of the fastening holes in the flat bars below the cabinet and for fastening points at the top of the cabinet. Top fastening brackets are included in the delivery.

Fasten the cabinet to the floor and roof (wall) as follows:

1. Bolt the unit to the floor through the holes in each flat bar at the base of the cabinet using M10 or M12 screws.
2. If there is not enough room behind the cabinet for installation, clamp the rear ends of the flat bars.
3. Remove the lifting lugs and bolt the fastening brackets into the lifting lug holes. Fasten the top of the cabinet to the rear wall and/or roof with brackets.

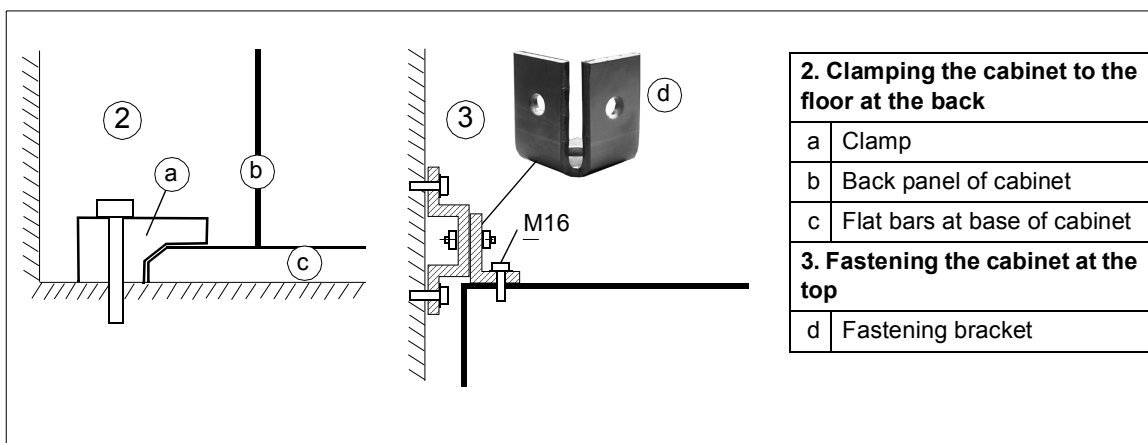

Joining shipping splits together

Wide cabinet line-ups are delivered in multiple parts called “shipping splits”. The connection is made using a 200 mm wide joining cubicle at the end of one shipping split (a common motor terminal cubicle can also act as a joining cubicle). The screws required for the joining are enclosed in a plastic bag inside the cabinet. The threaded bushings are already mounted on the cabinet posts.

1. Fasten the first shipping split to the floor.
2. Remove any plates covering the rear post of the joining cubicle.
3. Align the two shipping splits.
4. Fasten the front and rear posts of the joining cubicle to the posts of the other shipping split with 14 screws (7 per post). Tighten the screws to 5 N·m (3.6 lbf·ft).
5. Fasten the second shipping split to the floor.

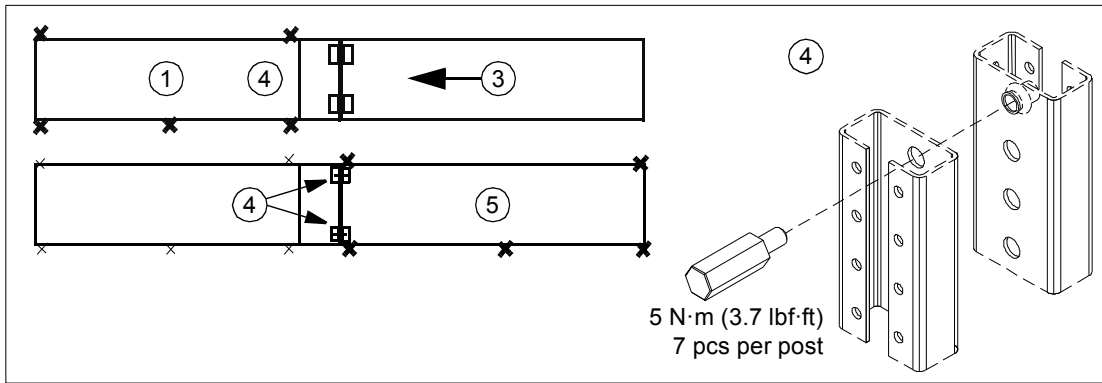

6. Connect the PE busbars using the M10 bolts and nuts included. Tighten to 35...40 N·m (25...30 lbf·ft).

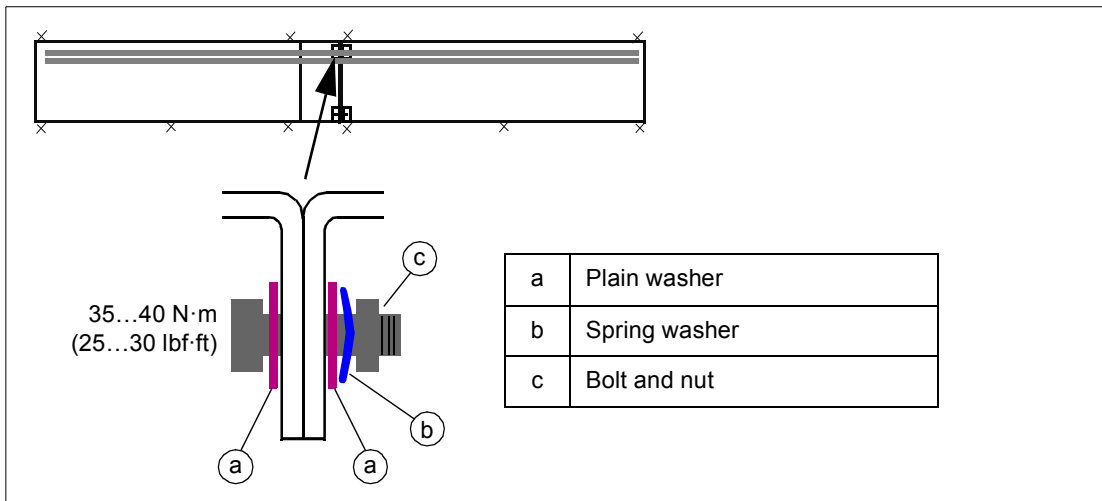

7. Remove the shroud covering the DC busbars in the joining cubicle.
8. Use the joint pieces to connect the DC busbars. Tighten the bolts to 55...70 N·m (40...50 lbf-ft).

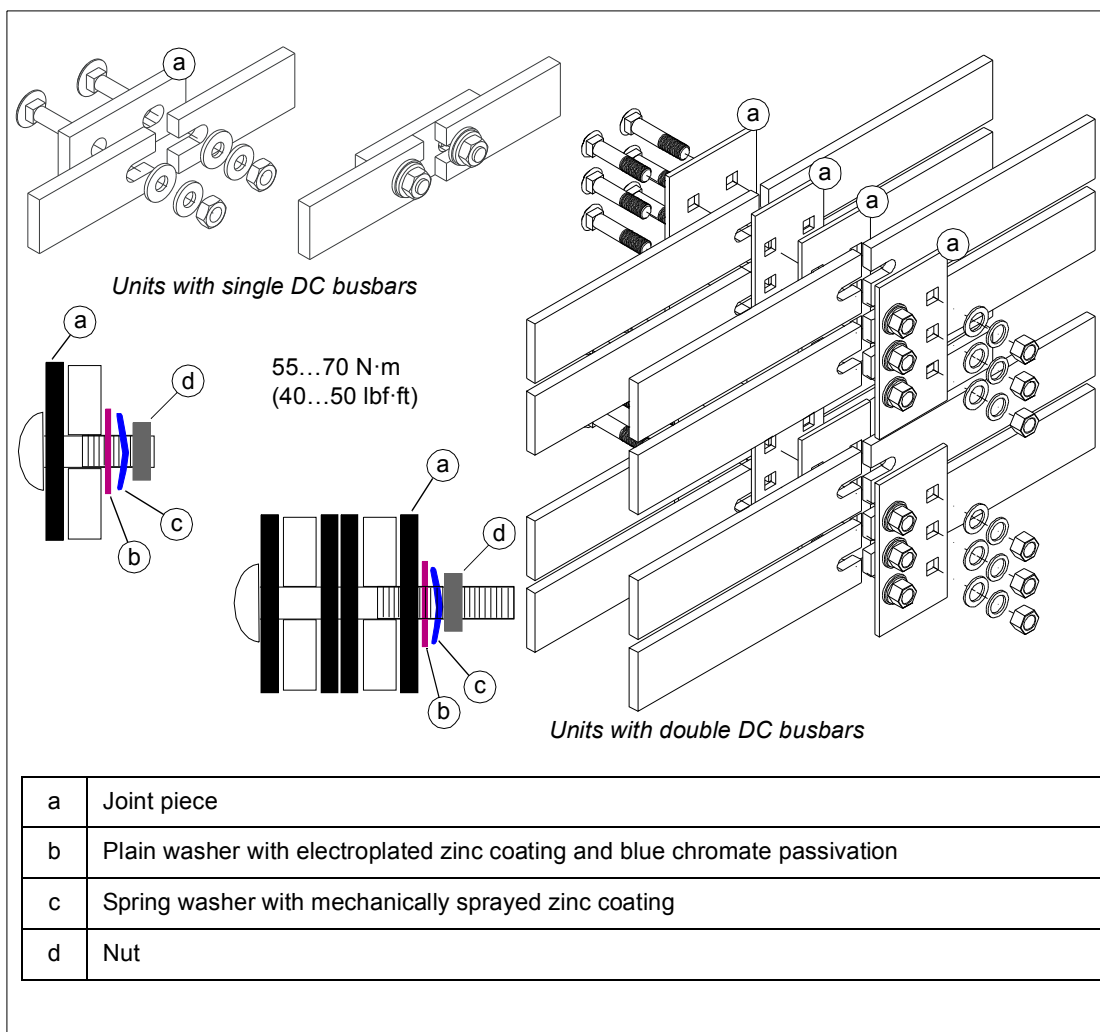

WARNING! Make sure you install the washers in the correct order as shown. For example, placing an unpassivated zinc-coated spring washer directly against the joint piece will cause corrosion.



WARNING! Do not use any joining parts other than those delivered with the unit. The parts are carefully selected to match the material of the busbars. Other parts or materials can form a galvanic couple and cause corrosion.

9. Reinstall any covering plates removed earlier.
10. Repeat steps 2 to 9 for any further shipping splits.



Miscellaneous

■ Cable duct in the floor below the cabinet

A cable duct can be constructed below the 500 mm wide middle part of the cabinet. The cabinet weight lies on the two 50 mm wide transverse sections which the floor must carry.

Prevent the cooling air flow from the cable duct to the cabinet by bottom plates. To ensure the degree of protection for the cabinet, use the original bottom plates delivered with the unit. With user-defined cable entries, take care of the degree of protection, fire protection and EMC compliance.

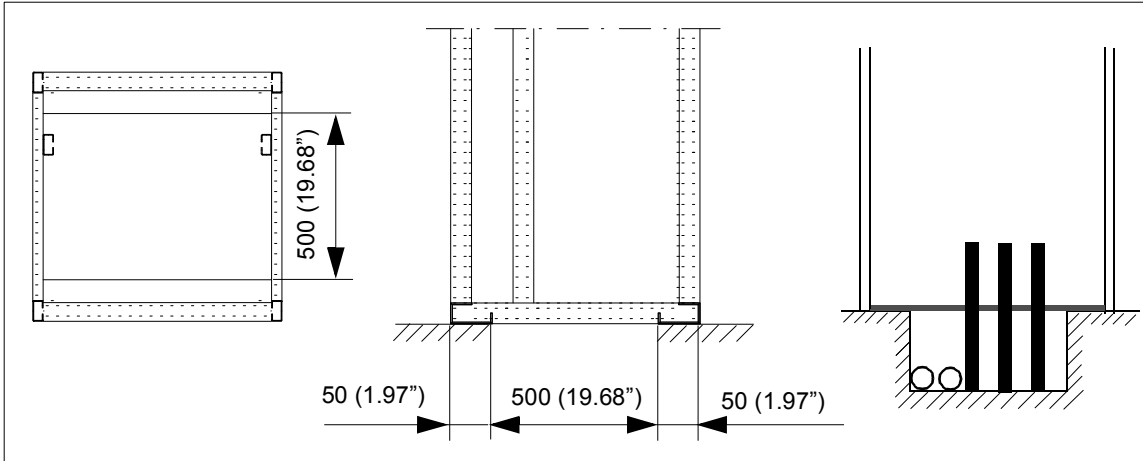

■ Air inlet through the bottom of cabinet (option +C128)

Drives with air intake through the bottom of the cabinet (option +C128) are intended for installation on an air duct in the floor. Each cubicle (except top entry adapter and joining cubicles) have an inlet through the bottom plate. The option also adds a 130 mm deep inlet area at the back of the cubicle.

An example of the air inlets in the cabinet bottom plate is shown below. Refer also to the dimension drawings delivered with the drive.

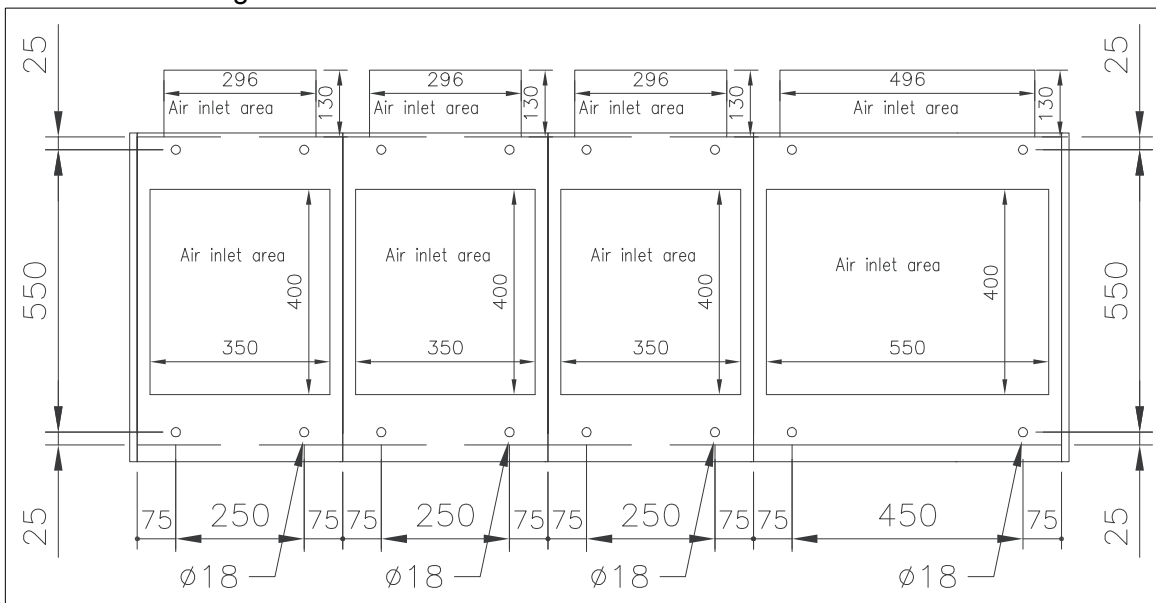

Support the plinth of the cabinet all round.

The air duct must be able to supply a sufficient volume of cooling air. The minimum air flow values are given in section [Cooling data, noise](#) (page 186).

Top cable entry adapter and joining cubicles have no air inlet.



WARNING! Make sure that the incoming air is sufficiently clean. If not, dust goes into the cabinet. The outlet filter on the cabinet roof prevents dust from going out. The collected dust can cause drive malfunction and danger of fire.

■ Air outlet duct on the cabinet roof (option +C130)

The ventilation system must keep the static pressure in the air outlet duct sufficiently below the pressure of the room where the drive is located in order that the cabinet fans can produce the required air flow through the cabinet. Make sure that no dirty or moist air is able to flow backward to the drive in any case, even during off-time or while servicing the drive or the ventilation system.

Calculating the required static pressure difference

The required static pressure difference between the exit air duct and the drive installation room can be calculated as follows:

$$\Delta p_s = (1.5 \dots 2) \cdot p_d$$

where

$$p_d = 0.5 \cdot \rho \cdot v_m^2$$

$$v_m = q / A_c$$

p_d $\hat{=}$ Dynamic pressure

ρ $\hat{=}$ Air density (kg/m³)

v_m $\hat{=}$ Average air velocity in the exit duct(s) (m/s)

q $\hat{=}$ Rated air flow of the drive (m³/s)

A_c $\hat{=}$ Cross-sectional area of the exit duct(s) (m²)

Example

The cabinet has 3 exit openings of 315 mm diameter. The rated air flow of the cabinet is 4650 m³/h = 1.3 m³/s.

$$A_c = 3 \cdot 0.315^2 \cdot \pi / 4 = 0.234 \text{ m}^2$$

$$v_m = q / A_c = 1.3 / 0.234 = 5.5 \text{ m/s}$$

$$p_d = 0.5 \cdot \rho \cdot v_m^2 = 0.5 \cdot 1.1 \cdot 5.5^2 = 17 \text{ Pa}$$

The required pressure in the exit air duct is then, 1.5...2 · 17 Pa = 26...34 Pa, below the pressure in the room.

For more information: Contact ABB.



■ Arc welding

Fastening the cabinet by arc welding is not recommended. However, if arc welding is the only mounting option, connect the return conductor of the welding equipment to the cabinet frame at the bottom within 0.5 meters (1'6") of the welding point.

Note: The thickness of the zinc coating of the cabinet frame is 100 to 200 micrometers (4 to 8 mil).



WARNING! Make sure that the return wire is connected correctly. Welding current must not return via any component or cabling of the drive. If the welding return wire is connected improperly, the welding circuit can damage electronic circuits in the cabinet.



WARNING! Do not inhale the welding fumes.



5

Guidelines for planning the electrical installation

Contents of this chapter

This chapter contains instructions for planning the electrical installation of the drive. Some instructions are mandatory to follow in every installation, others provide useful information that only concerns certain applications.

Limitation of liability

The installation must always be designed and made according to applicable local laws and regulations. ABB does not assume any liability whatsoever for any installation which breaches the local laws and/or other regulations. Furthermore, if the recommendations given by ABB are not followed, the drive may experience problems that the warranty does not cover.

Selecting the supply disconnecting device

The drive is equipped with a main disconnecting device. Depending on the size of the drive, and the selected options, the disconnecting device is a switch-disconnector or an air circuit breaker. The disconnecting device can be locked to the open position for installation and maintenance work.

Selecting the main contactor

Frame sizes 1×D8T + n×R8i, 2×D7T + 2×R8i and 2×D8T + n×R8i can be equipped with a line contactor (option +F250).

Examining the compatibility of the motor and drive

Use an asynchronous AC induction motor, permanent magnet synchronous motor or AC induction servomotor with the drive. Several induction motors can be connected to the drive at a time.

Select the motor size and drive type from the rating tables in chapter [Technical data](#) on basis of the AC line voltage and motor load. Use the DriveSize PC tool if you need to tune the selection more in detail.

Make sure that the motor withstands the maximum peak voltage in the motor terminals. See the [Requirements table](#) on page 75. For basics of protecting the motor insulation and bearings in drive systems, refer to section [Protecting the motor insulation and bearings](#) below.

Note:

- Consult the motor manufacturer before using a motor whose nominal voltage differs from the AC line voltage connected to the drive input.
- The voltage peaks at the motor terminals are relative to the supply voltage of the drive, not the drive output voltage.
- If the motor and drive are not of the same size, consider the following operation limits of the drive control program:
 - motor nominal voltage range $1/6 \dots 2 \cdot U_N$
 - motor nominal current range $1/6 \dots 2 \cdot I_N$ of the drive in DTC control and $0 \dots 2 \cdot I_N$ in scalar control. The control mode is selected by a drive parameter.

■ Protecting the motor insulation and bearings

The drive employs modern IGBT inverter technology. Regardless of frequency, the drive output comprises pulses of approximately the drive DC bus voltage with a very short rise time. The pulse voltage can almost double at the motor terminals, depending on the attenuation and reflection properties of the motor cable and the terminals. This can cause additional stress on the motor and motor cable insulation.

Modern variable speed drives with their fast rising voltage pulses and high switching frequencies can generate current pulses that flow through the motor bearings. This can gradually erode the bearing races and rolling elements.

Optional du/dt filters protect motor insulation system and reduce bearing currents. Optional common mode filters mainly reduce bearing currents. Insulated N-end (non-drive end) bearings protect the motor bearings.

■ Requirements table

The following table shows how to select the motor insulation system and when an optional drive du/dt and common mode filters and insulated N-end (non-drive end) motor bearings are required. Ignoring the requirements or improper installation may shorten motor life or damage the motor bearings and voids the warranty.

Motor type	Nominal AC supply voltage	Requirement for			
		Motor insulation system	ABB du/dt and common mode filters, insulated N-end motor bearings		
			$P_N < 100$ kW and frame size < IEC 315	100 kW $\leq P_N < 350$ kW or IEC 315 \leq frame size < IEC 400	$P_N \geq 350$ kW or frame size \geq IEC 400
			$P_N < 134$ hp and frame size < NEMA 500	134 hp $\leq P_N < 469$ hp or NEMA 500 \leq frame size \leq NEMA 580	$P_N \geq 469$ hp or frame size > NEMA 580
ABB motors					
Random-wound M2_, M3_ and M4_	$U_N \leq 500$ V	Standard	-	+ N	+ N + CMF
	500 V < $U_N \leq 600$ V	Standard	+ du/dt	+ N + du/dt	+ N + du/dt + CMF
		or			
	600 V < $U_N \leq 690$ V (cable length ≤ 150 m)	Reinforced	-	+ N	+ N + CMF
		Reinforced	+ du/dt	+ N + du/dt	+ N + du/dt + CMF
600 V < $U_N \leq 690$ V (cable length > 150 m)	Reinforced	-	+ N	+ N + CMF	
Form-wound HX_ and AM_	380 V < $U_N \leq 690$ V	Standard	n.a.	+ N + CMF	$P_N < 500$ kW: +N + CMF
					$P_N \geq 500$ kW +N + du/dt + CMF
Old* form-wound HX_ and modular	380 V < $U_N \leq 690$ V	Check with the motor manufacturer.	+ N + du/dt with voltages over 500 V + CMF		
Random-wound HX_ and AM_**	0 V < $U_N \leq 500$ V	Enamelled wire with fiber glass taping	+ N + CMF		
	500 V < $U_N \leq 690$ V		+ N + du/dt + CMF		
HDP	Consult the motor manufacturer.				

* manufactured before 1.1.1998

** For motors manufactured before 1.1.1998, check for additional instructions with the motor manufacturer.

Motor type	Nominal AC supply voltage	Requirement for			
		Motor insulation system	ABB du/dt and common mode filters, insulated N-end motor bearings		
			$P_N < 100$ kW and frame size < IEC 315	$100 \text{ kW} \leq P_N < 350$ kW or IEC 315 \leq frame size < IEC 400	$P_N \geq 350$ kW or frame size \geq IEC 400
$P_N < 134$ hp and frame size < NEMA 500	$134 \text{ hp} \leq P_N < 469$ hp or NEMA 500 \leq frame size \leq NEMA 580	$P_N \geq 469$ hp or frame size > NEMA 580			
Non-ABB motors					
Random-wound and form-wound	$U_N \leq 420$ V	Standard: $\dot{U}_{LL} = 1300$ V	-	+ N or CMF	+ N + CMF
	$420 \text{ V} < U_N \leq 500$ V	Standard: $\dot{U}_{LL} = 1300$ V	+ du/dt	+ du/dt + (N or CMF)	+ N + du/dt + CMF
		or	Reinforced: $\dot{U}_{LL} = 1600$ V, 0.2 microsecond rise time	-	+ N or CMF
	$500 \text{ V} < U_N \leq 600$ V	Reinforced: $\dot{U}_{LL} = 1600$ V	+ du/dt	+ du/dt + (N or CMF)	+ N + du/dt + CMF
		or	Reinforced: $\dot{U}_{LL} = 1800$ V	-	+ N or CMF
	$600 \text{ V} < U_N \leq 690$ V	Reinforced: $\dot{U}_{LL} = 1800$ V	+ du/dt	+ du/dt + N	+ N + du/dt + CMF
		Reinforced: $\dot{U}_{LL} = 2000$ V, 0.3 microsecond rise time ***	-	N + CMF	+ N + CMF

*** If the intermediate DC circuit voltage of the drive is increased from the nominal level by resistor braking, check with the motor manufacturer if additional output filters are needed in the applied drive operation range.

The abbreviations used in the table are defined below.

Abbr.	Definition
U_N	Nominal AC line voltage
\dot{U}_{LL}	Peak line-to-line voltage at motor terminals which the motor insulation must withstand
P_N	Motor nominal power
du/dt	du/dt filter at the output of the drive (standard equipment)
CMF	Common mode filter (standard equipment)
N	N-end bearing: insulated motor non-drive end bearing
n.a.	Motors of this power range are not available as standard units. Consult the motor manufacturer.

Additional requirements for explosion-safe (EX) motors

If you will use an explosion-safe (EX) motor, follow the rules in the requirements table above. In addition, consult the motor manufacturer for any further requirements.

Additional requirements for ABB motors of types other than M2_, M3_, M4_, HX_ and AM_

Use the selection criteria given for non-ABB motors.

Additional requirements for braking applications

When the motor brakes the machinery, the intermediate circuit DC voltage of the drive increases, the effect being similar to increasing the motor supply voltage by up to 20 percent. Consider this voltage increase when specifying the motor insulation requirements if the motor will be braking a large part of its operation time.

Example: Motor insulation requirement for a 400 V AC line voltage application must be selected as if the drive were supplied with 480 V.

Additional requirements for ABB high-output and IP23 motors

The rated output power of high output motors is higher than what is stated for the particular frame size in EN 50347 (2001). This table shows the requirements for ABB random-wound motor series (for example, M3AA, M3AP and M3BP).

Nominal mains voltage (AC line voltage)	Requirement for			
	Motor insulation system	ABB du/dt and common mode filters, insulated N-end motor bearings		
		$P_N < 100 \text{ kW}$	$100 \text{ kW} \leq P_N < 200 \text{ kW}$	$P_N \geq 200 \text{ kW}$
		$P_N < 140 \text{ hp}$	$140 \text{ hp} \leq P_N < 268 \text{ hp}$	$P_N \geq 268 \text{ hp}$
$U_N \leq 500 \text{ V}$	Standard	-	+ N	+ N + CMF
$500 \text{ V} < U_N \leq 600 \text{ V}$	Standard	+ du/dt	+ du/dt + N	+ du/dt + N + CMF
	or			
$600 \text{ V} < U_N \leq 690 \text{ V}$	Reinforced	-	+ N	+ N + CMF
	Reinforced	+ du/dt	+ du/dt + N	+ du/dt + N + CMF

Additional requirements for non-ABB high-output and IP23 motors

The rated output power of high-output motors is higher than what is stated for the particular frame size in EN 50347 (2001). If you plan to use a non-ABB high-output motor or an IP23 motor, consult the motor manufacturer.

Additional data for calculating the rise time and the peak line-to-line voltage

If you need to calculate the actual peak voltage and voltage rise time considering the actual cable length, proceed as follows:

- Peak line-to line voltage: Read the relative \hat{U}_{LL}/U_N value from the diagram below and multiply it by the nominal supply voltage (U_N).
- Voltage rise time: Read the relative values \hat{U}_{LL}/U_N and $(du/dt)/U_N$ from the diagram below. Multiply the values by the nominal supply voltage (U_N) and substitute into equation $t = 0.8 \cdot \hat{U}_{LL}/(du/dt)$.

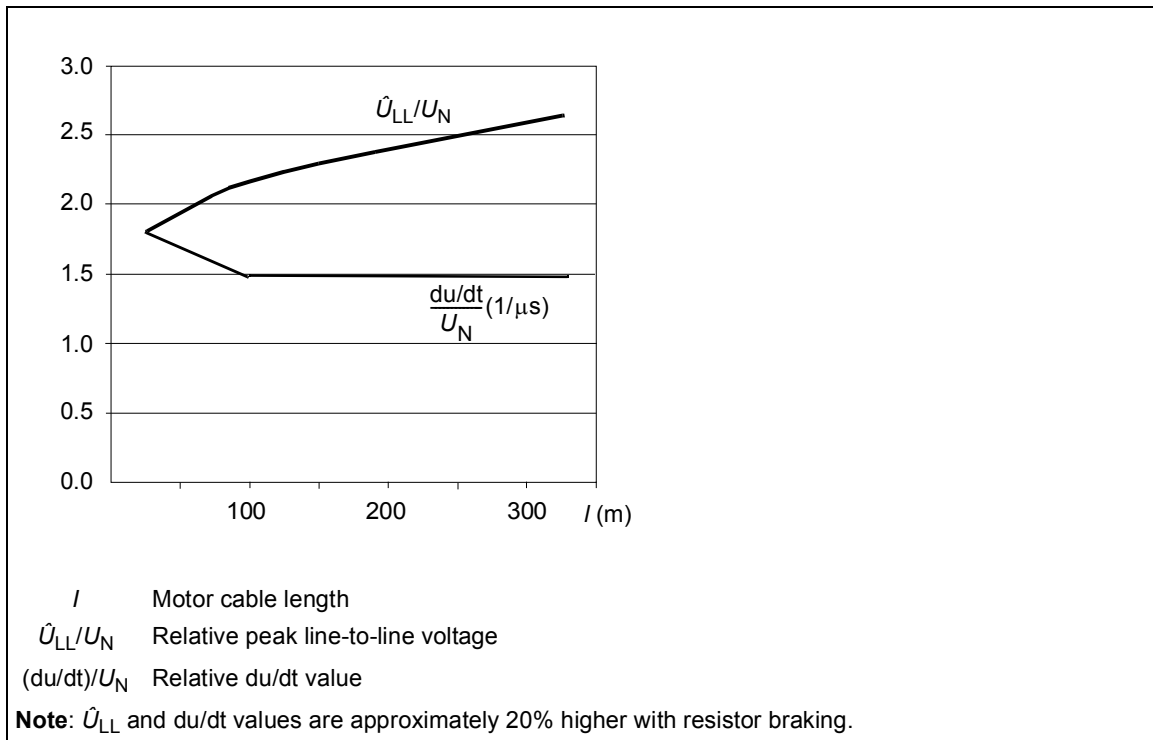

Selecting the power cables

■ General rules

Select the input power and motor cables according to local regulations:

- Select a cable capable of carrying the drive nominal current. See section [Ratings](#) (page 177) for the rated currents, and section [Typical cable sizes](#) (page 80) for typical cable sizes.
- Select a cable rated for at least 70 °C maximum permissible temperature of conductor in continuous use. For US, see [Additional US requirements](#), page 84.
- The inductance and impedance of the PE conductor/cable (grounding wire) must be rated according to permissible touch voltage appearing under fault conditions (so that the fault point voltage will not rise excessively when a ground fault occurs).
- 600 V AC cable is accepted for up to 500 V AC. 750 V AC cable is accepted for up to 600 V AC. For 690 V AC rated equipment, the rated voltage between the conductors of the cable should be at least 1 kV.

Use symmetrical shielded motor cable (see page 83). Ground motor cable shields 360° at both ends. Keep the motor cable and its PE pigtail (twisted shield) as short as possible to reduce high-frequency electromagnetic emissions.

Note: When continuous metal conduit is employed, shielded cable is not required. The conduit must have bonding at both ends.

A four-conductor system is allowed for input cabling, but shielded symmetrical cable is recommended.

Compared to a four-conductor system, the use of symmetrical shielded cable reduces electromagnetic emission of the whole drive system as well as the stress on motor insulation, bearing currents and wear.

The protective conductor must always have an adequate conductivity. The table below shows the minimum cross-sectional area related to the phase conductor size according to IEC 61439-1 when the phase conductor and the protective conductor are made of the same metal.

Cross-sectional area of the phase conductors S (mm ²)	Minimum cross-sectional area of the corresponding protective conductor S_p (mm ²)
$S \leq 16$	S
$16 < S \leq 35$	16
$35 < S \leq 400$	$S/2$
$400 < S \leq 800$	200

■ Typical cable sizes

Input (supply) cable sizes

The table below gives copper and aluminum cable types with concentric copper shield for nominal current. For drawings of the terminals, see chapter *Dimensions* (page 201).

Drive type ACS880-07-...	IEC ¹⁾		US ²⁾	
	Al cable size	Cu cable size	Cu cable size	Ground wire size
	mm ²	mm ²	AWG/kcmil	AWG/kcmil
U_N = 400 V				
0990A-3+A004	6 × (3 × 150 + 41 Cu)	4 × (3 × 240 + 120)	3 × 250	1/0
1140A-3	5 × (3 × 240 + 72 Cu)	4 × (3 × 240 + 120)	5 × 400	4/0
1140A-3+A004	6 × (3 × 185 + 57 Cu)	4 × (3 × 240 + 120)	3 × 300	3/0
1250A-3	6 × (3 × 240 + 72 Cu)	5 × (3 × 185 + 95)	6 × 350	3/0
1250A-3+A004	6 × (3 × 240 + 72 Cu)	6 × (3 × 150 + 70)	4 × 4/0	3/0
1480A-3	7 × (3 × 240 + 72 Cu)	5 × (3 × 240 + 120)	7 × 350	4/0
1480A-3+A004	8 × (3 × 185 + 57 Cu)	6 × (3 × 185 + 95)	4 × 300	4/0
1760A-3	8 × (3 × 240 + 72 Cu)	8 × (3 × 150 + 70)	7 × 500	4/0
1760A-3+A004	8 × (3 × 240 + 72 Cu)	8 × (3 × 150 + 70)	5 × 250	4/0
2210A-3	10 × (3 × 240 + 72 Cu)	9 × (3 × 185 + 95)	11 × 300	4/0
2210A-3+A004	10 × (3 × 240 + 72 Cu)	10 × (3 × 150 + 70)	7 × 4/0	3/0
2610A-3	12 × (3 × 240 + 72 Cu)	9 × (3 × 240 + 120)	12 × 350	4/0
2610A-3+A004	12 × (3 × 240 + 72 Cu)	12 × (3 × 150 + 70)	6 × 350	3/0
U_N = 500 V				
0990A-5+A004	6 × (3 × 150 + 41 Cu)	4 × (3 × 240 + 120)	3 × 250	1/0
1070A-5	5 × (3 × 240 + 72 Cu)	4 × (3 × 240 + 120)	6 × 250	4/0
1320A-5	6 × (3 × 240 + 72 Cu)	6 × (3 × 150 + 70)	6 × 350	4/0
1320A-5+A004	6 × (3 × 240 + 72 Cu)	6 × (3 × 150 + 70)	4 × 250	4/0
1450A-5	8 × (3 × 185 + 57 Cu)	5 × (3 × 240 + 120)	7 × 350	4/0
1450A-5+A004	8 × (3 × 185 + 57 Cu)	6 × (3 × 185 + 95)	4 × 250	4/0
1580A-5	7 × (3 × 240 + 72 Cu)	10 × (3 × 95 + 50)	8 × 300	4/0
1580A-5+A004	10 × (3 × 150 + 41 Cu)	8 × (3 × 150 + 70)	5 × 4/0	4/0
1800A-5	8 × (3 × 240 + 72 Cu)	6 × (3 × 240 + 120)	8 × 400	4/0
1800A-5+A004	8 × (3 × 240 + 72 Cu)	8 × (3 × 185 + 95)	6 × 4/0	4/0
1980A-5	9 × (3 × 240 + 72 Cu)	8 × (3 × 185 + 95)	10 × 300	4/0
1980A-5+A004	12 × (3 × 150 + 41 Cu)	8 × (3 × 185 + 95)	5 × 300	4/0
U_N = 690 V				
0800A-7	4 × (3 × 240 + 72 Cu)	3 × (3 × 240 + 120)	4 × 300	4/0
0800A-7+A004	4 × (3 × 240 + 72 Cu)	4 × (3 × 150 + 70)	2 × 300	1/0
0900A-7	4 × (3 × 240 + 72 Cu)	3 × (3 × 240 + 120)	4 × 400	4/0
0950A-7+A004	6 × (3 × 150 + 41 Cu)	4 × (3 × 185 + 95)	3 × 4/0	2/0
1160A-7	6 × (3 × 185 + 57 Cu)	4 × (3 × 240 + 120)	6 × 300	2/0
1160A-7+A004	6 × (3 × 185 + 57 Cu)	4 × (3 × 240 + 120)	3 × 300	2/0
1450A-7	8 × (3 × 185 + 57 Cu)	5 × (3 × 240 + 120)	7 × 350	4/0
1450A-7+A004	8 × (3 × 185 + 57 Cu)	6 × (3 × 185 + 95)	4 × 250	4/0
1650A-7	9 × (3 × 185 + 57 Cu)	7 × (3 × 185 + 95)	7 × 400	4/0
1650A-7+A004	10 × (3 × 150 + 41 Cu)	8 × (3 × 150 + 70)	4 × 350	4/0

Drive type ACS880-07-...	IEC ¹⁾		US ²⁾	
	Al cable size	Cu cable size	Cu cable size	Ground wire size
	mm ²	mm ²	AWG/kcmil	AWG/kcmil
1950A-7	9 × (3 × 240 + 72 Cu)	8 × (3 × 185 + 95)	9 × 350	4/0
1950A-7+A004	10 × (3 × 185 + 57 Cu)	8 × (3 × 185 + 95)	6 × 4/0	2/0
2300A-7	12 × (3 × 185 + 57 Cu)	8 × (3 × 240 + 120)	10 × 400	4/0
2300A-7+A004	12 × (3 × 185 + 57 Cu)	8 × (3 × 240 + 120)	6 × 300	2/0
2600A-7	14 × (3 × 185 + 57 Cu)	9 × (3 × 240 + 120)	11 × 400	4/0
2600A-7+A004	12 × (3 × 240 + 72 Cu)	12 × (3 × 150 + 70)	8 × 4/0	4/0
2860A-7	15 × (3 × 185 + 57 Cu)	15 × (3 × 120 + 70)	11 × 500	4/0
2860A-7+A004	12 × (3 × 300 + 88 Cu)	10 × (3 × 240 + 120)	8 × 250	4/0

+A004 = 12-pulse supply connection

1. The cable sizing is based on max. 9 cables laid on a cable ladder side by side, three ladder type trays one on top of the other, ambient temperature 30 °C, PVC insulation, surface temperature 70 °C (EN 60204-1 and IEC 60364-5-52/2001). For other conditions, size the cables according to local safety regulations, appropriate input voltage and the load current of the drive.
2. The cable sizing is based on NEC Table 310-15(B)(16) for copper wires, 75 °C (167 °F) wire insulation at 40 °C (104 °F) ambient temperature. Not more than three current-carrying conductors in raceway or cable or earth (directly buried). For other conditions, size the cables according to local safety regulations, appropriate input voltage and the load current of the drive.

Output (motor) cable sizes

The table below gives copper and aluminum cable types with concentric copper shield for nominal current. For drawings of the terminals, see chapter *Dimensions* (page 201).

Note: With no options selected, each inverter module of the drive is to be individually cabled to the motor. See also sections *Common motor terminal cubicle (option +H359)* (page 50) and *Common output terminal (option +H366)* (page 50).

Drive type ACS880-07-...	IEC ¹⁾		US ²⁾
	Al cable size	Cu cable size	Cu cable size
	mm ²	mm ²	AWG/kcmil
U_N = 400 V			
0990A-3+A004	6 × (3 × 150 + 70 Cu)	4 × (3 × 185 + 95)	5 × 300
1140A-3 1140A-3+A004	6 × (3 × 185 + 57 Cu)	4 × (3 × 240 × 120)	5 × 400
1250A-3 1250A-3+A004	6 × (3 × 240 + 72 Cu)	6 × (3 × 150 × 70)	6 × 350
1480A-3 1480A-3+A004	8 × (3 × 185 + 57 Cu)	6 × (3 × 185 × 95)	7 × 350
1760A-3 1760A-3+A004	8 × (3 × 240 + 72 Cu)	8 × (3 × 150 × 70)	7 × 500
2210A-3 2210A-3+A004	12 × (3 × 185 + 57 Cu)	9 × (3 × 185 × 95)	11 × 300
2610A-3 2610A-3+A004	12 × (3 × 240 + 72 Cu)	12 × (3 × 150 × 70)	12 × 350
U_N = 500 V			
0990A-5+A004	6 × (3 × 150 + 70 Cu)	4 × (3 × 185 × 95)	5 × 300
1070A-5	6 × (3 × 150 + 70 Cu)	4 × (3 × 185 × 95)	5 × 350
1320A-5	6 × (3 × 240 + 72 Cu)	6 × (3 × 150 × 70)	6 × 350
1320A-5+A004	8 × (3 × 185 + 57 Cu)	6 × (3 × 150 × 70)	6 × 350

82 Guidelines for planning the electrical installation

Drive type ACS880-07-...	IEC ¹⁾		US ²⁾
	Al cable size	Cu cable size	Cu cable size
	mm ²	mm ²	AWG/kcmil
1450A-5 1450-5+A004	8 × (3 × 185 + 57 Cu)	6 × (3 × 185 × 95)	7 × 350
1580A-5 1580A-5+A004	8 × (3 × 185 + 57 Cu)	8 × (3 × 150 × 70)	6 × 500
1800A-5 1800A-5+A004	9 × (3 × 240 + 72 Cu)	9 × (3 × 150 × 70)	8 × 400
1980A-5 1980A-5+A004	9 × (3 × 240 + 72 Cu)	9 × (3 × 150 × 70)	10 × 300
U_N = 690 V			
0800A-7 0800A-7+A004	6 × (3 × 120 + 41 Cu)	4 × (3 × 150 + 70)	4 × 300
0900A-7 0950A-7+A004	6 × (3 × 150 + 41 Cu)	4 × (3 × 185 + 95)	4 × 400
1160A-7 1160A-7+A004	6 × (3 × 185 + 57 Cu)	4 × (3 × 240 × 120)	6 × 300
1450A-7 1450A-7+A004	9 × (3 × 150 + 41 Cu)	6 × (3 × 185 + 95)	7 × 350
1650A-7 1650A-7+A004	9 × (3 × 185 + 57 Cu)	9 × (3 × 120 × 70)	7 × 400
1950A-7 1950A-7+A004	12 × (3 × 150 + 41 Cu)	8 × (3 × 185 + 95)	9 × 350
2300A-7	10 × (3 × 240 + 72 Cu)	10 × (3 × 185 × 95)	10 × 400
2300A-7+A004	12 × (3 × 185 + 57 Cu)	8 × (3 × 240 × 120)	10 × 400
2600A-7 2600A-7+A004	15 × (3 × 150 + 41 Cu)	15 × (3 × 120 × 70)	11 × 400
2860A-7 2860A-7+A004	15 × (3 × 185 + 57 Cu)	15 × (3 × 120 × 70)	11 × 500

+A004 = 12-pulse supply connection

1. The cable sizing is based on max. 9 cables laid on a cable ladder side by side, three ladder type trays one on top of the other, ambient temperature 30 °C, PVC insulation, surface temperature 70 °C (EN 60204-1 and IEC 60364-5-52/2001). For other conditions, size the cables according to local safety regulations, appropriate input voltage and the load current of the drive.
2. The cable sizing is based on NEC Table 310-15(B)(16) for copper wires, 75 °C (167 °F) wire insulation at 40 °C (104 °F) ambient temperature. Not more than three current-carrying conductors in raceway or cable or earth (directly buried). For other conditions, size the cables according to local safety regulations, appropriate input voltage and the load current of the drive.

Alternative power cable types

The recommended and not allowed power cable types to be used with the drive are presented below.

Recommended power cable types

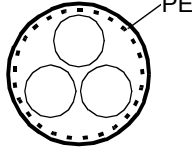
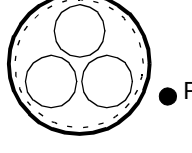
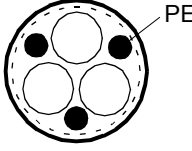
	<p>Symmetrical shielded cable with three phase conductors and a concentric PE conductor as shield. The shield must meet the requirements of IEC 61439-1, see page 78. Check with local / state / country electrical codes for allowance.</p>
	<p>Symmetrical shielded cable with three phase conductors and a concentric PE conductor as shield. A separate PE conductor is required if the shield does not meet the requirements of IEC 61439-1, see page 78.</p>
	<p>Symmetrical shielded cable with three phase conductors and symmetrically constructed PE conductor, and a shield. The PE conductor must meet the requirements of IEC 61439-1.</p>

Power cable types for limited use

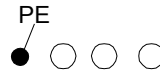
	<p>A four-conductor system (three phase conductors and a protective conductor on a cable tray) is not allowed for motor cabling (allowed for input cabling).</p>
---	---

Not allowed power cable types

	<p>Symmetrical shielded cable with individual shields for each phase conductor is not allowed on any cable size for input and motor cabling.</p>
---	--

Motor cable shield

If the motor cable shield is used as the sole protective earth conductor of the motor, make sure that the conductivity of the shield is sufficient. See subsection *General rules* above, or IEC 61439-1. To effectively suppress radiated and conducted radio-frequency emissions, the cable shield conductivity must be at least 1/10 of the phase conductor conductivity. The requirements are easily met with a copper or aluminum shield. The minimum requirement of the motor cable shield of the drive is shown below. It consists of a concentric layer of copper wires with an open helix of copper tape or copper wire. The better and tighter the shield, the lower the emission level and bearing currents.

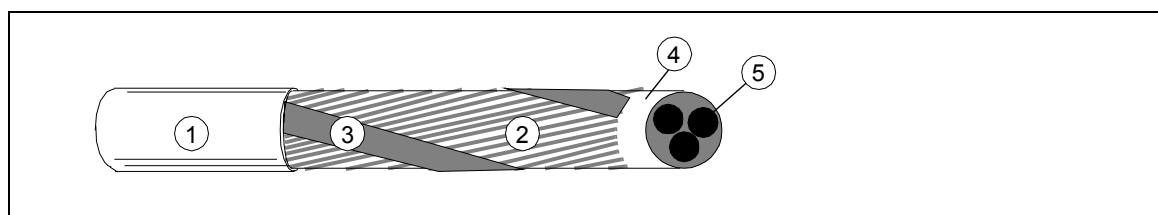

1	Insulation jacket
2	Copper wire screen
3	Helix of copper tape or copper wire
4	Inner insulation
5	Cable core

■ Additional US requirements

Use type MC continuous corrugated aluminum armor cable with symmetrical grounds or shielded power cable for the motor cables if metallic conduit is not used. For the North American market, 600 V AC cable is accepted for up to 500 V AC. 1000 V AC cable is required above 500 V AC (below 600 V AC). For drives rated over 100 amperes, the power cables must be rated for 75 °C (167 °F).

Conduit

Couple separate parts of a conduit together: bridge the joints with a ground conductor bonded to the conduit on each side of the joint. Also bond the conduits to the drive enclosure and motor frame. Use separate conduits for input power, motor, brake resistor, and control wiring. When conduit is employed, type MC continuous corrugated aluminum armor cable or shielded cable is not required. A dedicated ground cable is always required.

Note: Do not run motor wiring from more than one drive in the same conduit.

Armored cable / shielded power cable

Six conductor (3 phases and 3 ground) type MC continuous corrugated aluminum armor cable with symmetrical grounds is available from the following suppliers (trade names in parentheses):

- Anixter Wire & Cable (Philsheath)
- BICC General Corp (Philsheath)
- Rockbestos Co. (Gardex)
- Oaknite (CLX).

Shielded power cables are available from Belden, LAPPKABEL (ÖLFLEX) and Pirelli.

Planning the braking system

See chapter [Resistor braking](#).

Selecting the control cables

■ Shielding

All control cables must be shielded.

Use a double-shielded twisted pair cable for analog signals. This type of cable is recommended for the pulse encoder signals also. Employ one individually shielded pair for each signal. Do not use common return for different analog signals.

A double-shielded cable (figure a below) is the best alternative for low-voltage digital signals but single-shielded (b) twisted pair cable is also acceptable.

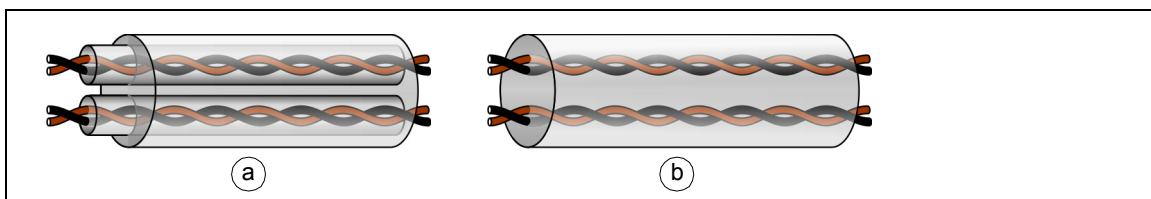

■ Signals in separate cables

Run analog and digital signals in separate, shielded cables. Never mix 24 V DC and 115/230 V AC signals in the same cable.

■ Signals allowed to be run in the same cable

Relay-controlled signals, providing their voltage does not exceed 48 V, can be run in the same cables as digital input signals. The relay-controlled signals should be run as twisted pairs.

■ Relay cable type

The cable type with braided metallic screen (for example ÖLFLEX by LAPPKABEL, Germany) has been tested and approved by ABB.

■ Control panel cable length and type

In remote use, the cable connecting the control panel to the drive must not be longer than three meters (10 ft). Cable type: shielded CAT 5e or better Ethernet patch cable with RJ-45 ends.

Routing the cables

Route the motor cable away from other cable routes. Motor cables of several drives can be run in parallel installed next to each other. The motor cable, input power cable and control cables should be installed on separate trays. Avoid long parallel runs of motor cables with other cables in order to decrease electromagnetic interference caused by the rapid changes in the drive output voltage.

Where control cables must cross power cables, make sure they are arranged at an angle as near to 90 degrees as possible. Do not run extra cables through the drive.

The cable trays must have good electrical bonding to each other and to the grounding electrodes. Aluminum tray systems can be used to improve local equalizing of potential.

A diagram of the cable routing is shown below.

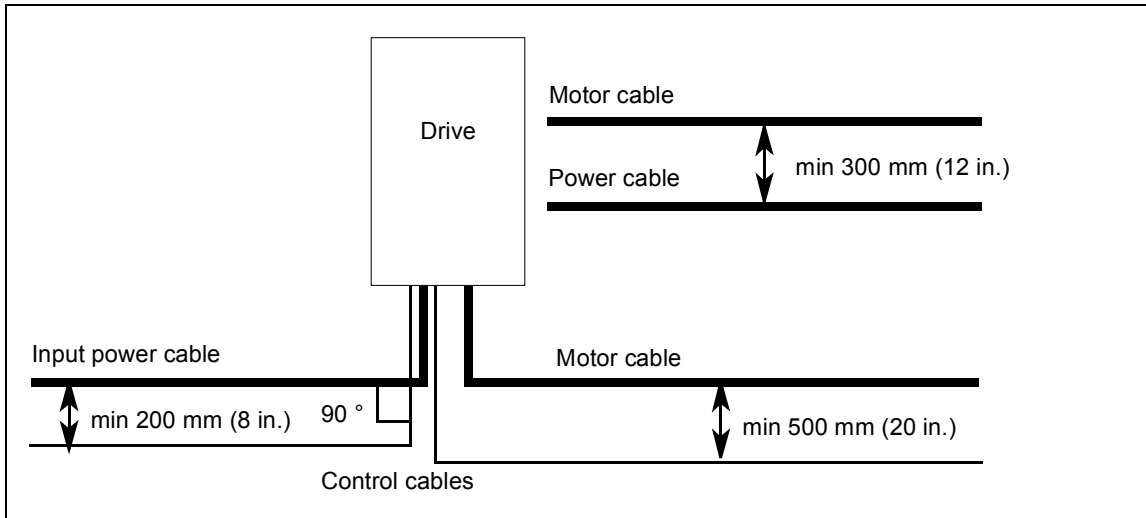

■ Separate control cable ducts

Lead 24 V and 230 V (120 V) control cables in separate ducts unless the 24 V cable is insulated for 230 V (120 V) or insulated with an insulation sleeving for 230 V (120 V).

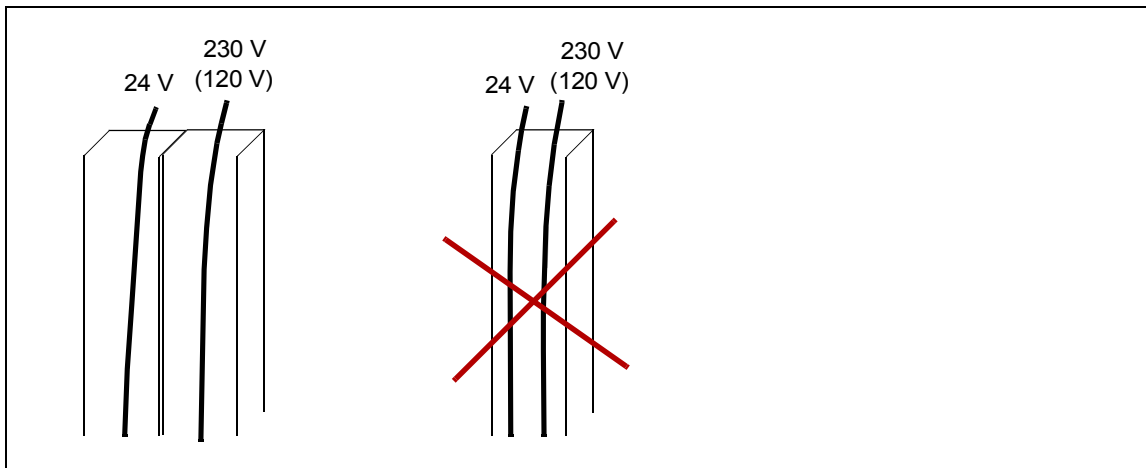

■ Continuous motor cable shield or enclosure for equipment on the motor cable

To minimize the emission level when safety switches, contactors, connection boxes or similar equipment are installed on the motor cable between the drive and the motor:

- European Union: Install the equipment in a metal enclosure with 360 degree grounding for the shields of both the incoming and outgoing cable, or connect the shields of the cables otherwise together.
- US: Install the equipment in a metal enclosure in a way that the conduit or motor cable shielding runs consistently without breaks from the drive to the motor.

Implementing thermal overload and short-circuit protection

■ Protecting the drive and input power cable in short-circuits

The drive is equipped with internal AC fuses as standard. Protect the input cable with fuses or a suitable circuit breaker. Size the input cable fuses according to the instructions given in chapter [Technical data](#). The fuses will protect the input cable in short-circuit situations, restrict drive damage and prevent damage to adjoining equipment in case of a short-circuit inside the drive.

■ Protecting the motor and motor cable in short-circuits

The drive protects the motor cable and motor in a short-circuit situation when the motor cable is sized according to the nominal current of the drive. No additional protection devices are needed.

■ Protecting the drive and the power cables against thermal overload

The drive protects itself and the input and motor cables against thermal overload when the cables are sized according to the nominal current of the drive. No additional thermal protection devices are needed.



WARNING! If the drive is connected to multiple motors, use a separate circuit breaker or fuses for protecting each motor cable and motor against overload. The drive overload protection is tuned for the total motor load. It may not trip due to an overload in one motor circuit only.

■ Protecting the motor against thermal overload

According to regulations, the motor must be protected against thermal overload and the current must be switched off when overload is detected. The drive includes a motor thermal protection function that protects the motor and switches off the current when necessary. Depending on a drive parameter value, the function either monitors a calculated temperature value (based on a motor thermal model) or an actual temperature indication given by motor temperature sensors. The user can tune the thermal model further by feeding in additional motor and load data.

The most common temperature sensors are:

- motor sizes IEC180...225: thermal switch, eg. Klixon
- motor sizes IEC200...250 and larger: PTC or Pt100.

See the firmware manual for more information on the motor thermal protection, and the connection and use of the temperature sensors.

Protecting the drive against ground faults

The drive is equipped with an internal ground fault protective function to protect the unit against ground faults in the motor and motor cable in TN (grounded) networks. This is not a personnel safety or a fire protection feature. The ground fault protective function can be disabled with a parameter, refer to the firmware manual.

An optional ground fault monitoring device (+Q954) is available for IT (ungrounded) systems. The option includes a ground fault indicator on the drive cabinet door.

■ Residual current device compatibility

The drive is suitable to be used with residual current devices of Type B.

Note: The EMC filter of the drive includes capacitors connected between the main circuit and the frame. These capacitors and long motor cables increase the ground leakage current and may cause fault current circuit breakers to function.

Implementing the emergency stop function

The drive can be equipped with a category 0 or 1 emergency stop function. For safety reasons, install the emergency stop devices at each operator control station and at other operating stations where emergency stop may be needed.

Note: Pressing the stop key  on the control panel of the drive, or turning the operating switch of the drive from position “1” to “0” does not generate an emergency stop of the motor or separate the drive from dangerous potential.

See the appropriate emergency stop user’s manual for the wiring, start-up and operation instructions.

Option code	User’s manual	Manual code (English)
+Q951	Emergency stop, stop category 0 (using main contactor/breaker)	3AUA0000119895
+Q952	Emergency stop, stop category 1 (using main contactor/breaker)	3AUA0000119896
+Q963	Emergency stop, stop category 0 (using Safe torque off)	3AUA0000119908
+Q964	Emergency stop, stop category 1 (using Safe torque off)	3AUA0000119909
+Q978	Emergency stop, stop category 0 or 1 (using main contactor/breaker and Safe torque off)	3AUA0000145920
+Q979	Emergency stop, stop category 0 or 1 (using Safe torque off)	3AUA0000145921

Implementing the Safe torque off function

See chapter [The Safe torque off function](#) (page 249).

Implementing the Prevention of unexpected start-up function

The drive can be equipped with a Prevention of unexpected start-up (POUS) function either with an FSO-xx safety functions module (option +Q950) or with a safety relay (option +Q957). The POUS function enables short-time maintenance work (like cleaning) on the non-electrical parts of the machinery without switching off and disconnecting the drive.

See the appropriate user’s manual for the wiring, start-up and operation instructions.

Option code	User’s manual	Manual code (English)
+Q950	Prevention of unexpected start-up, with FSO-xx safety functions module	3AUA0000145922
+Q957	Prevention of unexpected start-up, with safety relay	3AUA0000119910

Implementing the functions provided by the FSO-xx safety functions module (option +Q972 or +Q973)

The drive can be equipped with an FSO-xx safety functions module (option +Q972 or +Q973) which enables the implementation of functions such as Safe brake control (SBC), Safe stop 1 (SS1), Safe stop emergency (SSE), Safely limited speed (SLS) and Safe maximum speed (SMS).

The settings of the FSO-xx are at default when delivered from the factory. The connectors of the module are pre-wired to terminal block X68. The wiring of the external safety circuit and configuration of the FSO-xx module are the responsibility of the machine builder.

The FSO-xx reserves the standard Safe torque off (STO) connection of the inverter control unit. STO can still be utilized by other safety circuits through the FSO-xx.

For wiring instructions, safety data and more information on the functions provided by the FSO-xx, refer to its manual.

■ Declaration of Conformity

See page [194](#).

Implementing the Power-loss ride-through function

Implement the power-loss ride-through function as follows:

Check that the power-loss ride-through function of the inverter unit is enabled with parameter **30.31 Undervoltage control** in the ACS880 primary control program.



WARNING! Make sure that the flying restart of the motor will not cause any danger. If you are in doubt, do not implement the Power-loss ride-through function.

■ Units with main contactor (option +F250)

The main contactor of the drive opens in a power-loss situation. When the power returns, the contactor closes. However, if the power-loss situation lasts so long that the drive trips on undervoltage, it must be reset and started again to continue operation. If the power-loss situation lasts so long that the buffer module (see page [40](#)) runs out, the main contactor remains open and the drive operates only after reset and a new start.

With external uninterruptible control voltage (option +G307), the main contactor remains closed in power-loss situations. If the power-loss situation lasts so long that the drive trips on undervoltage, it must be reset and started again to continue operation.

Supplying power for the auxiliary circuits

The drive is equipped with an auxiliary control voltage transformer which supplies control voltage, for example, for the control devices and cabinet fan(s).

The following options are to be supplied from external power sources:

- +G300/+G301: Cabinet heaters and/or lighting (230 or 115 V AC; external fuse: 16 A gG)
- +G307: Connection for an external uninterruptible power supply (230 or 115 V AC; external fuse 16 A gG) to the control unit and control devices when the drive is not powered
- +G313: Power supply connection (230 V AC; external fuse 16 A gG) for a motor space heater output.

Using power factor compensation capacitors with the drive

Power factor compensation is not needed with AC drives. However, if a drive is to be connected in a system with compensation capacitors installed, note the following restrictions.



WARNING! Do not connect power factor compensation capacitors or harmonic filters to the motor cables (between the drive and the motor). They are not meant to be used with AC drives and can cause permanent damage to the drive or themselves.

If there are power factor compensation capacitors in parallel with the three phase input of the drive:

1. Do not connect a high-power capacitor to the power line while the drive is connected. The connection will cause voltage transients that may trip or even damage the drive.
2. If capacitor load is increased/decreased step by step when the AC drive is connected to the power line, make sure that the connection steps are low enough not to cause voltage transients that would trip the drive.
3. Check that the power factor compensation unit is suitable for use in systems with AC drives, ie, harmonic generating loads. In such systems, the compensation unit should typically be equipped with a blocking reactor or harmonic filter.

Implementing a safety switch between the drive and the motor

We recommend to install a safety switch between the permanent magnet synchronous motor and the drive output. The switch is needed to isolate the motor during any maintenance work on the drive.

Protecting the contacts of relay outputs

Inductive loads (relays, contactors, motors) cause voltage transients when switched off.

The relay contacts on the drive control unit are protected with varistors (250 V) against overvoltage peaks. In spite of this, it is highly recommended that inductive loads are equipped with noise attenuating circuits (varistors, RC filters [AC] or diodes [DC]) in order

to minimize the EMC emission at switch-off. If not suppressed, the disturbances may connect capacitively or inductively to other conductors in the control cable and form a risk of malfunction in other parts of the system.

Install the protective component as close to the inductive load as possible. Do not install protective components at the relay outputs.

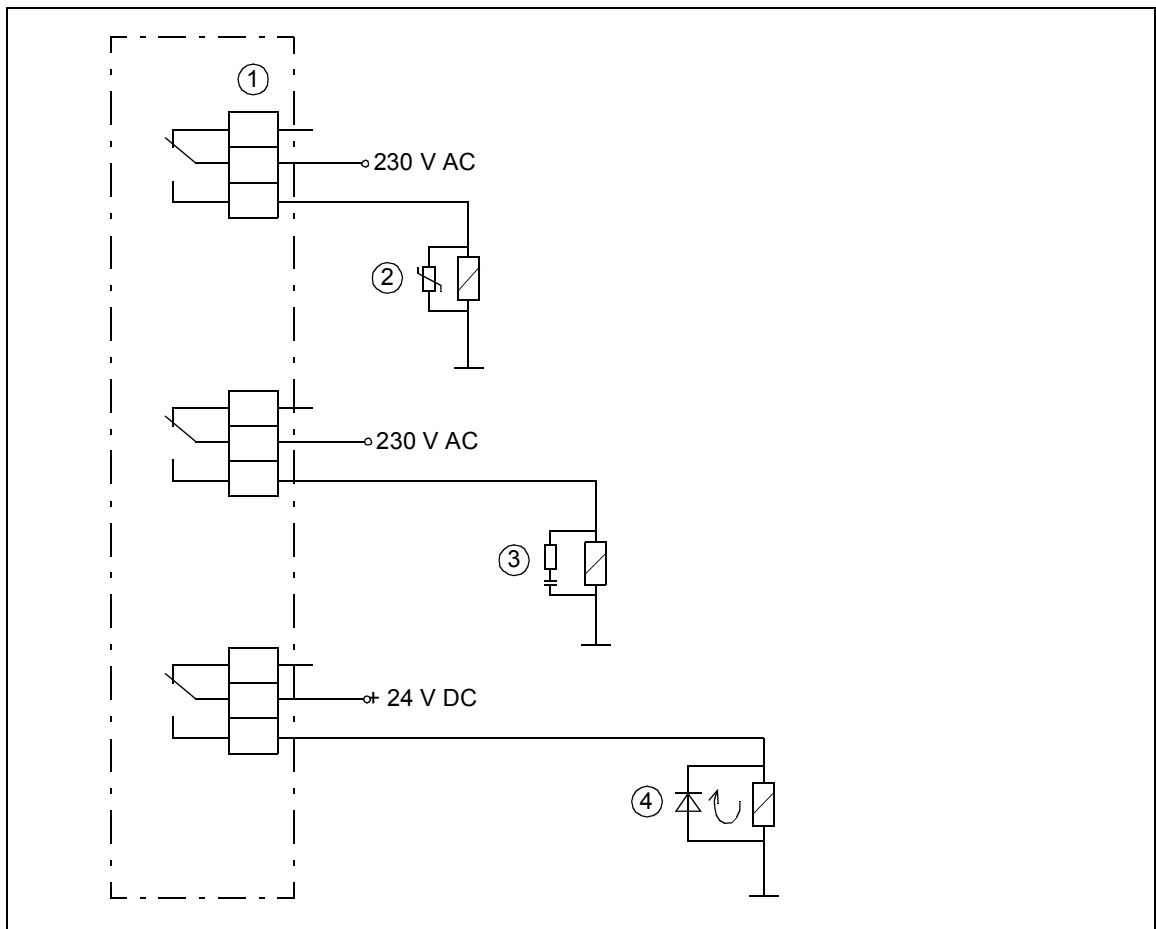

1) Relay outputs; 2) Varistor; 3) RC filter; 4) diode

Connecting a motor temperature sensor to the drive I/O



WARNING! IEC 60664 requires double or reinforced insulation between live parts and the surface of accessible parts of electrical equipment which are either non-conductive or conductive but not connected to the protective earth.

To fulfill this requirement, the connection of a thermistor (and other similar components) to the digital inputs of the drive can be implemented in three alternate ways:

1. There is double or reinforced insulation between the thermistor and live parts of the motor.
 2. Circuits connected to all digital and analog inputs of the drive are protected against contact and insulated with basic insulation (the same voltage level as the drive main circuit) from other low voltage circuits.
 3. An external thermistor relay is used. The insulation of the relay must be rated for the same voltage level as the main circuit of the drive. For connection, see the firmware manual.
-

6

Electrical installation

Contents of this chapter

This chapter gives instructions on the wiring the drive.

Warnings



WARNING! Only qualified electricians are allowed to carry out the work described in this chapter. Follow the [Safety instructions](#) on the first pages of this manual. Ignoring the safety instructions can cause injury or death.



Checking the insulation of the assembly

■ Drive

Do not make any voltage tolerance or insulation resistance tests on any part of the drive as testing can damage the drive. Every drive has been tested for insulation between the main circuit and the chassis at the factory. Also, there are voltage-limiting circuits inside the drive which cut down the testing voltage automatically.

■ Input cable

Check the insulation of the input cable according to local regulations before connecting it to the drive.

■ Motor and motor cable

1. Check that the motor cable is disconnected from the drive output terminals U2, V2 and W2.
2. Measure the insulation resistance between each phase conductor and the Protective Earth conductor using a measuring voltage of 1000 V DC. The insulation resistance of an ABB motor must exceed 100 Mohm (reference value at 25 °C or 77 °F). For the insulation resistance of other motors, consult the manufacturer's instructions. **Note:** Moisture inside the motor casing will reduce the insulation resistance. If moisture is suspected, dry the motor and repeat the measurement.

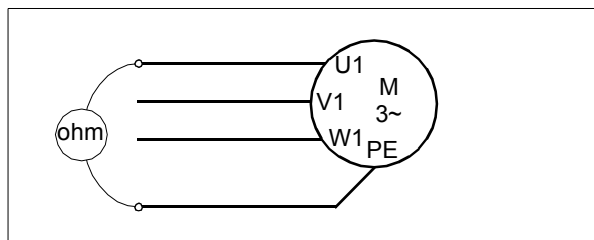

■ Custom brake resistor assembly

See section [Connection procedure](#) (page 268).

Checking the compatibility with IT (ungrounded) systems

EMC filter +E202 is not suitable for use in an IT (ungrounded) system. If the drive is equipped with filter +E202, disconnect the filter before connecting the drive to the supply network. For instructions on how to do this, contact your local ABB representative.



WARNING! If a drive with EMC filter +E202 is installed on an IT system (an ungrounded power system or a high resistance-grounded [over 30 ohm] power system), the system will be connected to earth potential through the EMC filter capacitors of the drive. This may cause danger, or damage the unit.

Attaching the device stickers to the cabinet door

A multilingual device label sticker is delivered with the drive. Attach the stickers in the local language on the English texts; see section [Door switches and lights](#) (page 44).

Checking the settings of transformers T21 and T101 and T111

Check the tap settings of all auxiliary voltage transformers. Transformer T21 is standard equipment; T101 and T111 are present depending on drive configuration.

The voltage settings of transformers T21 and T101 are made at terminal blocks T21_X1/X2 and T101_X1/X2 respectively. The settings of transformer T111 are made on the transformer itself. The locations of the transformers and the terminal blocks are shown in section [Auxiliary control cubicle \(ACU\) layout](#) (page 40).

■ **T21 and T101 tap settings (400...500 V units)**

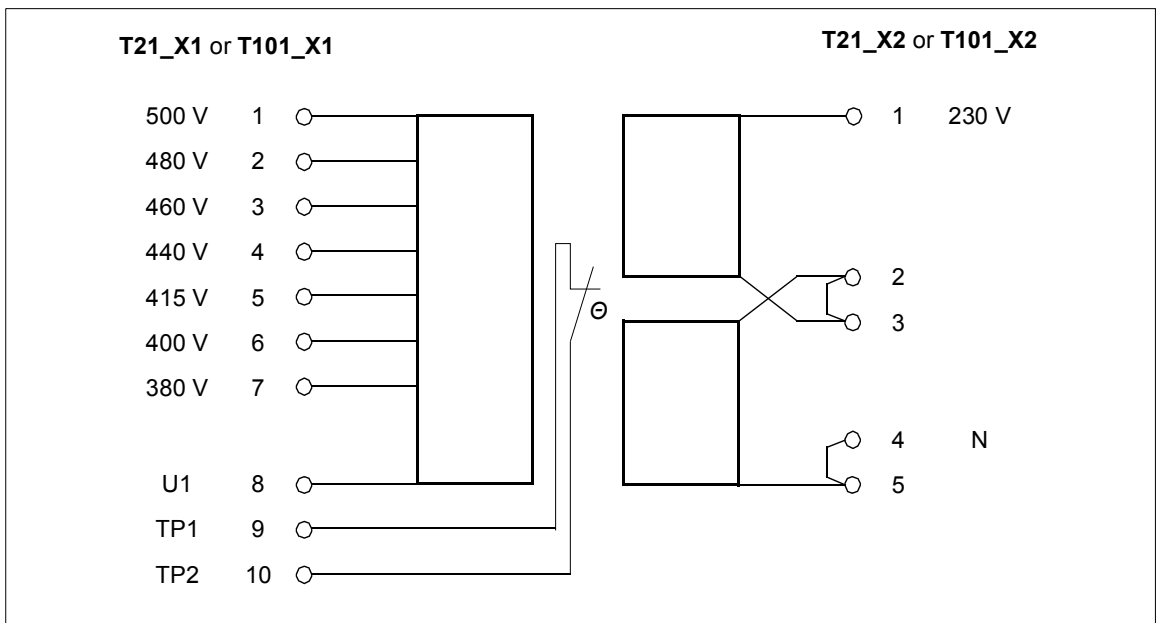

■ **T21 and T101 tap settings (690 V units)**

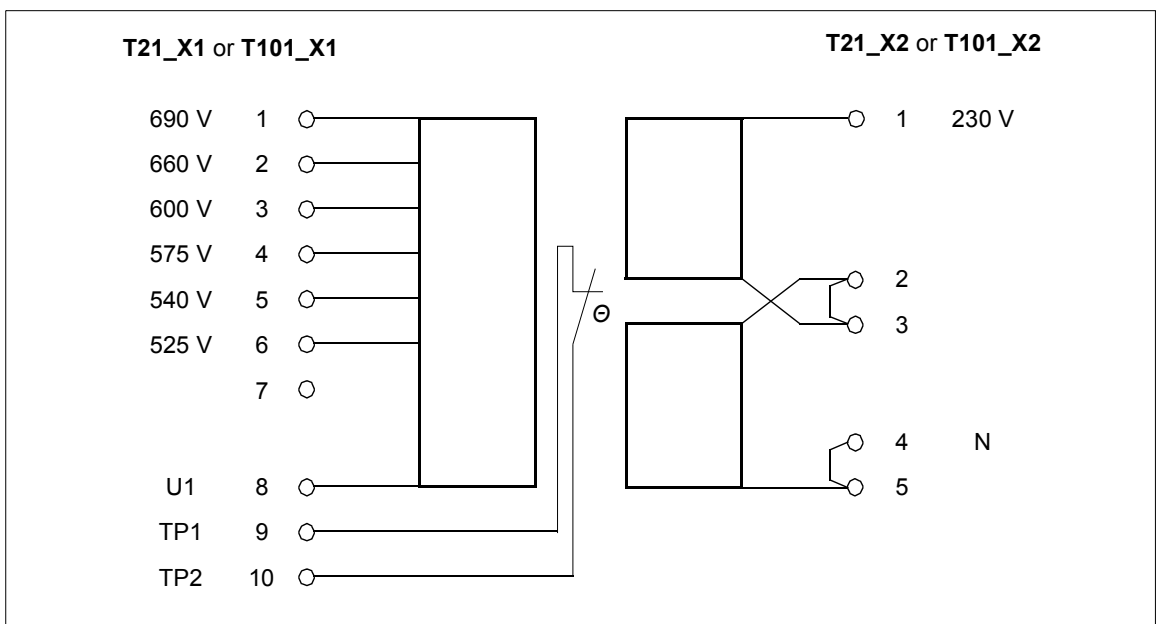

T111 tap settings

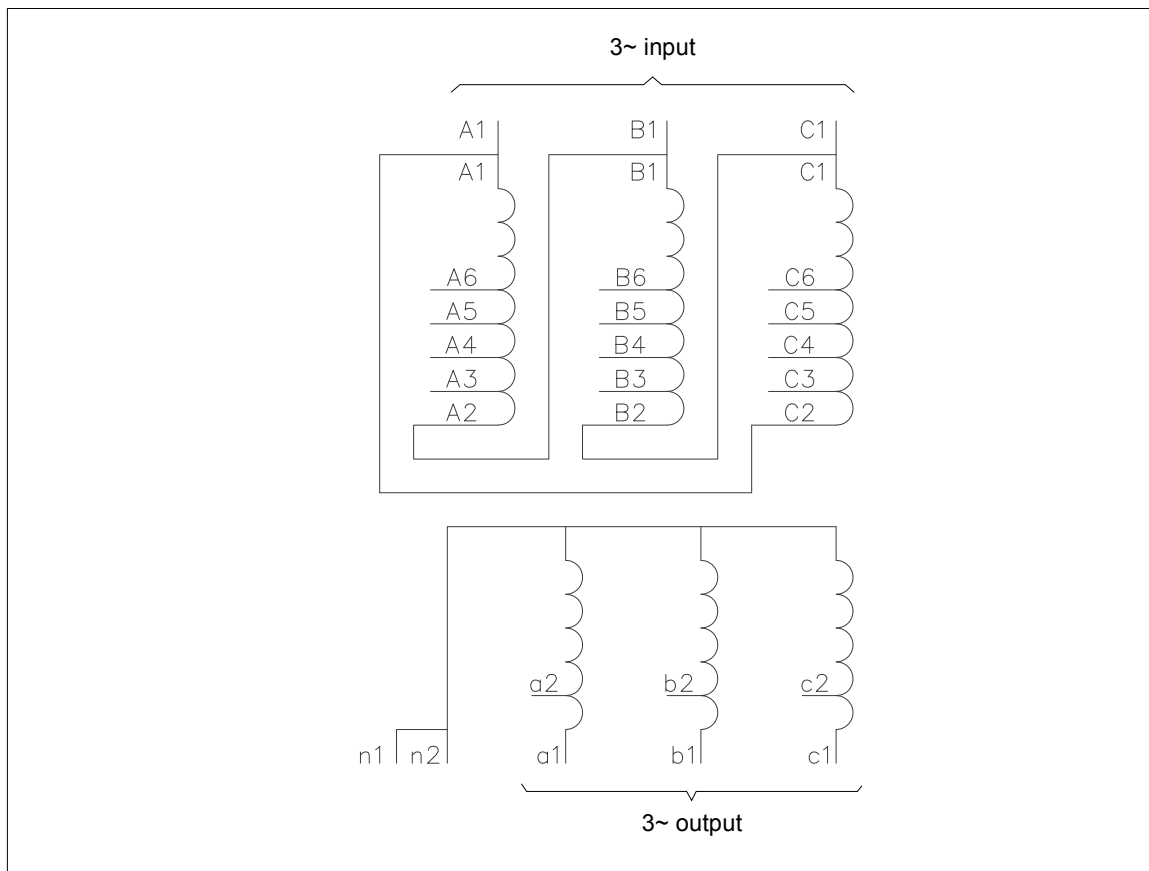

Supply voltage	3~ input			3~ output		
	Terminals	Tap settings			Terminals	
		A1-	B1-	C1-	400 V (50 Hz)	320/340 V (60 Hz)
690 V	A1, B1, C1	C2	A2	B2	a1, b1, c1	a2, b2, c2
660 V	A1, B1, C1	C2	A2	B2	a1, b1, c1	a2, b2, c2
600 V	A1, B1, C1	C3	A3	B3	a1, b1, c1	a2, b2, c2
575 V	A1, B1, C1	C3	A3	B3	a1, b1, c1	a2, b2, c2
540 V	A1, B1, C1	C4	A4	B4	a1, b1, c1	a2, b2, c2
525 V	A1, B1, C1	C4	A4	B4	a1, b1, c1	a2, b2, c2
500 V	A1, B1, C1	C4	A4	B4	a1, b1, c1	a2, b2, c2
480 V	A1, B1, C1	C5	A5	B5	a1, b1, c1	a2, b2, c2
460 V	A1, B1, C1	C5	A5	B5	a1, b1, c1	a2, b2, c2
440 V	A1, B1, C1	C5	A5	B5	a1, b1, c1	a2, b2, c2
415 V	A1, B1, C1	C6	A6	B6	a1, b1, c1	a2, b2, c2
400 V	A1, B1, C1	C6	A6	B6	a1, b1, c1	a2, b2, c2
380 V	A1, B1, C1	C6	A6	B6	a1, b1, c1	a2, b2, c2



Connecting the control cables

See chapter *Control units of the drive* (page 127) for the default I/O connections of the inverter unit (with the ACS880 primary control program). The default I/O connections can be different with some hardware options, see the circuit diagrams delivered with the drive for the actual wiring. For other control programs, see their firmware manuals.

■ Control cable connection procedure



WARNING! Obey the instructions in chapter *Safety instructions*. If you ignore them, injury or death, or damage to the equipment can occur.

1. Stop the drive (if running) and do the steps in section *Precautions before electrical work* on page 19 before you start the work.
2. Run the control cables into the auxiliary control cubicle (ACU) as described in section *Grounding the outer shields of the control cables at the cabinet lead-through* below.
3. Route the control cables as described in section *Routing the control cables inside the cabinet* (page 99).
4. Connect the control cables as described starting on page 99.

Grounding the outer shields of the control cables at the cabinet lead-through

Ground the outer shields of all control cables 360 degrees at the EMI conductive cushions as follows:

1. Loosen the tightening screws of the EMI conductive cushions and pull the cushions apart.
2. Cut adequate holes to the rubber grommets in the lead-through plate and lead the cables through the grommets and the cushions into the cabinet.
3. Strip off the cable plastic sheath above the lead-through plate just enough to ensure proper connection of the bare shield and the EMI conductive cushions.
4. Tighten the two tightening screws so that the EMI conductive cushions press tightly round the bare shield.

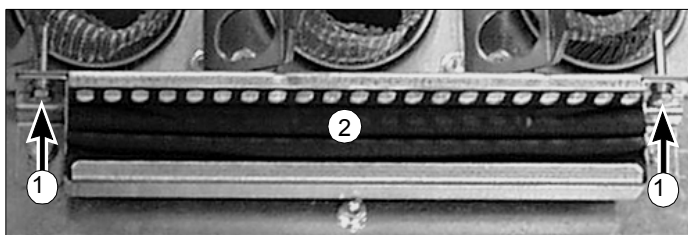

View from above

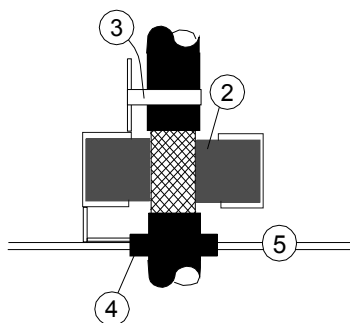

1	Tightening screw
2	EMI conductive cushion
3	Strain relief
4	Grommet
5	Lead-through plate



Note 1: Keep the shields continuous as close to the connection terminals as possible. Secure the cables mechanically at the lead-through strain relief.

Note 2: If the outer surface of the shield is non-conductive:

- Cut the shield at the midpoint of the bare part. Be careful not to cut the conductors or the grounding wire (if present).
- Turn the shield inside out to expose its conductive surface.
- Cover the turned shield and the stripped cable with copper foil to keep the shielding continuous.

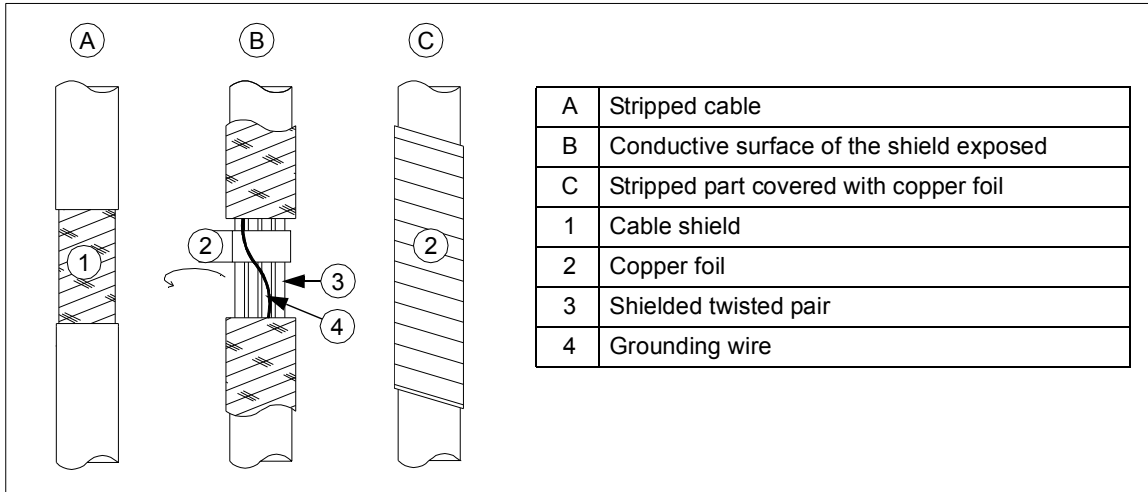

Note for top entry of cables: When each cable has its own rubber grommet, sufficient IP and EMC protection can be achieved. However, if very many control cables come to one cabinet, plan the installation beforehand as follows:

1. Make a list of the cables coming to the cabinet.
2. Sort the cables going to the left into one group and the cables going to the right into another group to avoid unnecessary crossing of cables inside the cabinet.
3. Sort the cables in each group according to size.
4. Group the cables for each grommet as follows ensuring that each cable has a proper contact to the cushions on both sides.

Cable diameter in mm	Max. number of cables per grommet
≤ 13	4
≤ 17	3
< 25	2
≥ 25	1



5. Arrange the bunches according to size from thickest to the thinnest between the EMI conductive cushions.

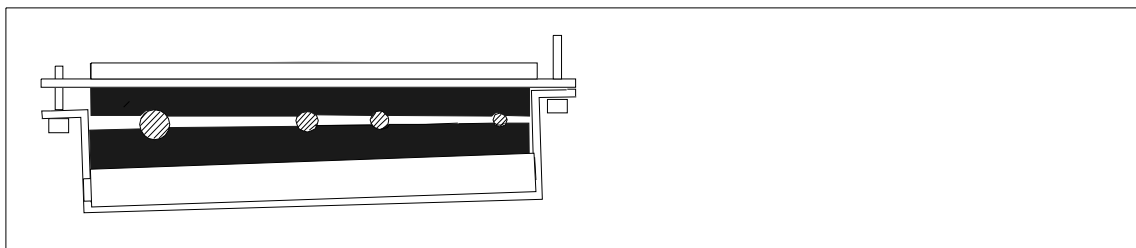

6. If more than one cable go through a grommet, seal the grommet by applying Loctite 5221 (catalogue number 25551) inside the grommet.

Routing the control cables inside the cabinet

Use the existing trunking in the cabinet wherever possible. Use sleeving if cables are laid against sharp edges. When running cables to or from the swing-out frame, leave enough slack at the hinge to allow the frame to open fully.

Connecting to the inverter control unit (A41)

Connect the conductors to the appropriate terminals (see page [127](#)) of the control unit or terminal block X504 (option +L504).

Connect the inner twisted pair shields and all separate grounding wires to the grounding clamps below the control unit.

The drawing below represents a drive with additional I/O terminal block (option +L504). Without the block, the grounding is made the same way.

Notes:

- Do not ground the outer shield of the cable here since it is grounded at the lead-through.
- Keep any signal wire pairs twisted as close to the terminals as possible. Twisting the wire with its return wire reduces disturbances caused by inductive coupling.



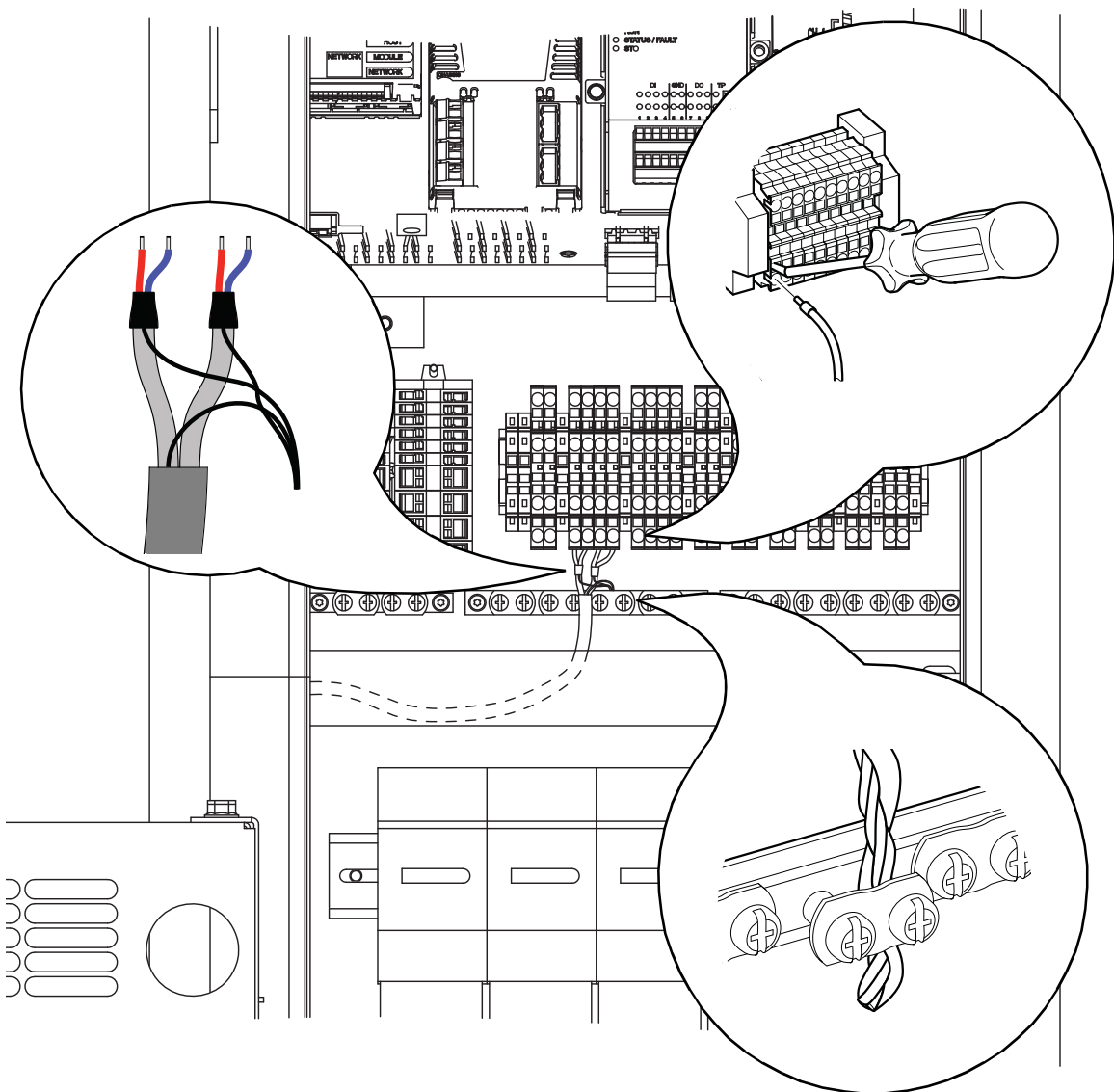

At the other end of the cable, leave the shields unconnected or ground them indirectly via a high-frequency capacitor with a few nanofarads, eg. 3.3 nF / 630 V. The shield can also be grounded directly at both ends if they are in the same ground line with no significant voltage drop between the end points.

Connecting a 230/115 V AC auxiliary voltage supply (UPS, option +G307)

Wire the external control voltage to terminal block X307 at the back side of the mounting plate as shown below.

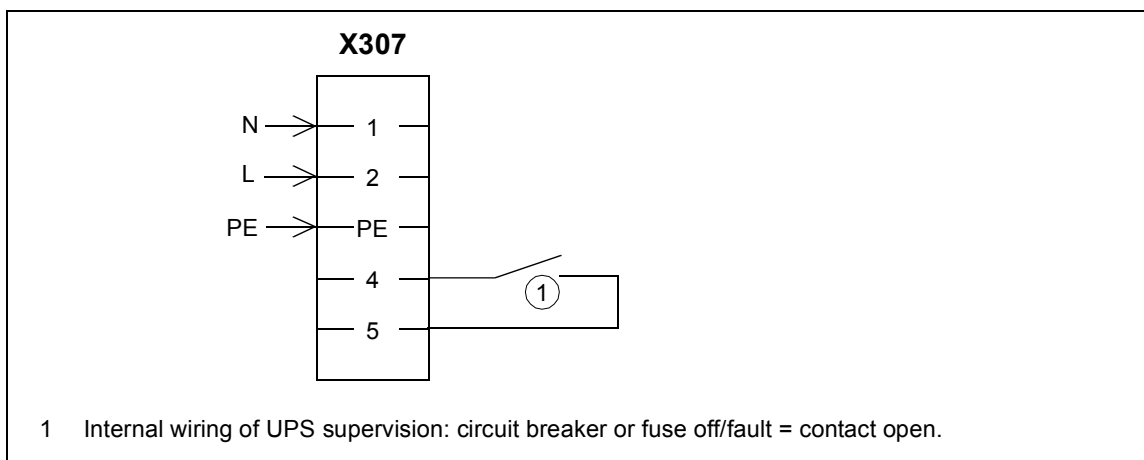
**Connecting the emergency stop push buttons (options +Q951, +Q952, +Q963, +Q964, +Q978, +Q979)**

Connect external emergency stop push buttons according to the circuit diagrams delivered with the drive.

Wiring the starter for auxiliary motor fan (options +M602...+M610)

Connect the power supply wires for the auxiliary motor fan to terminal blocks X601...X605 according to the circuit diagrams delivered with the drive.



Wiring the thermistor relay(s) (options +L505 and +2L505)

The external wiring of option +2L505 (two thermistor relays) is shown below. For example, one relay can be used to monitor the motor windings, the other to monitor the bearings. The maximum contact load capacity is 250 V AC 10 A. For the actual wiring, see the circuit diagram delivered with the drive.

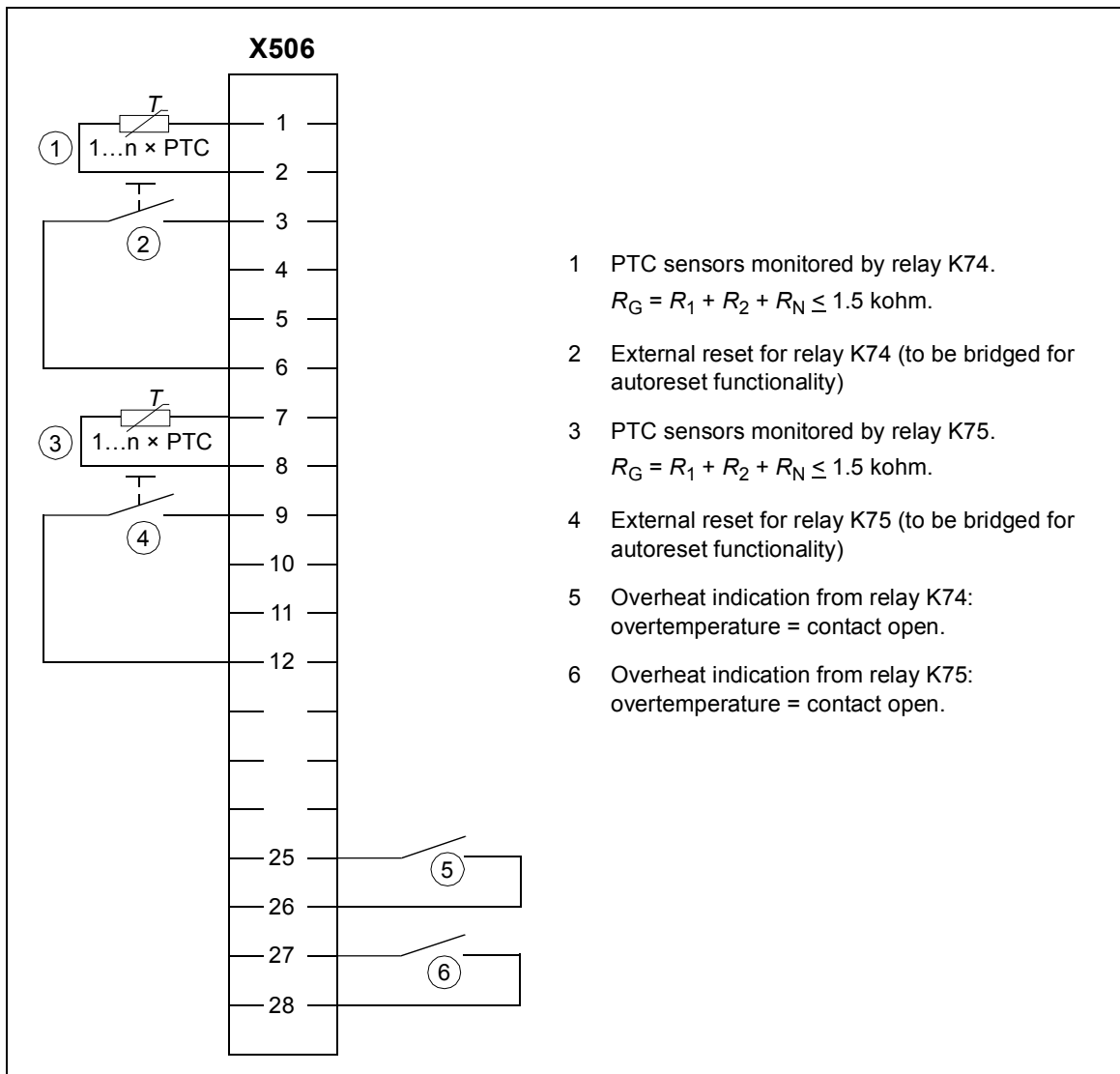

Wiring the Pt100 relays (options +2L506, +3L506, +5L506 and +8L506)

External wiring of eight Pt100 sensor modules is shown below. Contact load capacity 250 V AC 10 A. For the actual wiring, see the circuit diagram delivered with the drive.

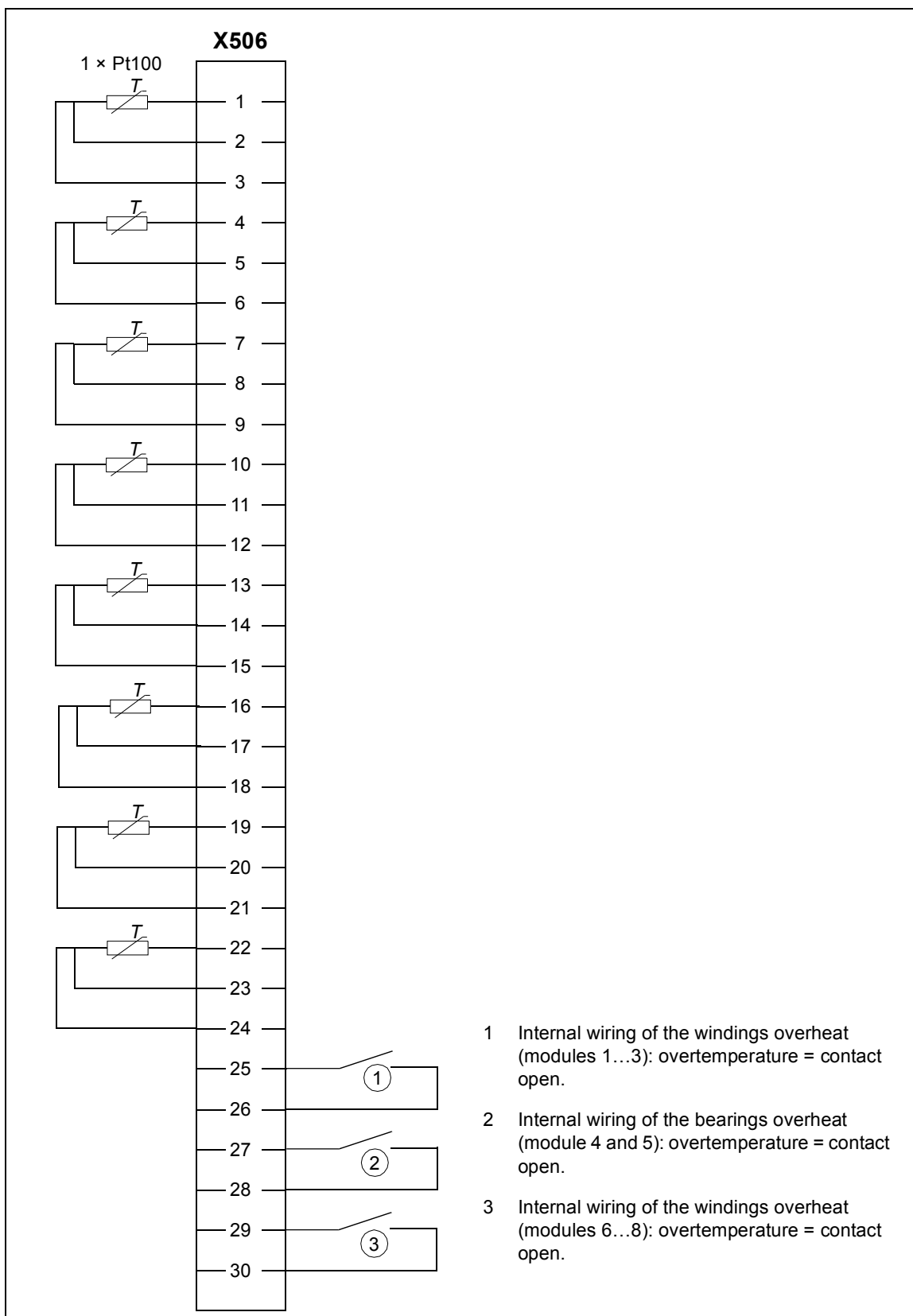

Powering the heating and lighting equipment (options +G300, +G301 and +G313)

See the circuit diagrams delivered with drive.

Connect the external power supply wires for the cabinet heater and lighting to terminal block X300 at the back of the mounting plate.

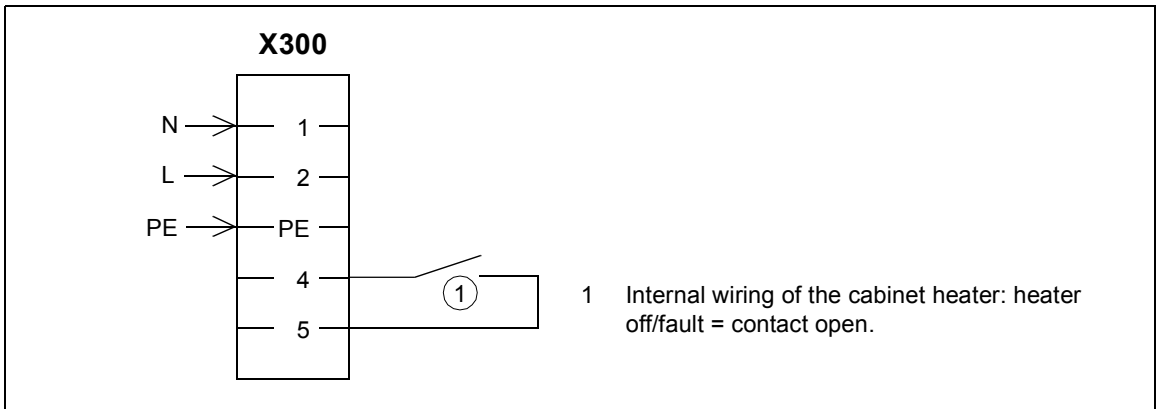

Connect the motor heater wiring to terminal block X313 as shown below. Maximum external power supply 16 A.

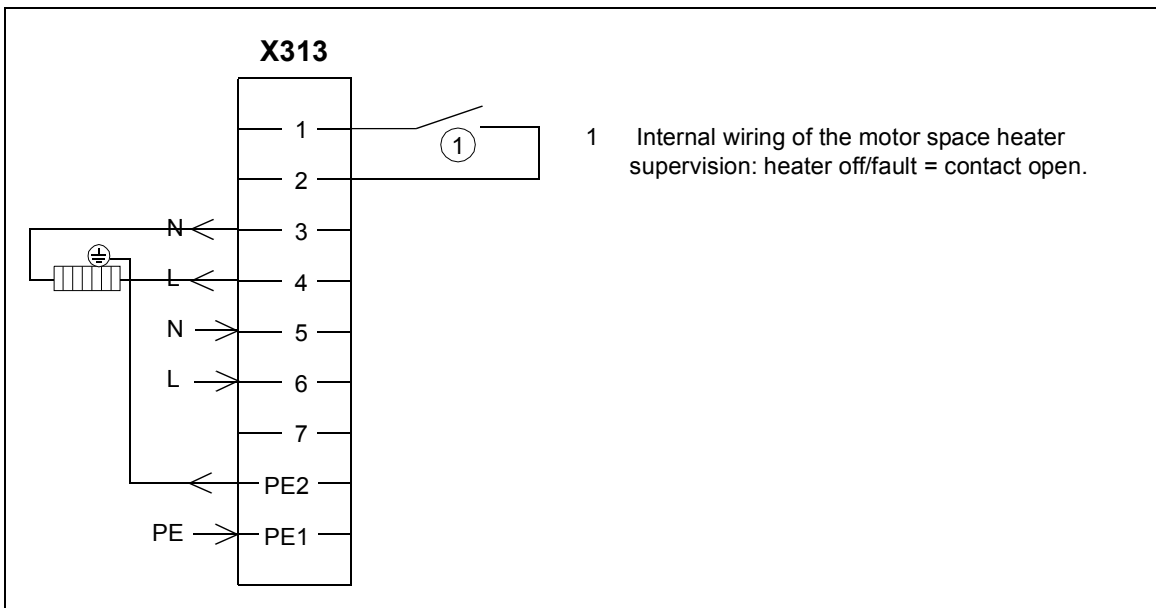

Wiring ground fault monitoring for IT ungrounded systems (option +Q954)

We recommend to connect Alarm 1 for drive tripping and Alarm 2 for alarm signals in order to avoid unnecessary trippings due to the ground fault monitor self testing with Alarm 2.

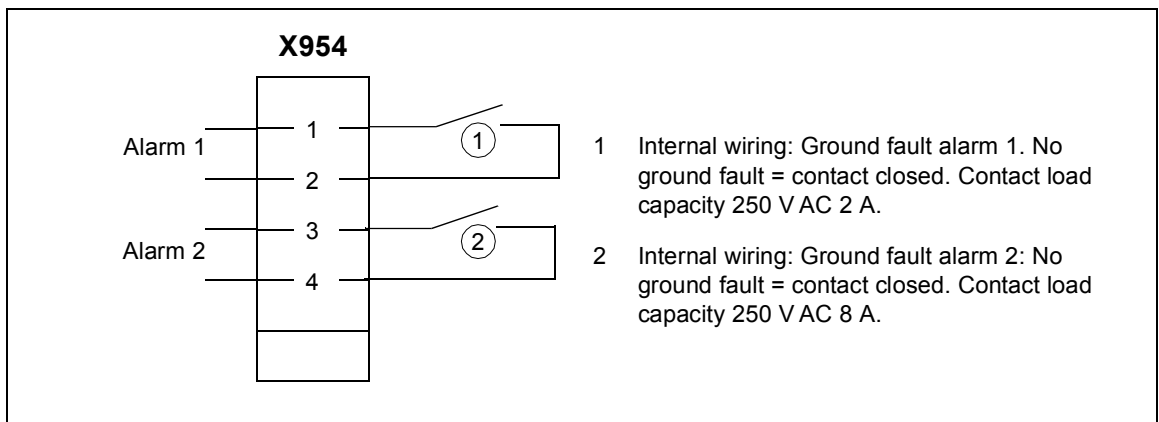

Connecting the motor cables (units without common motor terminal cubicle or sine output filter)

On units without a common motor terminal cubicle or a sine output filter, the motor cables connect to busbars located behind the inverter module(s). The location and dimensions of the busbars are visible in the dimensional drawings delivered with the drive, as well as the example drawings presented in this manual (starting on page 241).

To allow the most room for the work, the modules can be removed completely from the cabinet. For instructions, see section [Removing the inverter module\(s\)](#) (page 108).

Especially in the case of multiple inverter modules in the same cubicle, you can consider only removing the fan carriage of each module. This is faster than removing the entire module, but allows less room for the connecting work. For instructions, go to section [Removing and reinstalling the fan carriage of an inverter module](#) (page 112).

If the drive is equipped with a common motor terminal cubicle (option +H359) or a sine output filter (option +E206), follow the procedure starting on page 117.

■ Connection diagram (without option +H366)

All parallel-connected inverter modules are to be cabled separately to the motor. 360° earthing is to be used at cable lead-throughs.

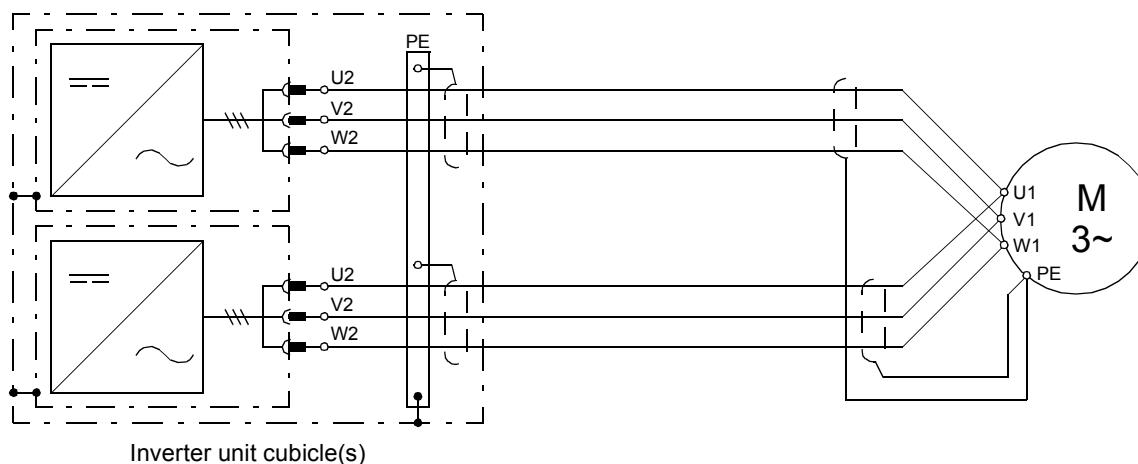

The recommended cable types are given in chapter [Guidelines for planning the electrical installation](#).



WARNING! The cabling from all inverter modules to the motor must be physically identical considering cable type, cross-sectional area, and length.

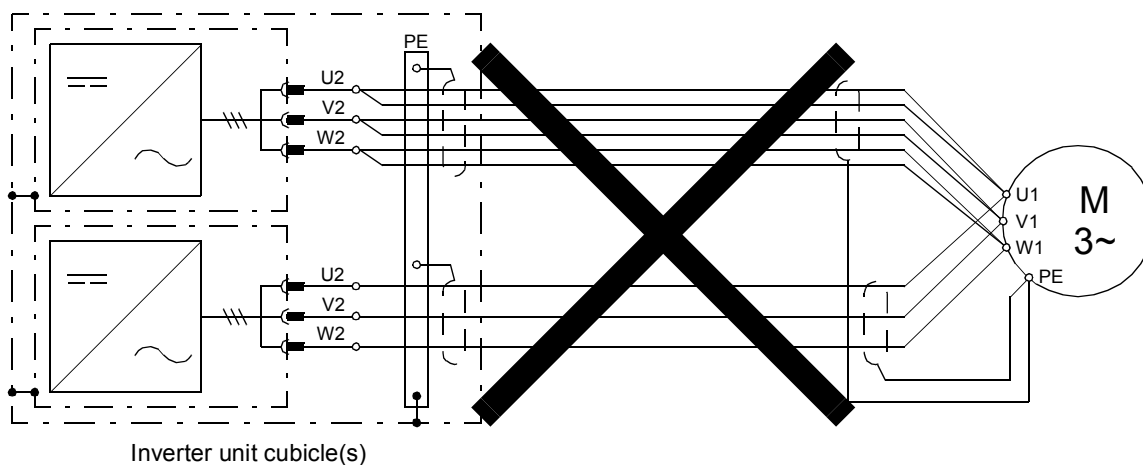

■ **Connection diagram (with option +H366)**

With option +H366, the output busbars of the inverter modules **within the same cubicle** are connected by bridging busbars. The bridging balances the motor current between the modules, which allows more cabling options. For example, it is possible to use a number of cables that could not otherwise be evenly distributed between the inverter modules.

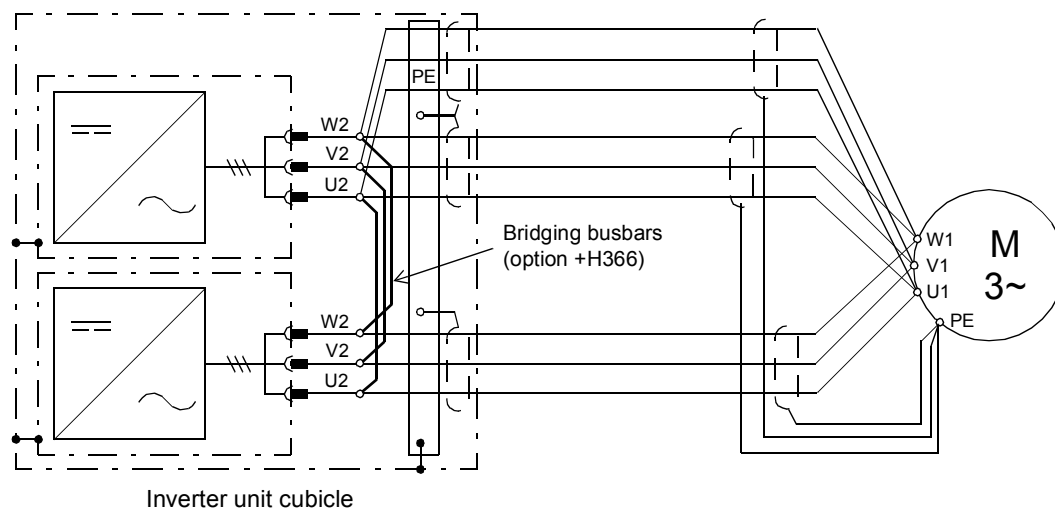

The recommended cable types are given in chapter [Guidelines for planning the electrical installation](#).



WARNING! The bridging can carry the nominal output of one inverter module. In case of three parallel modules, ensure that the load capacity of the bridging is not exceeded. For example, if the cabling connects to the output busbars at one module only, use the module in the middle.

Note: The +H366 option only interconnects the outputs of inverter modules within the same cubicle, not modules installed in different cubicles. Therefore, when the drive has



multiple inverter cubicles (ie. two cubicles of two modules each), make sure that the motor cabling is identical for both cubicles.

■ Procedure

Removing the inverter module(s)

To allow more room for cabling work, the inverter modules can be removed completely instead of only the fan carriages.

Refer to the drawings below.



WARNING! Obey the instructions in chapter [Safety instructions](#). If you ignore them, injury or death, or damage to the equipment can occur.

1. Do the steps in section [Precautions before electrical work](#) on page 19 before you start the work.
 2. Open the inverter module cubicle door.
 3. Remove the shroud at the top of the cubicle.
 4. Detach the terminal block [X50] at the top of the module.
 5. Detach the DC busbars from the module. Make note of the order and position of the screws and washers.
 6. Detach the wiring connected to the terminals on the front of the module (including fiber optic cabling). Move the disconnected wiring aside.
 7. Attach the module extraction/installation ramp (included) to the base of the cabinet so that the tabs on the mounting bracket enter the slots on the ramp.
-



WARNING! Do not use the ramp included in the drive delivery with plinth heights over 50 mm.

8. Remove the two screws at the bottom front of the module.
-



WARNING! Before you proceed, make sure the cabinet is level, or chock the wheels of the module.

9. Remove the two screws at the top front of the module.
10. Pull the module carefully out along the ramp. While pulling on the handle with your right hand, keep a constant pressure with one foot on the base of the module to prevent the module from falling on its back.
11. Move the module into a safe location outside the immediate work area and make sure it cannot topple over. Chock the wheels of the module if the floor is not completely level.
12. Repeat the procedure for the other inverter modules.

Proceed to [Connecting the motor cables](#) (page 114).

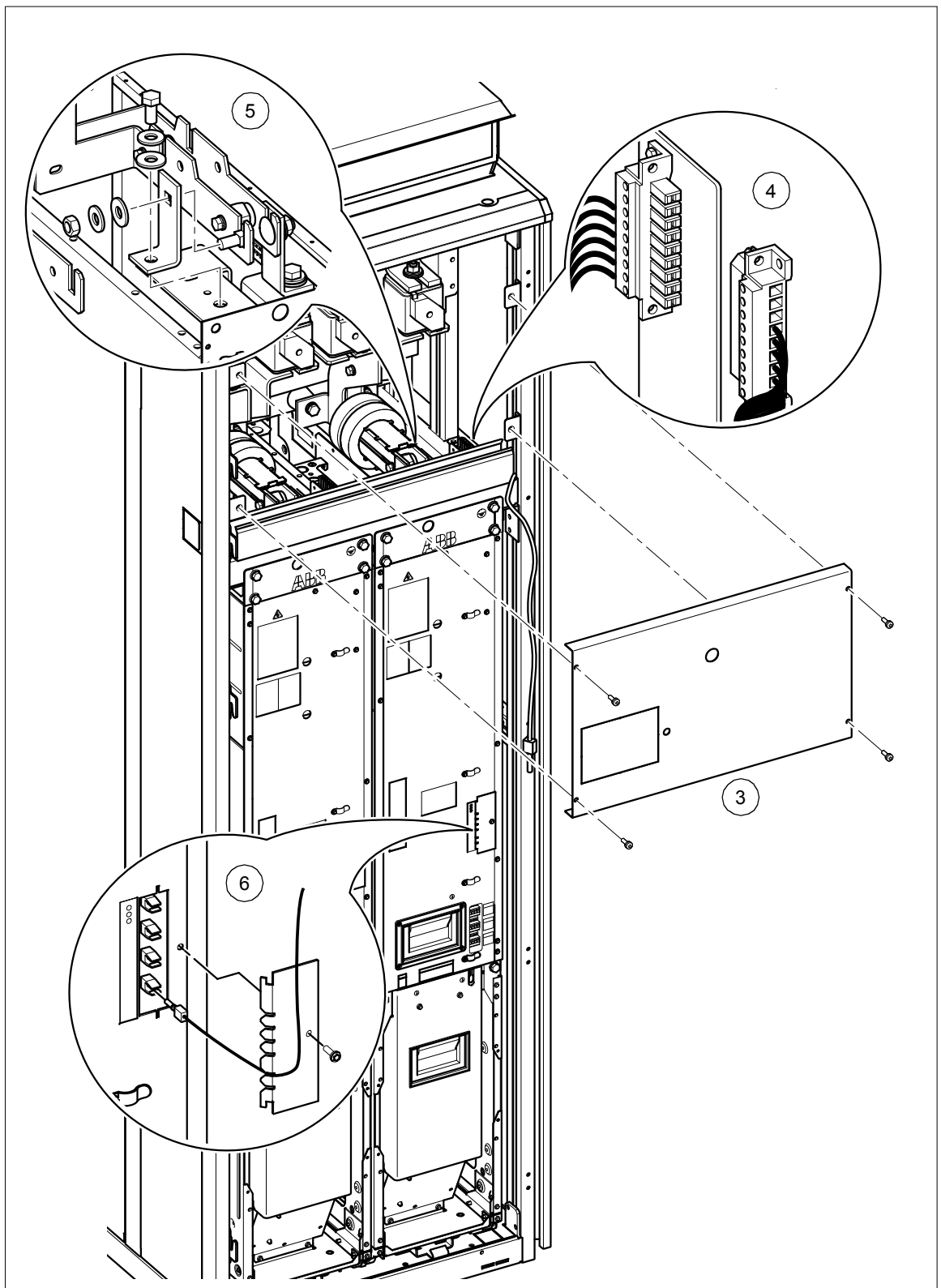

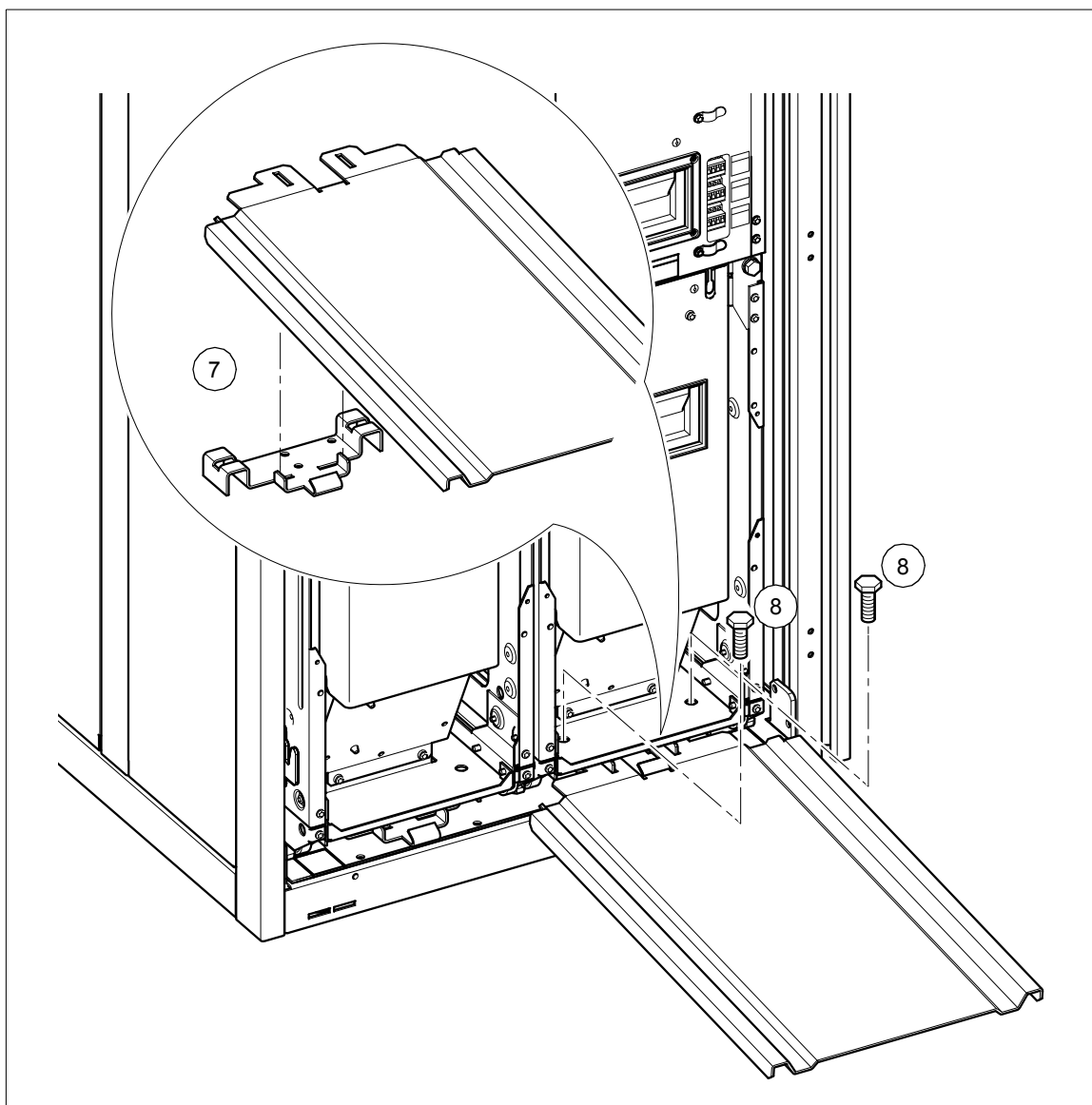

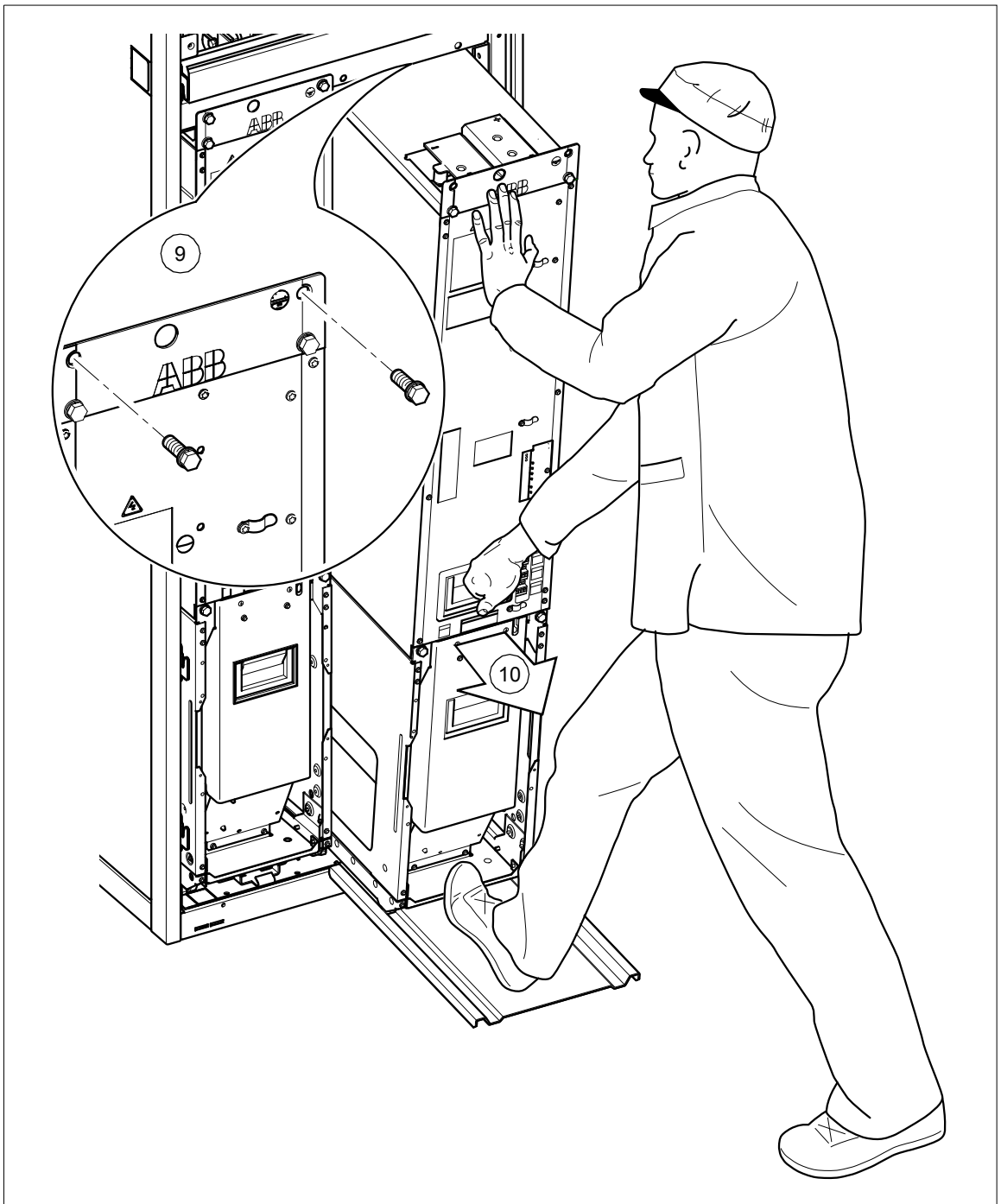

Removing and reinstalling the fan carriage of an inverter module

Refer to the drawings below.



WARNING! Obey the instructions in chapter [Safety instructions](#). If you ignore them, injury or death, or damage to the equipment can occur.

1. Do the steps in section [Precautions before electrical work](#) on page [19](#) before you start the work.
 2. Open the inverter module cubicle door.
 3. Remove the screws holding the front cover plate. Lift the cover plate somewhat to release it.
 4. Disconnect the wiring at the top of the fan carriage.
 5. Remove the two screws at the bottom of the fan carriage.
-



WARNING! Before you proceed, make sure the two screws holding the top of the inverter module are in place.

6. Remove the two screws at the top of the fan carriage.
7. Pull the fan carriage out.
8. Repeat the procedure for other fan carriages in the same cubicle.

Proceed to [Connecting the motor cables](#) (page [114](#)).



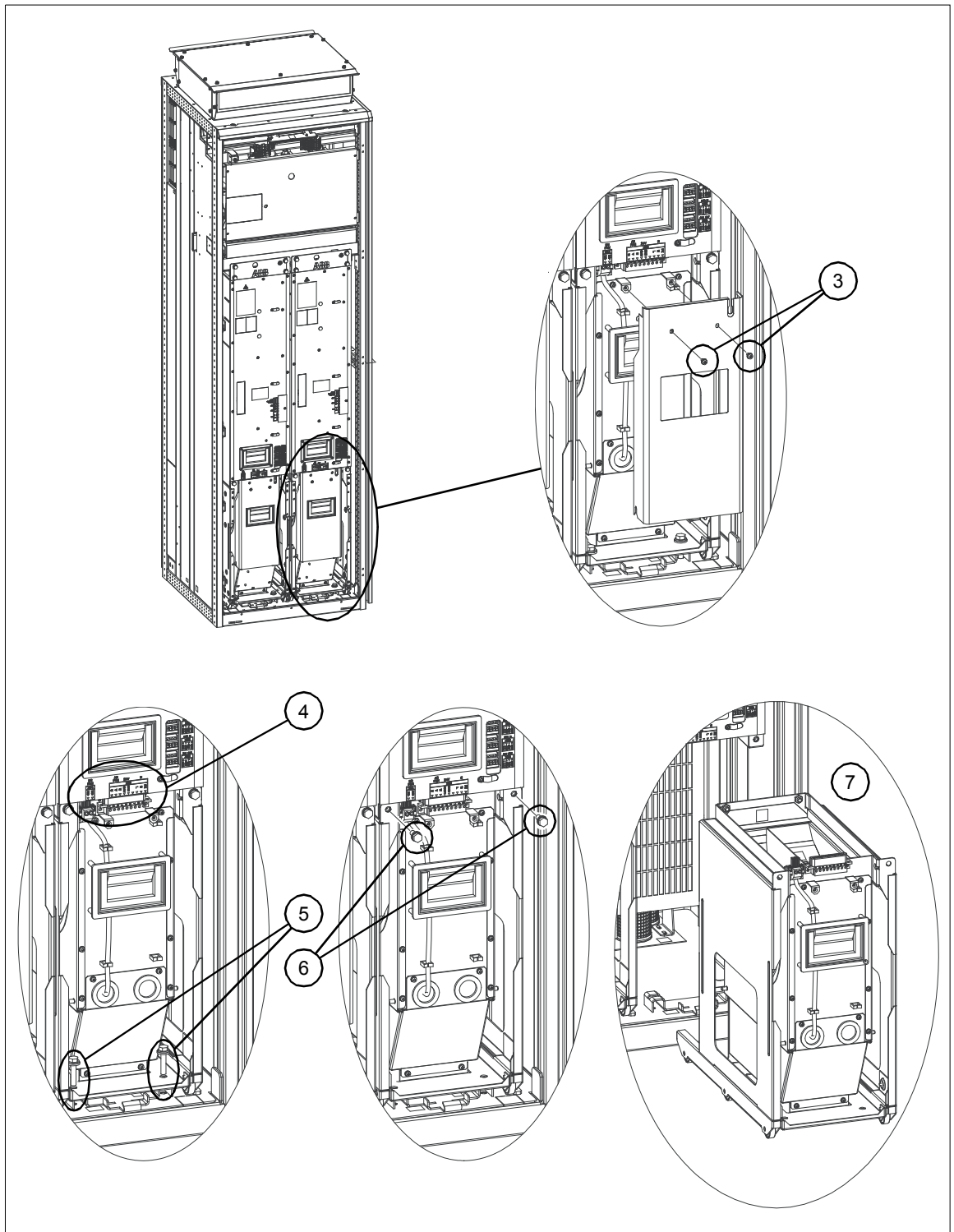

Connecting the motor cables

Refer to the drawings below.



WARNING! Obey the instructions in chapter [Safety instructions](#). If you ignore them, injury or death, or damage to the equipment can occur.

1. Do the steps in section [Precautions before electrical work](#) on page 19 before you start the work.
 2. Remove the shroud in front of the output busbars.
 3. For 360° grounding of the shield at the cable entry, remove the outer jacket of each cable where they pass through the cable entry (a).
 4. Cut the cable to suitable length and strip the ends of the individual conductors. Twist the shield strands together to form a separate conductor and wrap it with tape.
 5. Crimp suitable lug terminals onto the phase conductors and the ground conductor. The dimensions of the output busbars are shown in chapter [Technical data](#).
 6. Connect the phase conductors of the motor cable to the U2, V2 and W2 terminals. You can temporarily remove the plastic insulators (b) between the busbars to make the connecting work easier.
-



WARNING! The plastic insulators (b) between the busbars must be in place when the inverter is powered.

7. Connect the shield (and any grounding conductors) of the cable to the PE busbar close to the cable entries.
8. Secure the cable mechanically.
9. Repeat the procedure for each motor cable.
10. Refit the shroud removed earlier.
11. At the motor, connect the cables according to instructions from the motor manufacturer. Pay special attention to the phase order. For minimum radio-frequency interference, ground the cable shield 360 degrees at the cable entry of the motor terminal box, or ground the cable by twisting the shield so that the flattened shield is wider than 1/5 of its length.



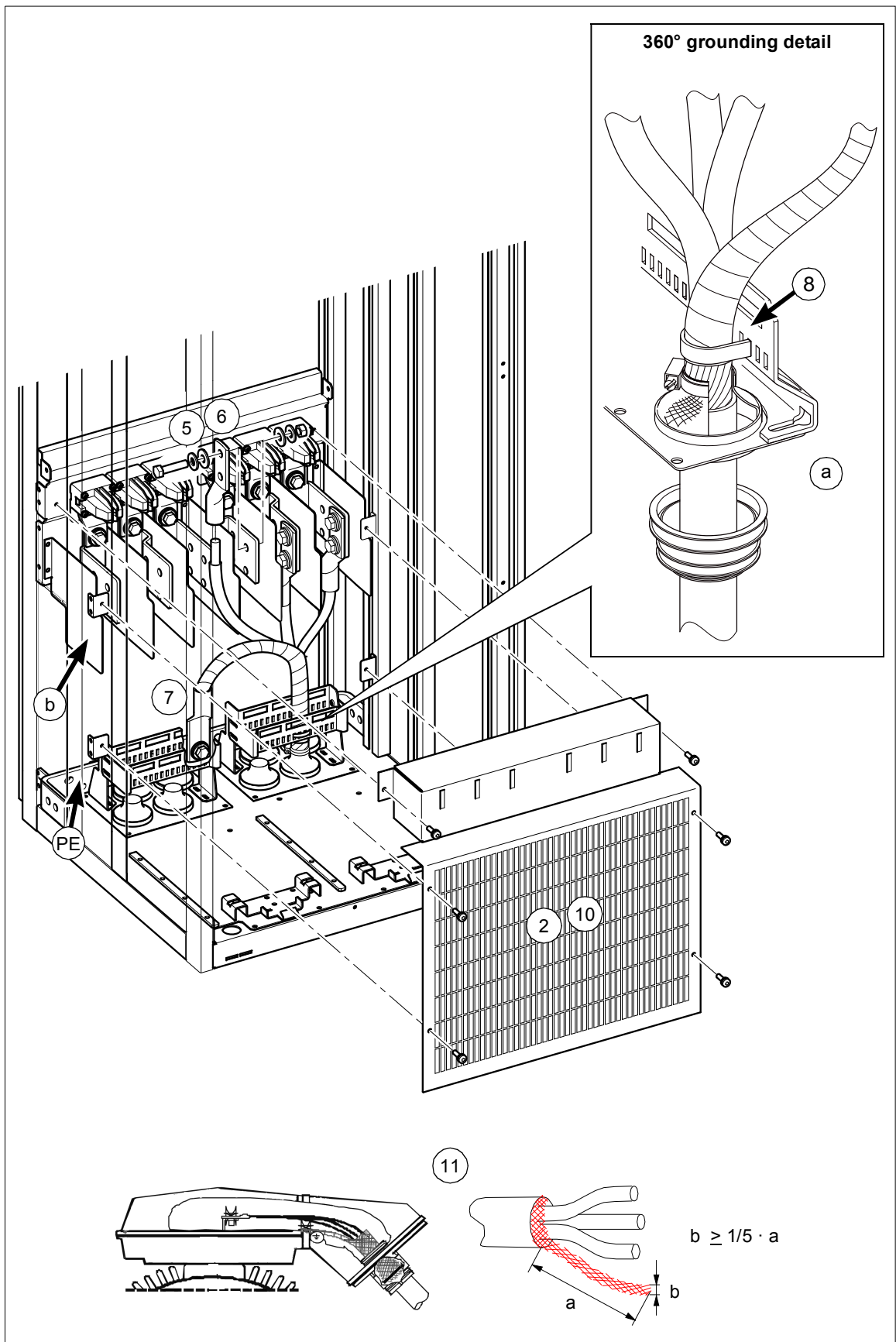

Re-installing the fan carriage of an inverter module

(If the inverter module was removed completely instead of only the fan carriage, proceed to section [Re-inserting the inverter module into the cubicle](#) below.)

The re-installation of the fan carriage is the removal procedure in reverse. See section [Removing and reinstalling the fan carriage of an inverter module](#) (page 112).

Re-inserting the inverter module into the cubicle



WARNING! Obey the instructions in chapter [Safety instructions](#). If you ignore them, injury or death, or damage to the equipment can occur.

1. Make sure there are no tools, debris or any other foreign objects in the cubicle.
2. If not already in place, attach the module extraction/installation ramp (included) to the base of the cabinet so that the tabs on the mounting bracket enter the slots on the ramp.
3. Push the module up the ramp and back into the cubicle.
 - **Keep your fingers away from the edge of the module front plate to avoid pinching.**
 - **Keep a constant pressure with one foot on the base of the module to prevent the module from falling on its back.**
4. Secure the top front of the module with two screws. Tighten to 22 N·m (16 lbf·ft).
5. Secure the bottom front of the module with two screws. Tighten to 22 N·m (16 lbf·ft).
6. Remove the ramp.
7. Attach the DC busbars to the module. Tighten to 70 N·m (52 lbf·ft).
8. Reconnect terminal block [X50] at the top of the module.
9. Reconnect the wiring and fiber optic cables to the terminals on the front of the module.
10. Repeat the procedure for the other inverter modules.
11. Reinstall the shroud near the top of the cubicle.



Connecting the motor cables (units with common motor terminal cubicle or sine output filter)

■ Output busbars

If the drive is equipped with option +H359, the motor cables connect to a common motor terminal cubicle. Similarly, if the drive is equipped with option +E206 (sine output filter), the motor cables connect to the output busbars in the sine filter cubicle.

The location and dimensions of the busbars for either case are visible in the dimensional drawings delivered with the drive, as well as the drawings starting on page 245.

■ Connection diagram

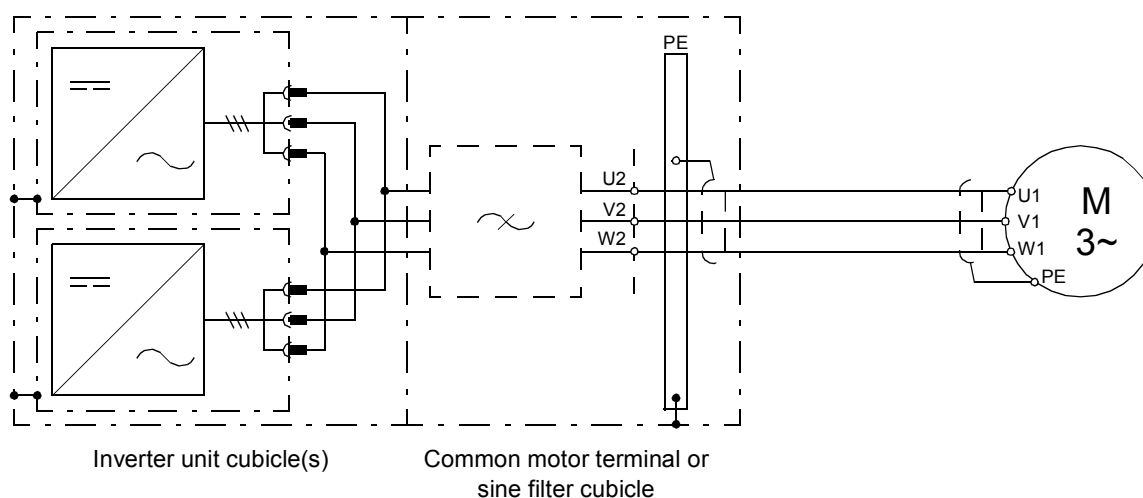

The recommended cable types are given in chapter [Guidelines for planning the electrical installation](#).

■ Procedure



WARNING! Obey the instructions in chapter [Safety instructions](#). If you ignore them, injury or death, or damage to the equipment can occur.

1. Do the steps in section [Precautions before electrical work](#) on page 19 before you start the work.
2. Open the door of the common motor terminal or sine filter cubicle and remove the shrouding.



3. Lead the cables into the cubicle. Make the 360° earthing arrangement at the cable entry as shown.

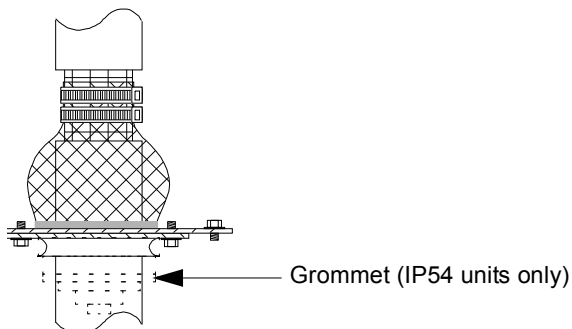

4. Cut the cables to suitable length. Strip the cables and conductors.
5. Twist the cable screens into bundles and connect the bundles to the PE busbar in the cubicle.
6. Connect any separate ground conductors/cables to the PE busbar in the cubicle.
7. Connect the phase conductors to the output terminals. Use the torques specified under [Tightening torques](#) (page 199).
8. Refit any shrouding removed earlier and close the cubicle doors.
9. At the motor, connect the cables according to instructions from the motor manufacturer. Pay special attention to the phase order. For minimum radio-frequency interference, ground the cable shield 360 degrees at the lead-through of the motor terminal box, or ground the cable by twisting the shield so that the flattened shield is wider than 1/5 of its length.

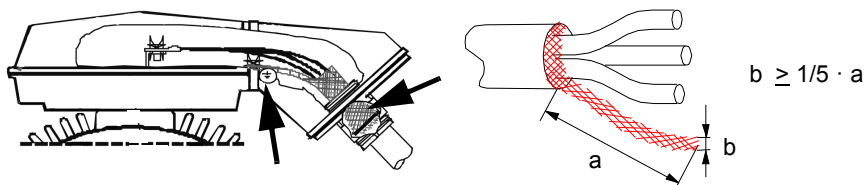

Connecting an external brake resistor assembly

See section [Electrical installation of custom brake resistors](#) (page 267).

For the location of the terminals, refer to the dimension drawings delivered with the unit or the dimension drawing examples in chapter [Dimensions](#).

Connecting the input power cables

■ Connection diagram, 6-pulse units

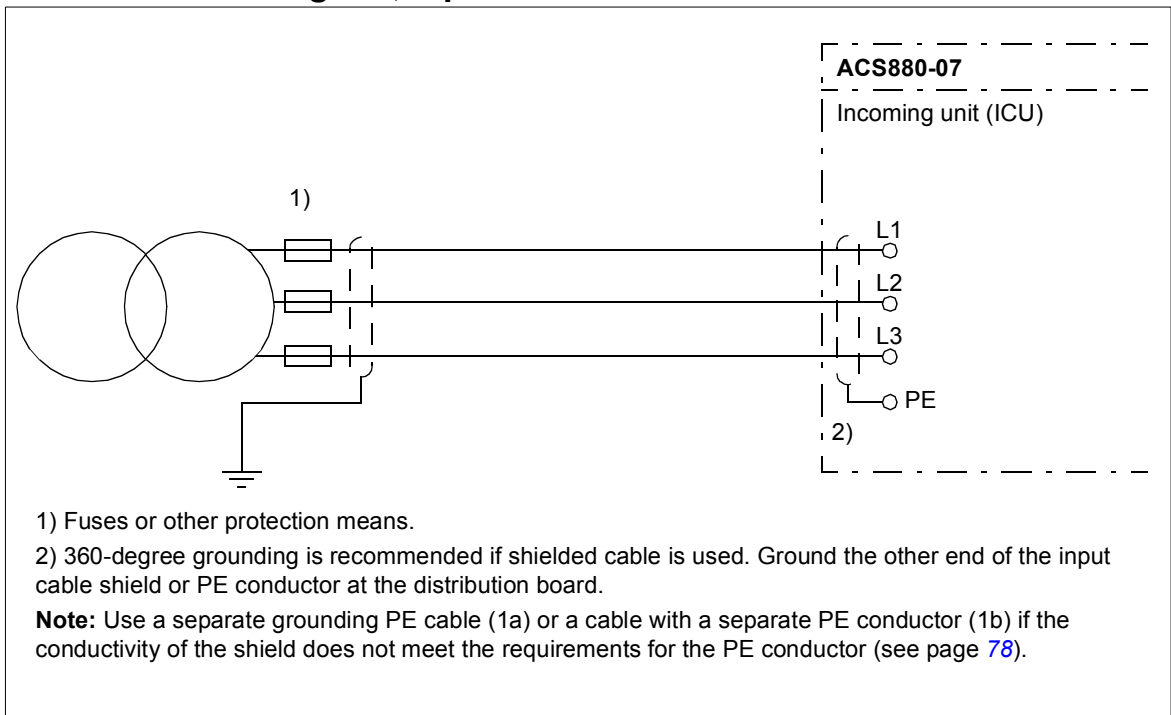

■ Connection diagram, 12-pulse units

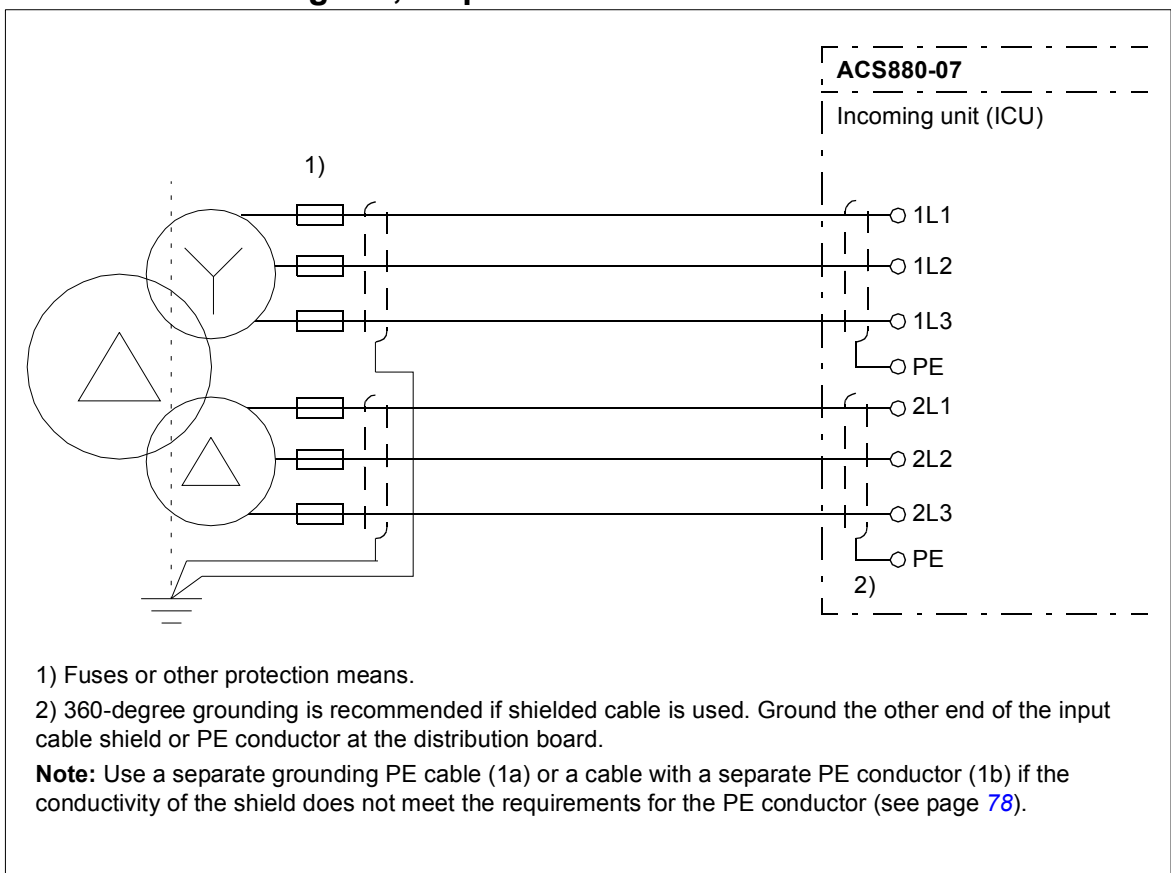

Layout of the input cable connection terminals and lead-throughs

The location and dimensions of the busbars are visible in the dimensional drawings delivered with the drive, as well as the drawings starting on page 235.

Connection procedure



WARNING! Obey the instructions in chapter [Safety instructions](#). If you ignore them, injury or death, or damage to the equipment can occur.

1. Do the steps in section [Precautions before electrical work](#) on page 19 before you start the work.
2. Open the door of the incoming cubicle (ICU).
3. Remove the shrouding covering the input terminals.
4. Peel off 3 to 5 cm of the outer insulation of the cables above the lead-through plate for 360° high-frequency grounding.
5. Prepare the ends of the cables.

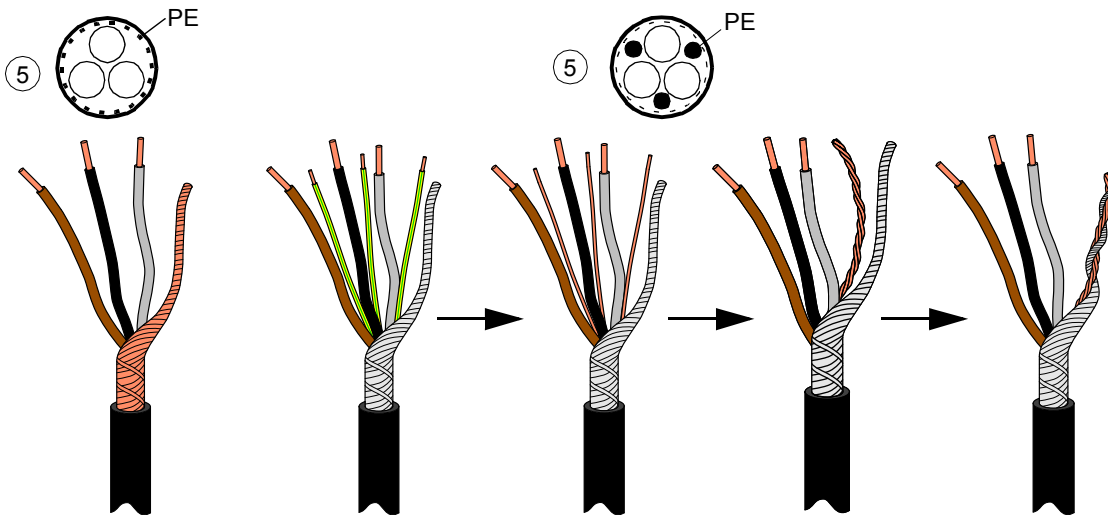

6. If fire insulation is used, make an opening in the mineral wool sheet according to the diameter of the cable.
7. For IP22, IP42 drives: Slide the cables through the lead-throughs with the conductive sleeves.
8. For IP54 drives: Remove the rubber grommets from the lead-through plate for the cables to be connected. Cut adequate holes into the rubber grommets. Slide the grommets onto the cables. Slide the cables through the lead-throughs with the conductive sleeves and attach the grommets to the holes.
9. Fasten the conductive sleeves to the cable shields with cable ties.
10. Seal the slot between the cable and mineral wool sheet (if used) with sealing compound (eg, CSD-F, ABB brand name DXXT-11, code 35080082).
11. Tie up the unused conductive sleeves with cable ties.
12. Connect the twisted shields of the cables to the PE busbar of the cabinet.
13. Connect the phase conductors of the input cable to the L1, L2 and L3 terminals. (With 12-pulse connection, the terminals are 1L1, 1L2 and 1L3 for one 6-pulse supply line,

2L1, 2L2 and 2L3 for the other.) Tighten the screws to the torque given under [Tightening torques](#) (page 199).

14. Reinstall the shrouding removed earlier.
15. Close the door.

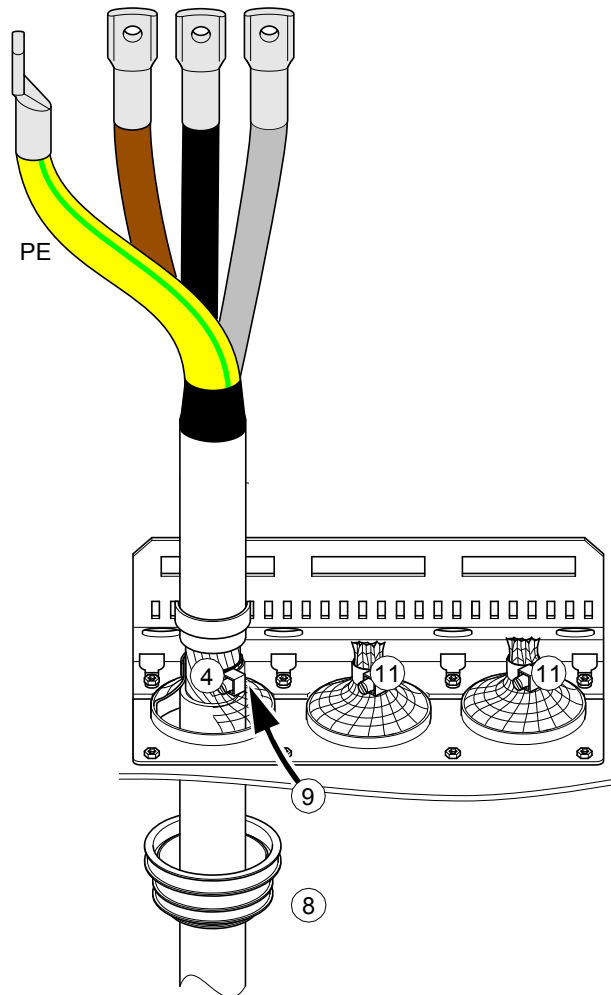

Connecting a PC

A PC (with eg. the Drive composer PC tool) can be connected to the inverter unit as follows:

1. Connect an ACS-AP-I control panel to the inverter control unit either by using an Ethernet (eg. CAT5E) networking cable, or by inserting the panel into the panel holder (if present).



WARNING! Do not connect the PC directly to the control panel connector of the inverter unit as this can cause damage.

2. Remove the USB connector cover on the front of the control panel.
3. Connect an USB cable (Type A to Type Mini-B) between the USB connector on the control panel (3a) and a free USB port on the PC (3b).
4. The panel will display an indication whenever the connection is active.

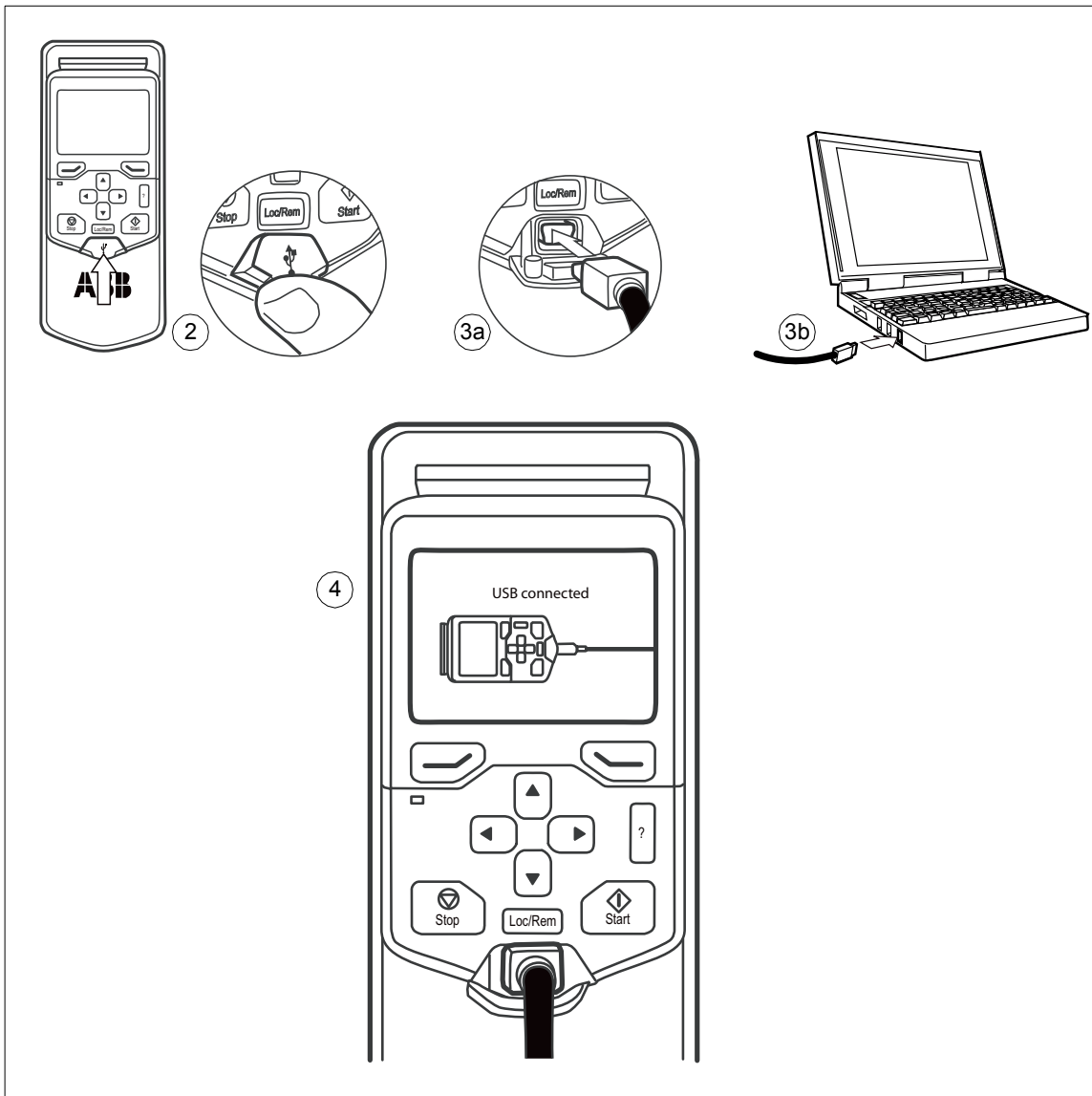

5. See the documentation of the PC tool for setup instructions.

Panel bus (Control of several units from one control panel)

One control panel (or PC) can be used to control several supply or inverter units by constructing a panel bus. A control panel mounting platform or an FDPI-02 module is required. For further information, see *FDPI-02 diagnostics and panel interface user's manual* (3AUA0000113618 [English]).

Note: The ACS880-07 has an internal panel bus connecting both the supply control unit (A51) and the inverter control unit (A41) to the panel. Unless other units are to be connected to the panel bus, go to step 4.

1. Connect the panel to one inverter unit using an Ethernet (eg. CAT5E) cable.
 - Use Menu – Settings – Edit texts – Drive to give a descriptive name to the unit
 - Use parameter 49.01 to assign the unit with a unique node ID number
 - Set other parameters in group 49 if necessary
 - Use parameter 49.06 to validate any changes.

Repeat the above for each unit.

2. With the panel connected to one inverter unit, link the inverter units together using Ethernet cables. (Each panel platform has two connectors.)
3. In the last unit, switch bus termination on. With a panel platform, move the terminating switch into the outer position. (With an FDPI-02 module, move termination switch S2 into the TERMINATED position.) Termination should be off on all other units.
4. On the control panel, switch on the panel bus functionality (Options – Select drive – Panel bus). The unit to be controlled can now be selected from the list under Options – Select drive.
5. If a PC is connected to the control panel, the units on the panel bus are automatically displayed in the Drive composer tool.

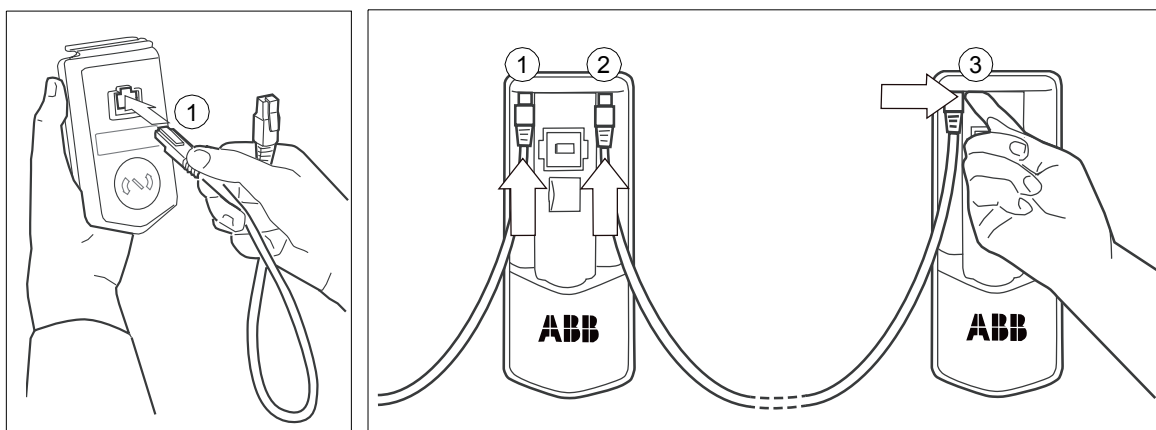

Installing option modules

■ Mechanical installation of I/O extension, fieldbus adapter and pulse encoder interface modules

See page 42 for the available slots for each module. Install the option modules as follows:



WARNING! Obey the instructions in chapter [Safety instructions](#). If you ignore them, injury or death, or damage to the equipment can occur.

1. Stop the drive and do the steps in section [Precautions before electrical work](#) on page 19 before you start the work.
2. Open the door of the auxiliary control cubicle (ACU).
3. Remove the shrouding at the top of the cubicle.
4. Locate the inverter control unit (A41).
5. Insert the module carefully into its position on the control unit.
6. Fasten the mounting screw. **Note:** The screw tightens the connections and grounds the module. It is essential for fulfilling the EMC requirements and for proper operation of the module.



■ Mechanical installation of an FSO-xx safety functions module

This procedure describes the mechanical installation of an FSO-xx safety functions module onto the inverter control unit. (The FSO-xx can alternatively be installed beside the control unit, which is the standard with factory-installed FSO-xx modules. For instructions, see the FSO-xx manual.)

1. Fasten the module onto slot 3 of the inverter control unit (A41) with four screws.

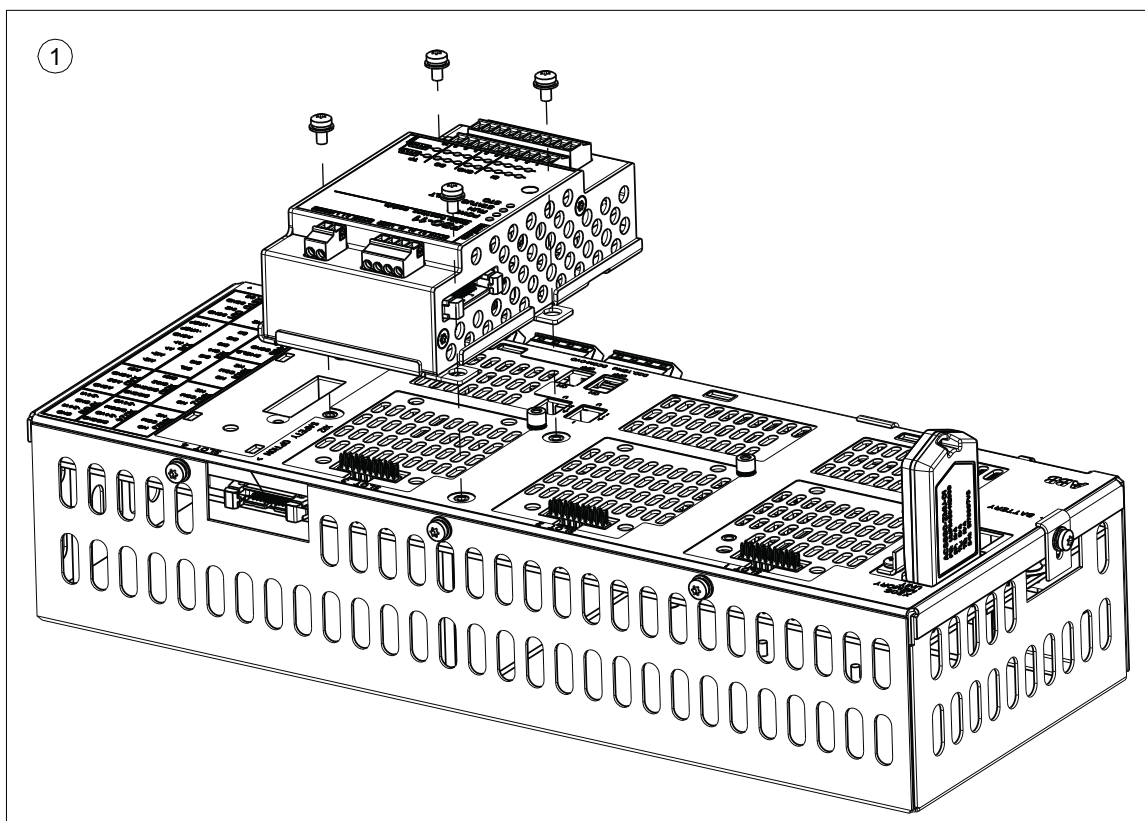

2. Tighten the FSO-xx electronics grounding screw.
3. Connect the FSO-xx data cable between FSO-xx connector X110 and to BCU-x2 connector X12.

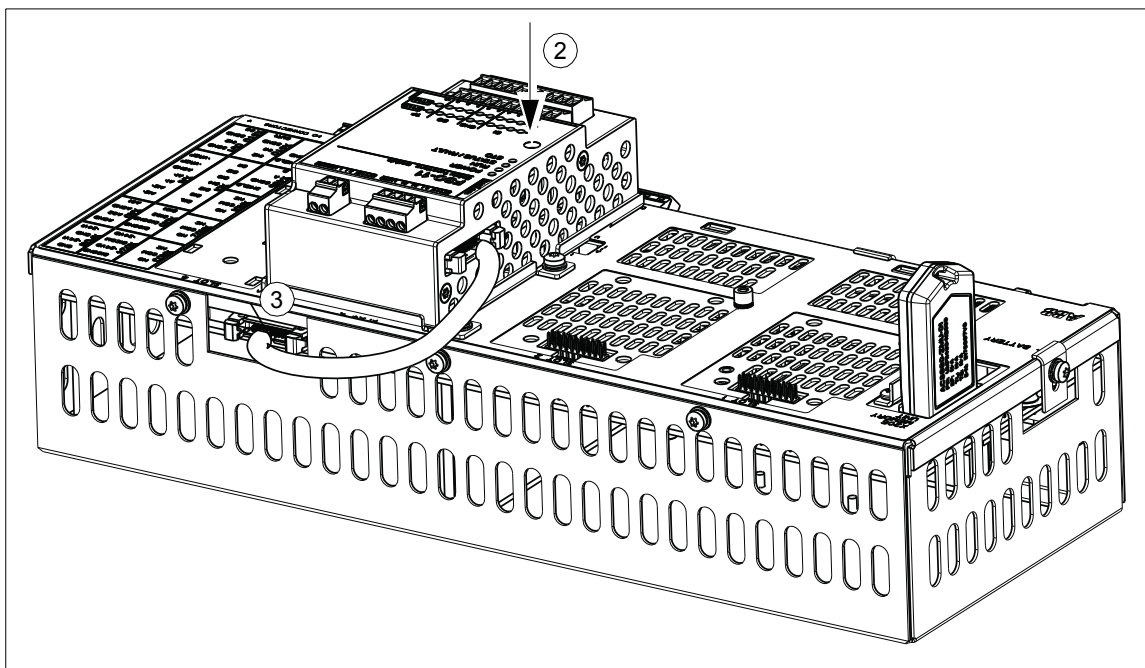

■ Wiring of optional modules

See the appropriate optional module manual for specific installation and wiring instructions.





Control units of the drive

What this chapter contains

This chapter

- describes the connections of the control units used in the drive,
- contains the specifications of the inputs and outputs of the control units.

General

The ACS880 drive utilizes BCU-x2 control units. The BCU-x2 consists of a BCON-12 control board (and a BIOC-01 I/O connector board and power supply board) built in a metal housing.

The supply and inverter units of the ACS880-07 are each controlled by a dedicated BCU-x2 control unit. The designation of the supply control unit is A51; the inverter control unit is A41. Both are located in the ACU cubicle (see the layout drawings in chapter [Operation principle and hardware description](#)), and connect to the power modules (ie. supply and inverter modules respectively) by fiber optic cables.

In this manual, the name “BCU-x2” represents the control unit types BCU-02 and BCU-12. These have a different number of power module connections (2 and 7 respectively) but are otherwise similar.

Control unit layout and connections

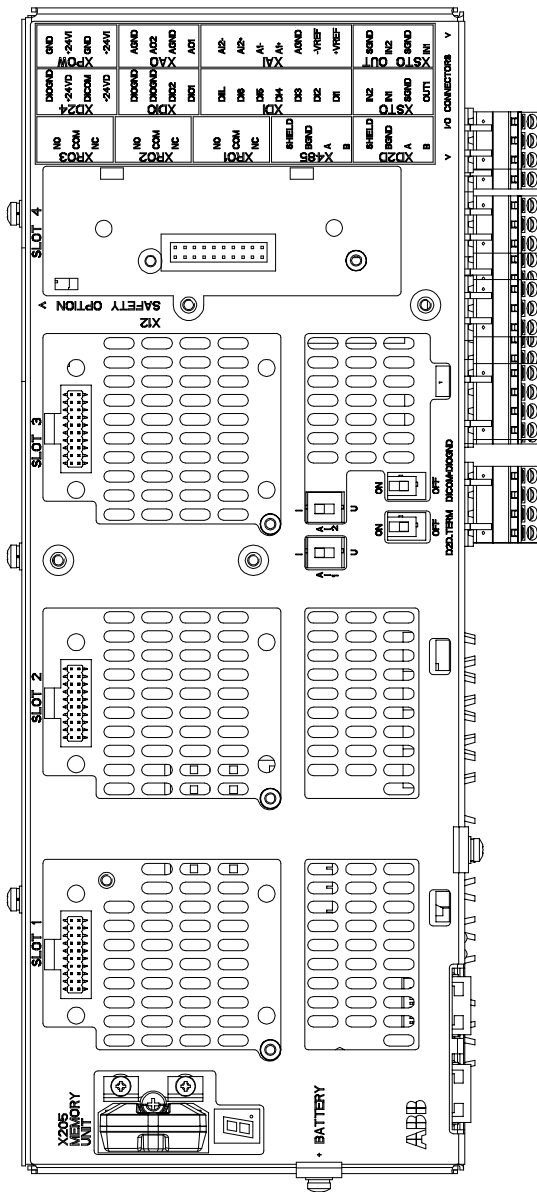

	Description
I/O	I/O terminals (see following diagram)
SLOT 1	I/O extension, encoder interface or fieldbus adapter module connection. (This is the sole location for an FDPI-02 diagnostics and panel interface.)
SLOT 2	I/O extension, encoder interface or fieldbus adapter module connection
SLOT 3	I/O extension, encoder interface, fieldbus adapter or FSO-xx safety functions module connection
SLOT 4	RDCO-0x DDCS communication option module connection
X205	Memory unit connection
BATTERY	Holder for real-time clock battery (CR 2032)
AI1	Mode selector for analog input AI1 (I = current, U = voltage)
AI2	Mode selector for analog input AI2 (I = current, U = voltage)
D2D TERM	Termination switch for drive-to-drive link (D2D)
DICOM= DIOGND	Ground selection. Determines whether DICOM is separated from DIOGND (ie. the common reference for the digital inputs floats). See the Ground isolation diagram (page 137).
7-segment display Multicharacter indications are displayed as repeated sequences of characters	
	("U" is indicated briefly before "o".) Control program startup in progress
	(Flashing) Firmware cannot be started. Memory unit missing or corrupted
	Firmware download from PC to control unit in progress
	At power-up, the display may show short indications of eg. "1", "2", "b" or "U". These are normal indications immediately after power-up. If the display ends up showing any other value than those described, it indicates a hardware failure.

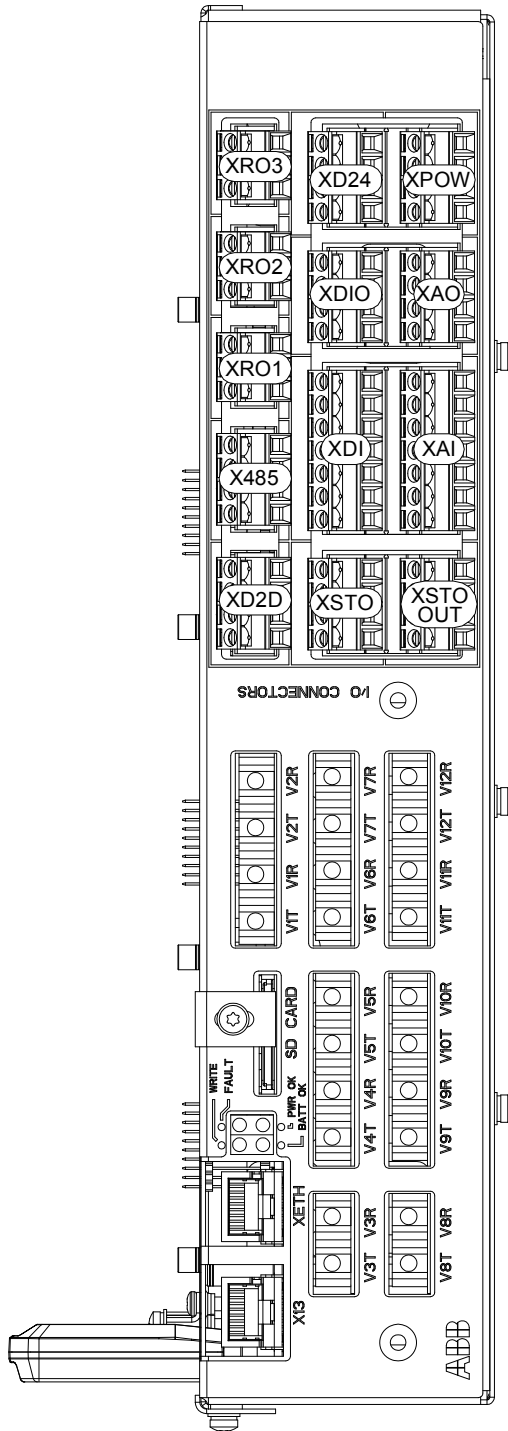

	Description
XAI	Analog inputs
XAO	Analog outputs
XDI	Digital inputs, Digital input interlock (DIIL)
XDIO	Digital input/outputs
XD2D	Drive-to-drive link
XD24	+24 V output (for digital inputs)
XETH	Ethernet port (eg. for PC communication)
XPOW	External power input
XRO1	Relay output RO1
XRO2	Relay output RO2
XRO3	Relay output RO3
XSTO	Safe torque off connection (input signals)
XSTO OUT	Safe torque off connection (to inverter modules)
X13	Control panel / PC connection
X485	Not in use













V1T/V1R, V2T/V2R	Fiber optic connection to inverter modules 1 and 2 (VxT = transmitter, VxR = receiver)
V3T/V3R ... V7T/V7R	Fiber optic connection to inverter modules 3...7 (BCU-12/22 only) (VxT = transmitter, VxR = receiver)
V8T/V8R ... V12T/V12R	Fiber optic connection to inverter modules 8...12 (BCU-22 only) (VxT = transmitter, VxR = receiver)

SD CARD	Data logger memory card for inverter module communication
---------	---

BATT OK	Real-time clock battery voltage is higher than 2.8 V. If the LED is off when the control unit is powered, replace the battery.
FAULT	The control program has generated a fault. See the firmware manual of the inverter unit.
PWR OK	Internal voltage supply is OK
WRITE	Writing to memory card in progress. Do not remove the memory card.

Default I/O diagram of the supply control unit (A51)

The diagram below shows the default I/O connections on the supply control unit (A51), and describes the use of the signals/connections in the supply unit. Under normal circumstances, the factory-made wiring should not be changed.

Relay outputs		XRO1...XRO3	
XRO1: Running (energized = running) 250 V AC / 30 V DC 2 A		NO	3
		COM	2
		NC	1
XRO2: Fault (-1) (energized = no fault) 250 V AC / 30 V DC 2 A		NO	3
		COM	2
		NC	1
XRO3: MCB ctrl (energized = main contactor/breaker closed) 250 V AC / 30 V DC 2 A		NO	3
		COM	2
		NC	1
Reference voltage and analog inputs		XAI	
10 V DC, R_L 1...10 kohm		+VREF	1
-10 V DC, R_L 1...10 kohm		-VREF	2
Ground		AGND	3
Not in use		AI1+	4
0(2)...10 V, $R_{in} > 200$ kohm		AI1-	5
Not in use		AI2+	6
0(4)...20 mA, $R_{in} = 100$ ohm		AI2-	7
Analog outputs		XAO	
Not in use		AO1	1
		AGND	2
Not in use		AO2	3
		AGND	4
Drive-to-drive link		XD2D	
Not in use		Shield	4
		BGND	3
		A	2
		B	1
Safe torque off		XSTO	
Safe torque off. Both circuits must be closed for the supply unit to start. (IN1 and IN2 must be connected to OUT.)		IN2	4
		IN1	3
		SGND	2
		OUT	1
Digital inputs		XDI	
Temperature fault (0 = overtemperature)		DI1	1
Run / enable (1 = run enable)		DI2	2
MCB feedback (1 = main contactor/breaker closed)		DI3	3
Circuit breaker fault (0 = auxiliary circuit breaker or switch open)		DI4	4
Ground (earth) fault (with optional ground fault monitoring)		DI5	5
Reset (0 → 1 = fault reset)		DI6	6
Emergency stop (0 = emergency stop activated) (units with em. stop option only)		DIIL	7
Digital input/outputs		XDIO	
Not in use		DIO1	1
Not in use		DIO2	2

■ Default I/O diagram of the inverter control unit (A41)

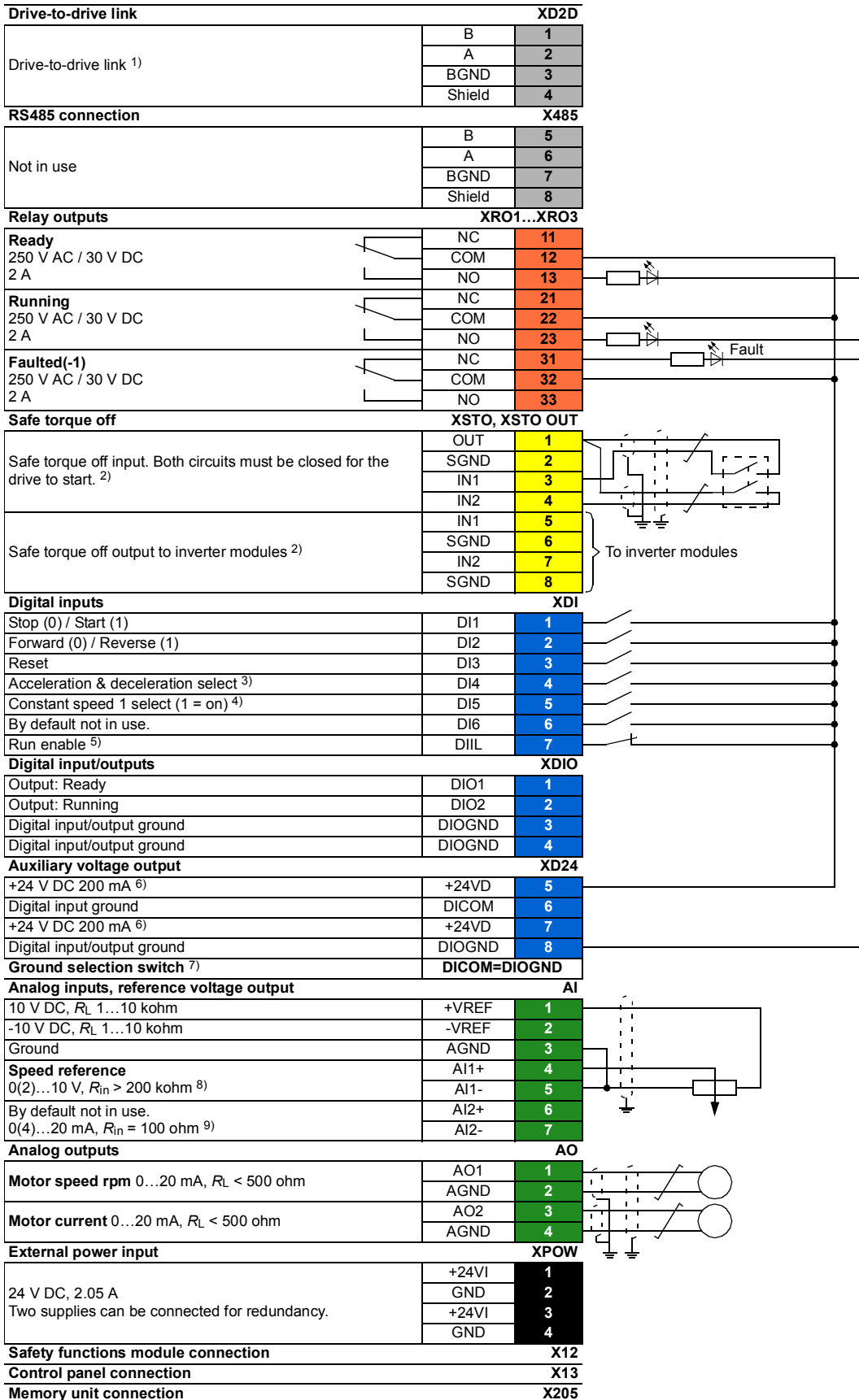

Notes:

The wire size accepted by all screw terminals (for both stranded and solid wire) is 0.5 ... 2.5 mm² (24...12 AWG). The torque is 0.5 N·m (5 lbf·in).

- 1) See section [Drive-to-drive link \(XD2D\)](#) (page 133).
- 2) See chapter [The Safe torque off function](#) (page 249).
- 3) 0 = Acceleration/deceleration ramps defined by parameters 23.12/23.13 in use.
1 = Acceleration/deceleration ramps defined by parameters 23.14/23.15 in use.
- 4) Constant speed 1 is defined by parameter 22.26.
- 5) See section [DIIL input](#) (page 133).
- 6) Total load capacity of these outputs is 4.8 W (200 mA at 24 V) minus the power taken by DIO1 and DIO2.
- 7) Determines whether DICOM is separated from DIOGND (ie. common reference for digital inputs floats; in practice, selects whether the digital inputs are used in current sinking or sourcing mode). See also [Ground isolation diagram](#) on page 137.
DICOM=DIOGND ON: DICOM connected to DIOGND. **OFF:** DICOM and DIOGND separate.
- 8) Current [0(4)...20 mA, $R_{in} = 100 \text{ ohm}$] or voltage [0(2)...10 V, $R_{in} > 200 \text{ kohm}$] input selected by switch **AI1**. Change of setting requires reboot of control unit.
- 9) Current [0(4)...20 mA, $R_{in} = 100 \text{ ohm}$] or voltage [0(2)...10 V, $R_{in} > 200 \text{ kohm}$] input selected by switch **AI2**. Change of setting requires reboot of control unit.

External power supply for the control unit (XPOW)

The BCU-x2 is powered from a 24 V DC, 2 A supply through terminal block XPOW. A second supply can be connected to the same terminal block for redundancy.

DI6 as a PTC sensor input

A PTC sensor can be connected to this input for motor temperature measurement as follows. The sensor can alternatively be connected to FEN-xx encoder interface module. Do not connect both ends of the cable shield directly to ground. If a capacitor cannot be used at one end, leave that end of the shield unconnected. See the firmware manual for parameter settings.

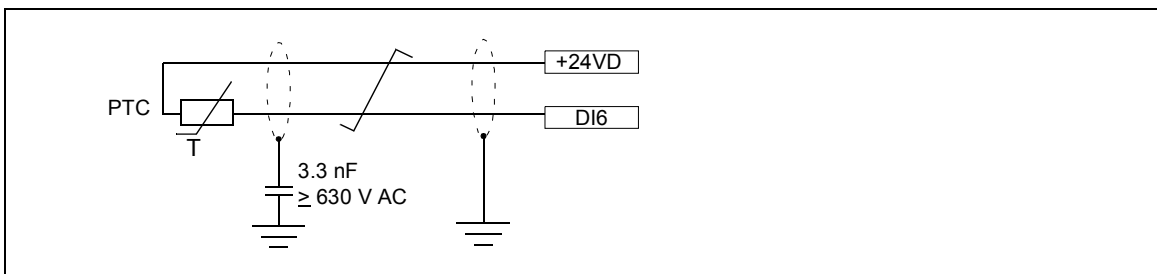



WARNING! As the inputs pictured above are not insulated according to IEC 60664, the connection of the motor temperature sensor requires double or reinforced insulation between motor live parts and the sensor. If the assembly does not fulfill the requirement, the I/O board terminals must be protected against contact and must not be connected to other equipment or the temperature sensor must be isolated from the I/O terminals.

■ AI1 or AI2 as a Pt100, Pt1000 or KTY84 sensor input

Three Pt100/Pt1000 sensors or one KTY84 sensor for motor temperature measurement can be connected between an analog input and output as shown below. (Alternatively, you can connect the KTY to an FIO-11 or FAIO-01 analog I/O extension module or FEN-xx encoder interface module.) Do not connect both ends of the cable shields directly to ground. If a capacitor cannot be used at one end, leave that end of the shield unconnected.

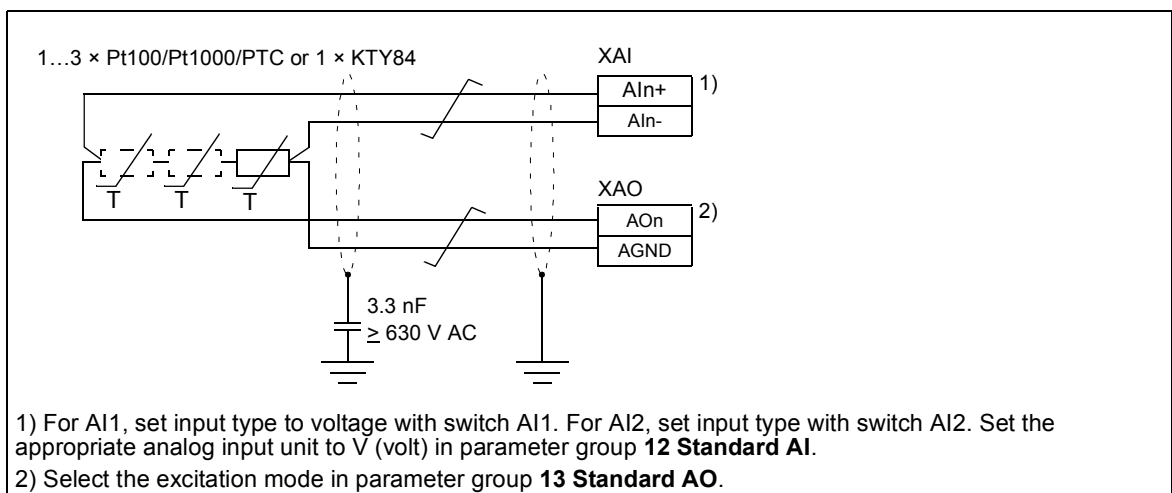

WARNING! As the inputs pictured above are not insulated according to IEC 60664, the connection of the motor temperature sensor requires double or reinforced insulation between motor live parts and the sensor. If the assembly does not fulfill the requirement, the I/O board terminals must be protected against contact and must not be connected to other equipment or the temperature sensor must be isolated from the I/O terminals.

■ DIIL input

On both the supply and inverter units, the DIIL input is used for the connection of safety circuits. The input is parametrized to stop the unit when the input signal is lost.

■ Drive-to-drive link (XD2D)

The drive-to-drive link is a daisy-chained RS-485 transmission line that allows basic master/follower communication with one master drive and multiple followers.

Enable bus termination on the inverters at the ends of the drive-to-drive link by setting switch D2D TERM on the control unit to ON. On intermediate inverters, disable bus termination.

Use shielded twisted-pair cable (~100 ohm, for example, PROFIBUS-compatible cable) for the wiring. For best immunity, high quality cable is recommended. Keep the cable as short

as possible; the maximum length of the link is 50 meters (164 ft). Avoid unnecessary loops and running the cable near power cables (such as motor cables). Ground the cable shields as described in section [Connecting the control cables](#) on page 97.

The following diagram shows the wiring of the drive-to-drive link.

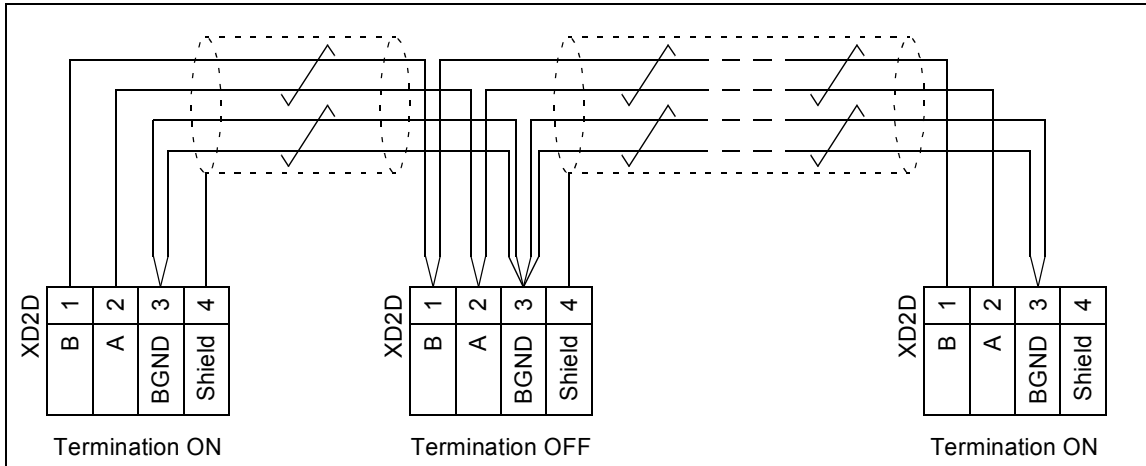

■ Safe torque off (XSTO, XSTO OUT)

On the inverter control unit (A41), the XSTO input can be used to implement a safe torque off (STO) function. For the drive to start, both connections (OUT1 to IN1 and IN2) must be closed. By default, the terminal block has jumpers to close the circuit. Remove the jumpers before connecting an external Safe torque off circuit to the drive. For information on the implementation of a Safe torque off function, see chapter [The Safe torque off function](#) (page 249).

Note: The XSTO input only acts as a true Safe torque off input on the inverter control unit [A41]. De-energizing the IN1 and/or IN2 terminals on the supply control unit [A51] will stop the supply unit but not constitute a true safety function.

The XSTO OUT connector is wired to the STO IN connector of one inverter module. In case the inverter unit consists of multiple modules, the STO OUT connector of one module is wired to the STO IN connector of the next module etc. so that all modules are part of the chain.

■ FSO-xx safety functions module connection (X12)

See section [Implementing the functions provided by the FSO-xx safety functions module \(option +Q972 or +Q973\)](#) (page 89), and the user manual of the FSO-xx module.

■ SDHC memory card slot

The BCU-x2 has an on-board data logger that collects real-time data from the power modules to help fault tracing and analysis. The data is stored onto the SDHC memory card inserted into the SD CARD slot and can be analyzed by ABB service personnel.

Control unit connector data

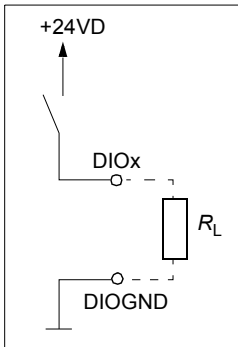
Power supply (XPOW)	<p>Connector pitch 5 mm, wire size 2.5 mm² 24 V ($\pm 10\%$) DC, 2 A External power input. Two supplies can be connected for redundancy.</p>
Relay outputs RO1...RO3 (XRO1...XRO3)	<p>Connector pitch 5 mm, wire size 2.5 mm² 250 V AC / 30 V DC, 2 A Protected by varistors</p>
+24 V output (XD24:2 and XD24:4)	<p>Connector pitch 5 mm, wire size 2.5 mm² Total load capacity of these outputs is 4.8 W (200 mA / 24 V) minus the power taken by DIO1 and DIO2.</p>
Digital inputs DI1...DI6 (XDI:1...XDI:6)	<p>Connector pitch 5 mm, wire size 2.5 mm² 24 V logic levels: "0" < 5 V, "1" > 15 V R_{in}: 2.0 kohm Input type: NPN/PNP (DI1...DI5), NPN (DI6) Hardware filtering: 0.04 ms, digital filtering up to 8 ms DI6 (XDI:6) can alternatively be used as an input for a PTC sensor. "0" > 4 kohm, "1" < 1.5 kohm I_{max}: 15 mA (DI1...DI5), 5 mA (DI6)</p>
Start interlock input DIIL (XDI:7)	<p>Connector pitch 5 mm, wire size 2.5 mm² 24 V logic levels: "0" < 5 V, "1" > 15 V R_{in}: 2.0 kohm Input type: NPN/PNP Hardware filtering: 0.04 ms, digital filtering up to 8 ms</p>
Digital inputs/outputs DIO1 and DIO2 (XDIO:1 and XDIO:2)	<p>Connector pitch 5 mm, wire size 2.5 mm² As inputs: 24 V logic levels: "0" < 5 V, "1" > 15 V R_{in}: 2.0 kohm Filtering: 1 ms As outputs: Total output current from +24VD is limited to 200 mA</p>
<p>Input/output mode selection by parameters. DIO1 can be configured as a frequency input (0...16 kHz with hardware filtering of 4 microseconds) for 24 V level square wave signal (sinusoidal or other wave form cannot be used). DIO2 can be configured as a 24 V level square wave frequency output. See the firmware manual, parameter group 11.</p>	
Reference voltage for analog inputs +VREF and -VREF (XAI:1 and XAI:2)	<p>Connector pitch 5 mm, wire size 2.5 mm² 10 V $\pm 1\%$ and -10 V $\pm 1\%$, R_{load} 1...10 kohm Maximum output current: 10 mA</p>
Analog inputs AI1 and AI2 (XAI:4 ... XAI:7).	<p>Connector pitch 5 mm, wire size 2.5 mm² Current input: -20...20 mA, R_{in} = 100 ohm Voltage input: -10...10 V, R_{in} > 200 kohm Differential inputs, common mode range ± 30 V Sampling interval per channel: 0.25 ms Hardware filtering: 0.25 ms, adjustable digital filtering up to 8 ms Resolution: 11 bit + sign bit Inaccuracy: 1% of full scale range</p>
<p>Current/voltage input mode selection by switches.</p>	

Analog outputs AO1 and AO2 (XAO)	Connector pitch 5 mm, wire size 2.5 mm ² 0...20 mA, $R_{load} < 500$ ohm Frequency range: 0...500 Hz Resolution: 11 bit + sign bit Inaccuracy: 2% of full scale range
Drive-to-drive link (XD2D)	Connector pitch 5 mm, wire size 2.5 mm ² Physical layer: RS-485 Termination by jumper
RS-485 connection (X485)	Connector pitch 5 mm, wire size 2.5 mm ² Physical layer: RS-485
Safe torque off connection (XSTO)	Connector pitch 5 mm, wire size 2.5 mm ² Input voltage range: -3...30 V DC Logic levels: "0" < 5 V, "1" > 17 V For the unit to start, both connections must be "1" Current consumption: 66 mA (continuous) per STO channel per R8i inverter module EMC (immunity) according to IEC 61326-3-1
Safe torque off output (XSTO OUT)	Connector pitch 5 mm, wire size 2.5 mm ² To STO connector of inverter module. See chapter The Safe torque off function (page 249).
Control panel connection (X13)	Connector: RJ-45 Cable length < 3 m
Ethernet connection (XETH)	Connector: RJ-45
SDHC memory card slot (SD CARD)	Memory card type: SDHC Maximum memory size: 4 GB

The terminals of the control unit fulfill the Protective Extra Low Voltage (PELV) requirements. The PELV requirements of a relay output are not fulfilled if a voltage higher than 48 V is connected to the relay output.

Ground isolation diagram

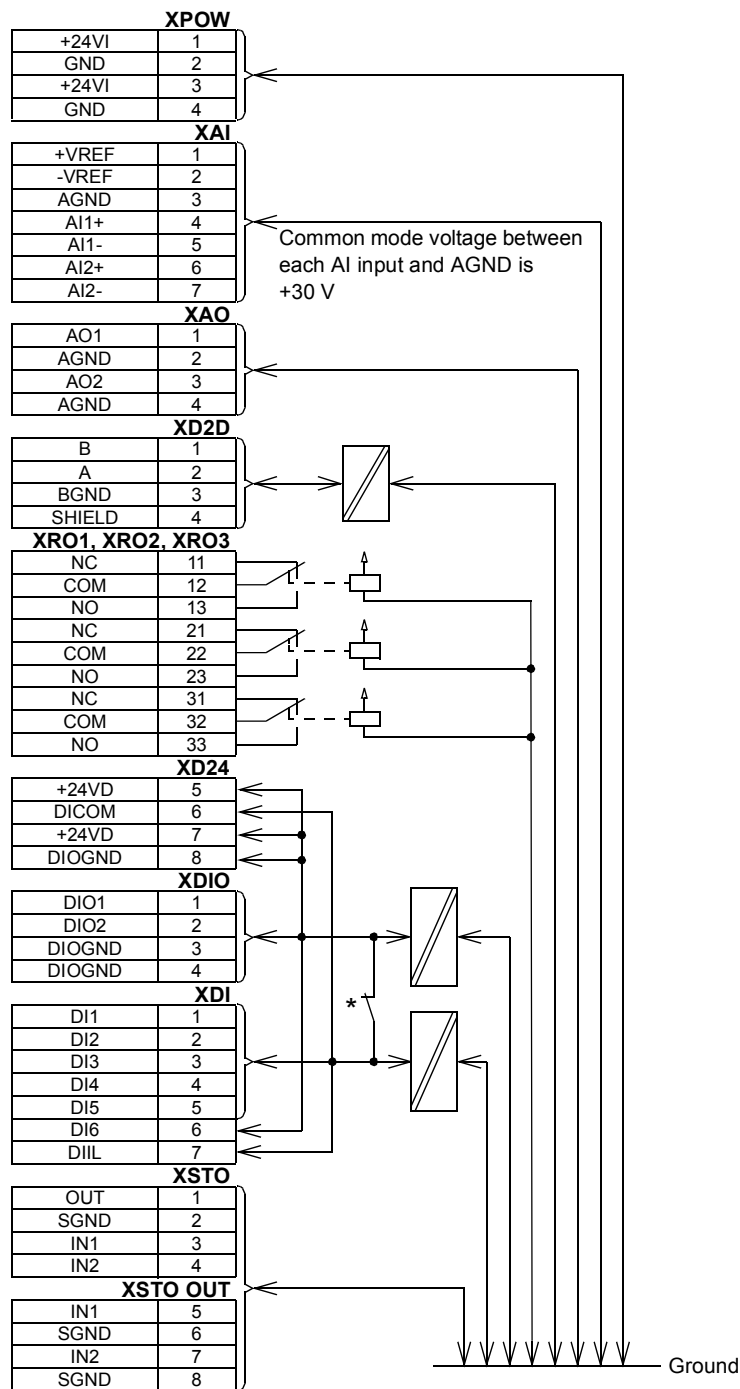

***Ground selector (DICOM=DIOGND) settings**

DICOM=DIOGND: ON

All digital inputs share a common ground (DICOM connected to DIOGND). This is the default setting.

DICOM=DIOGND: OFF

Ground of digital inputs DI1...DI5 and DIIL (DICOM) is isolated from DIO signal ground (DIOGND). Isolation voltage 50 V.

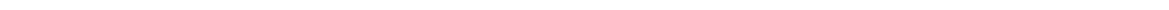

8

Installation checklist

Contents of this chapter

This chapter contains an installation checklist which you must complete before you start up the drive.

Warnings



WARNING! Obey the instructions in chapter [Safety instructions](#). If you ignore them, injury or death, or damage to the equipment can occur.

Checklist

Do the steps in section [Precautions before electrical work](#) on page 19 before you start the work. Go through the checklist together with another person..

Check that ...	<input checked="" type="checkbox"/>
The ambient operating conditions meet the specifications given in chapter Technical data .	<input type="checkbox"/>
The drive cabinet has been fixed to floor, and if necessary due to vibration etc, also from top to the wall or roof.	<input type="checkbox"/>
The cooling air will flow freely in and out of the drive cabinet,	<input type="checkbox"/>
<u>If the drive will be connected to an IT (ungrounded) or a corner grounded TN network:</u> The optional EMC filter (+E200, +E202) of the drive (if any) has been disconnected. See page 94.	<input type="checkbox"/>
<u>If the drive has been stored over one year:</u> The electrolytic DC capacitors in the DC link of the drive have been reformed. See Converter module capacitor reforming instructions (3BFE64059629 [English]).	<input type="checkbox"/>

Check that ...	<input checked="" type="checkbox"/>
There is an adequately sized protective earth (ground) conductor between the drive and the switchboard, and the conductor has been connected to appropriate terminal. Proper grounding has also been measured according to the regulations.	<input type="checkbox"/>
There is an adequately sized protective earth (ground) conductor between the motor and the drive, and the conductor has been connected to appropriate terminal. Proper grounding has also been measured according to the regulations.	<input type="checkbox"/>
<u>Only for drives with option +D150:</u> There is an adequately sized protective earth (ground) conductor between the user-installed brake resistor and the drive, and the conductor has been connected to appropriate terminal. Proper grounding has also been measured according to the regulations.	<input type="checkbox"/>
The supply voltage matches the nominal input voltage of the drive. Check the type designation label.	<input type="checkbox"/>
The voltage setting of the auxiliary voltage transformers T21 (standard), T101 (option-specific) and T111 (option-specific) is correct. See page 94.	<input type="checkbox"/>
The input power cable has been connected to the appropriate terminals, the phase order is right, and the terminals have been tightened. (Pull the conductors to check.)	<input type="checkbox"/>
The motor cable has been connected to the appropriate terminals, the phase order is right, and the terminals have been tightened. (Pull the conductors to check.)	<input type="checkbox"/>
The motor cable (and brake resistor cable, if present) has been routed away from other cables.	<input type="checkbox"/>
No power factor compensation capacitors have been connected to the motor cable.	<input type="checkbox"/>
<u>If a drive bypass connection will be used:</u> The direct-on-line contactor of the motor and the drive output contactor are either mechanically or electrically interlocked, ie, cannot be closed simultaneously.	<input type="checkbox"/>
The external brake resistor (if present) has been connected to the appropriate terminals, and the terminals have been tightened. (Pull the conductors to check.)	<input type="checkbox"/>
The brake resistor cable has been routed away from other cables.	<input type="checkbox"/>
The control cables have been connected to the appropriate terminals, and the terminals have been tightened. (Pull the conductors to check.)	<input type="checkbox"/>
There are no tools, foreign objects or dust from drilling inside the drive.	<input type="checkbox"/>
All shrouds and cover of the motor connection box are in place. Cabinet doors have been closed.	<input type="checkbox"/>
The motor and the driven equipment are ready for start.	<input type="checkbox"/>

9

Start-up

Contents of this chapter

This chapter contains the start-up procedure of the drive.

Start-up procedure

The tasks which are needed in certain cases only are marked with underlining, and option codes are given in brackets. Default device designations (if any) are given in brackets after the name, for example “main switch-disconnector [Q1]”. The same device designations are also used in the circuit diagrams, typically.

These instructions cannot and do not cover all possible start-up tasks of a customized drive. Always refer to the delivery-specific circuit diagrams when proceeding with the start-up.



WARNING! Only qualified electricians are allowed to do the work described in this chapter.

Note: For certain functional safety options (such as +Q952, +Q953, +Q957, +Q963 and +Q964), the start-up instructions are given in their separate manuals rather than in this chapter. See the listing of manuals inside the front cover.



Action	<input checked="" type="checkbox"/>
Safety	
 WARNING! Obey the safety instructions during the start-up procedure. See chapter Safety instructions on page 15.	<input type="checkbox"/>
Checks/Settings with no voltage connected	
Ensure that the disconnecter of the supply transformer is locked to the off (0) position, ie. no voltage is, and cannot be connected to the drive inadvertently.	<input type="checkbox"/>
Check that the main switch-disconnector (Q1.1) is switched off, or main breaker (Q1) racked out. Note: Some 12-pulse units are equipped with two switch-disconnectors or breakers – check that both are open before you proceed.	<input type="checkbox"/>
<u>Check that the grounding switch (Q9.1) (option +F259) is switched on. 12-pulse units have two switches, Q9.1 and Q9.2.</u>	<input type="checkbox"/>
Check the mechanical and electrical installation of the drive. See Installation checklist on page 139.	<input type="checkbox"/>
Check the settings of breakers/switches in the auxiliary circuits. See the circuit diagrams delivered with the drive.	<input type="checkbox"/>
Disconnect any unfinished or uninspected auxiliary voltage (115/230 V AC) cables that lead from the terminal blocks to the outside of the equipment.	<input type="checkbox"/>
Check that both channels of the Safe torque off circuit connected to the STO inputs of both the supply control unit [A51] and the inverter control unit [A41] are closed. Refer to the wiring diagrams delivered with the drive.	<input type="checkbox"/>
If the Safe torque off functionality is used, check that the STO OUT output on the inverter control unit (A41) is chained to the STO inputs of all inverter modules. If the Safe torque off functionality is not used, check that the STO input on all inverter modules is correctly wired to +24 V and ground.	<input type="checkbox"/>
<u>Drives with ground fault monitoring for IT (ungrounded) systems (option +Q954):</u> Adjust the settings of the ground fault monitor to suit the installation. See the circuit diagrams of the delivery and <i>IRDH275B Ground Fault Monitor Operating Manual</i> by Bender (code: TGH1386en).	<input type="checkbox"/>
<u>Drives with Pt100 relays (option +(n)L506):</u> <ul style="list-style-type: none"> • Check the connections against the circuit diagrams of the delivery. • Set the alarm and trip levels of the Pt100 relays. Set the alarm and trip levels of the Pt100 relay as low as possible based on the operating temperature and test results of the machine. The trip level can be set, for example, 10 °C higher than what the temperature of the machine is at maximal load in the maximum environmental temperature. We recommend to set the operating temperatures of the relay, typically for example, as follows: <ul style="list-style-type: none"> • 120...140 °C when only tripping is in use • alarm 120...140 °C and trip 130...150 °C when both alarm and tripping are used. 	<input type="checkbox"/>
Powering up the auxiliary circuit of the drive	
Make sure that it is safe to connect voltage. Ensure that <ul style="list-style-type: none"> • nobody is working on the drive or circuits that have been wired from outside into the drive cabinet • the cover of the motor terminal box is in place. 	<input type="checkbox"/>
<u>Drives with a voltmeter (option +G334):</u> Make sure that the circuit breaker of the measuring circuit (F5.1) is closed.	<input type="checkbox"/>
Close the circuit breakers supplying the auxiliary circuits.	<input type="checkbox"/>
Close the cabinet doors.	<input type="checkbox"/>
Close the main breaker of the supply transformer.	<input type="checkbox"/>



Action	<input checked="" type="checkbox"/>
Switch on the auxiliary voltage (Q21).	<input type="checkbox"/>
Setting up the supply unit parameters	
Check the voltage range setting in parameter <i>195.01 Supply voltage</i> . For more information on setting up the supply control program, see the <i>ACS880 diode supply control program firmware manual</i> (3AUA0000103295 [English]).	<input type="checkbox"/>
Setting up the drive parameters, and performing the first start	
Set up the inverter control program. See the appropriate start-up guide and/or firmware manual. There is a separate start-up guide only for some control programs. If you need more information on the use of the control panel, see <i>ACS-AP-X Assistant control panels user's manual</i> (3AUA0000085685 [English]).	<input type="checkbox"/>
Check that parameter <i>95.09 Fuse switch control</i> is disabled.	<input type="checkbox"/>
<u>Drives with a brake chopper (option +D150):</u> Refer also to chapter <i>Resistor braking</i> , section <i>Start-up</i> (page 268).	<input type="checkbox"/>
<u>Drives with a sine output filter (option +E206):</u> Check that bit 1 of parameter <i>95.15 Special HW settings</i> is activated.	<input type="checkbox"/>
<u>Drives with an fieldbus adapter module (optional):</u> Set the fieldbus parameters. Activate the appropriate assistant in the control program, or see the user's manual of the fieldbus adapter module, and the drive firmware manual. Not all control programs include assistants. Check that the communication works between the drive and the PLC.	<input type="checkbox"/>
<u>Drives with an encoder interface module (optional):</u> Set the encoder parameters. Activate the appropriate assistant in the control program, or see the user's manual of the encoder interface module, and the drive firmware manual. Not all control programs include assistants.	<input type="checkbox"/>
Powering up the main circuit of the drive	
<u>Switch the grounding switch (Q9.1) (option +F259) off. 12-pulse units have two grounding switches, Q9.1 and Q9.2.</u>	<input type="checkbox"/>
Close the main switch-disconnector (Q1.1) or main breaker (Q1). Note: Do not use excessive force. The main switch-disconnector (or main breaker) can only be closed when <ul style="list-style-type: none"> • the main input terminals (L1, L2, L3) are powered, and • auxiliary voltage is switched on (Q21), and • <u>grounding switch is off (Q9.1, Q9.2) (option +F259).</u> 	<input type="checkbox"/>
Turn the operating switch (S21) to the ON (1) position to activate the run enable signal. Depending on control source settings, this may also close the main contactor (if present). If a main contactor is present and does not close, refer to the circuit diagrams delivered by the drive as well as the appropriate firmware manuals.	<input type="checkbox"/>
On-load checks	
Start the motor to perform the ID run.	<input type="checkbox"/>
Check that the cooling fans rotate freely in the right direction, and the air flows upwards. A paper sheet set on the intake (door) gratings stays. The fans run noiselessly.	<input type="checkbox"/>
Check that the motor starts, stops and follows the speed reference in the correct direction when controlled with the control panel.	<input type="checkbox"/>
Check that the motor starts, stops and follows the speed reference in the correct direction when controlled through the customer-specific I/O or fieldbus.	<input type="checkbox"/>



Action	<input checked="" type="checkbox"/>
<u>Drives in which the Safe torque off control circuit is connected in use:</u> Test and validate the operation of the Safe torque off function. See Start-up including acceptance test (page 255).	<input type="checkbox"/>
<u>Drives with an emergency stop circuit (options +Q951, +Q952, +Q963, +Q964, +Q978, +Q979):</u> Test and validate the operation of the emergency-stop circuit. See the delivery specific circuit diagrams and wiring, start-up and operating instructions of the option (see page 88).	<input type="checkbox"/>
<u>Drives with the Prevention of unexpected start-up with safety relay (option +Q957):</u> Test and validate the operation of the Prevention of unexpected start-up circuit. See the delivery specific circuit diagrams and wiring, start-up and operating instructions of the option (see page 88).	<input type="checkbox"/>
<u>Test and validate the operation of Prevention of unexpected start with FSO-xx (option +Q950)</u>	<input type="checkbox"/>





Fault tracing

Contents of this chapter

This chapter describes the fault tracing possibilities of the drive.

LEDs

Where	LED	Color	Indication
Control panel mounting platform	POWER	Green	Control unit is powered and +15 V is supplied to the control panel.
	FAULT	Red	Drive in fault state.
Supply or inverter control unit (A51 or A41)	BATT OK	Green	Battery voltage of the real-time clock is OK (higher than 2.8 V). When the LED is not lit, <ul style="list-style-type: none"> • battery voltage is below 2.8 V, • the battery is missing, or • the control unit is not powered.
	PWR OK	Green	Internal voltage OK
	FAULT	Red	The control program indicates that the equipment is faulty. See the appropriate firmware manual.
	WRITE	Yellow	Writing to SD card in progress.

Warning and fault messages

See the firmware manual for the descriptions, causes and remedies of the drive control program warning and fault messages.



Component	Years from start-up																				
	1	2	3	4	5	6	7	8	9	10	11	12	13	14	15	16	17	18	19	20	21
Tightness of terminals	(I)	(I)	(I)	(I)	(I)	(I)	(I)	(I)	(I)	(I)	(I)	(I)	(I)	(I)	(I)	(I)	(I)	(I)	(I)	(I)	(I)
Dustiness, corrosion and temperature	(I)	(I)	(I)	(I)	(I)	(I)	(I)	(I)	(I)	(I)	(I)	(I)	(I)	(I)	(I)	(I)	(I)	(I)	(I)	(I)	(I)
Supply and inverter module heat sink cleaning	(I)	(I)	(I)	(I)	(I)	(I)	(I)	(I)	(I)	(I)	(I)	(I)	(I)	(I)	(I)	(I)	(I)	(I)	(I)	(I)	(I)
Spare parts																					
DC capacitor reforming	P	P	P	P	P	P	P	P	P	P	P	P	P	P	P	P	P	P	P	P	P

- I Visual inspection and maintenance action if needed
- (I) We recommend annual visual inspection and corrective actions if needed if the operating conditions are especially dusty or moist or ambient temperature is constantly high.
- P Non-site work
- R Replacement of component. Required conditions: ambient temperature is below 40 °C (104 °F) and there is no cyclic heavy load or continuous nominal load.
- (R) Replacement of component in demanding operation conditions:
- * (R) if ambient temperature is higher than 40 °C (104 °F) or operation is continuous or maintenance counter indicates replacement.
- 1) For replacement contact ABB.

Cabinet

■ Cleaning the interior of the cabinet



WARNING! Obey the instructions in chapter [Safety instructions](#). If you ignore them, injury or death, or damage to the equipment can occur.



WARNING! Use a vacuum cleaner with an antistatic hose and nozzle, and wear a grounding wristband. Otherwise an electrostatic charge might build up and damage the circuit boards.

1. Stop the drive and do the steps in section [Precautions before electrical work](#) on page [19](#) before you start the work.
2. Open the cabinet doors.
3. Clean the interior of the cabinet. Use a vacuum cleaner and a soft brush.
4. Clean the air inlets of the fans and air outlets of the modules (top).
5. Clean the air inlet gratings on the doors (see below).
6. Close the doors.

■ Cleaning the door air inlets (IP22 and IP42)

1. Remove the fasteners at the top of the grating.
2. Lift the grating and pull it away from the door.
3. Clean the stainless steel mesh and grating. If necessary, remove the mesh by turning the clips gently.
4. Install the mesh and grating in reverse order.

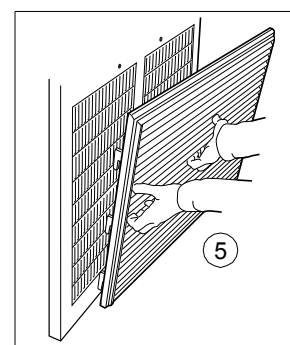
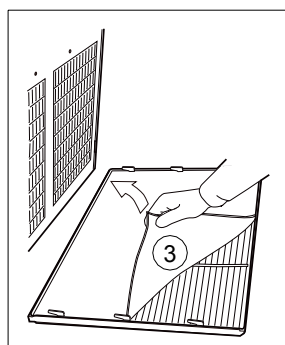
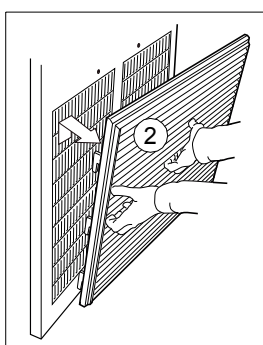
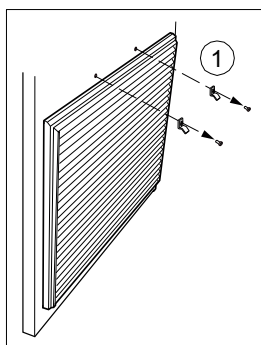

■ **Cleaning the door air inlets (IP54)**

1. Remove the fasteners at the top of the grating.
2. Lift the grating and pull it away from the door.
3. Remove the air filter mat.
4. Place the new filter mat in the grating the metal wire side facing the door.
5. Reinstall the grating in reverse order.

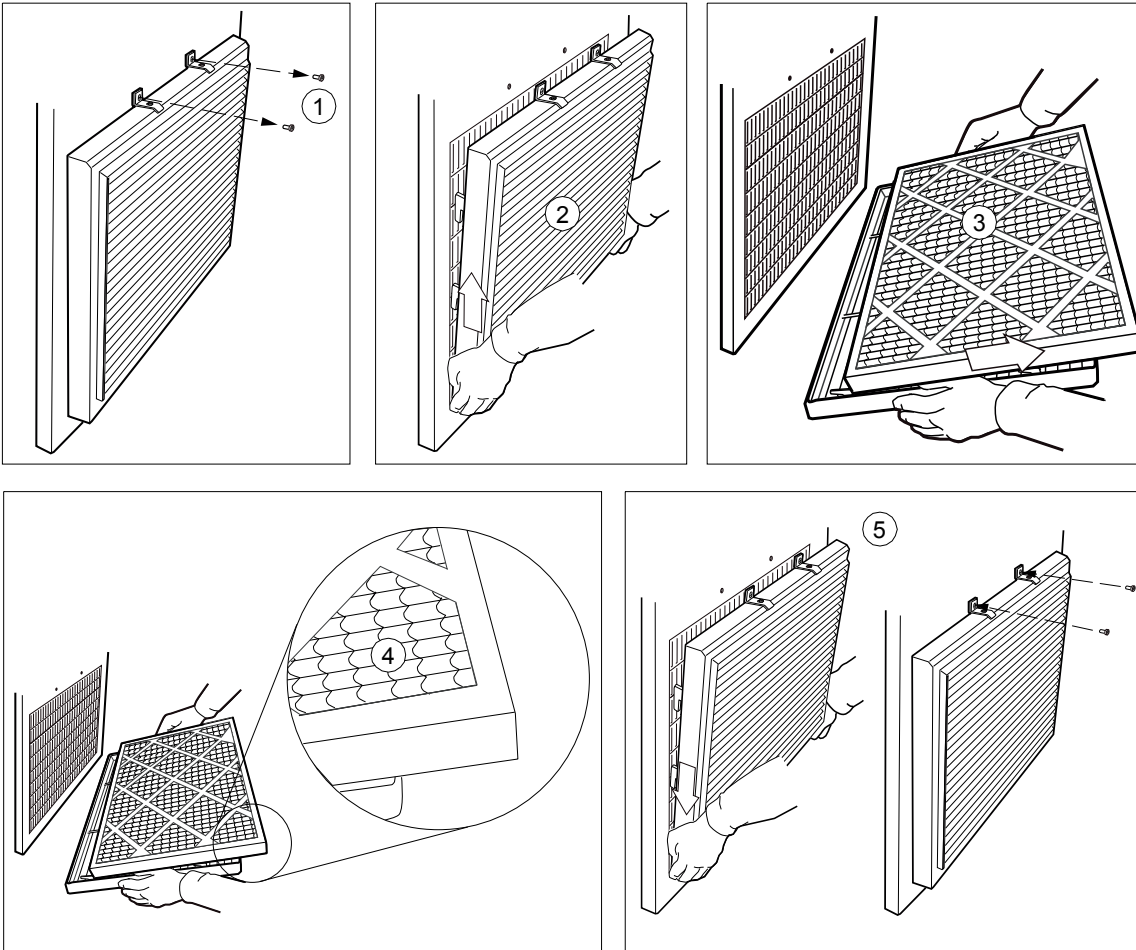

■ **Cleaning the outlet (roof) filters (IP54)**

The outlet (roof) filters in IP54 units can be accessed by pulling the gratings upwards.

■ **Replacing the outlet (roof) filters (IP54)**

1. Remove the front and back gratings of the fan cubicle by lifting them upwards
2. Remove the air filter mat.
3. Place the new filter mat in the grating.
4. Reinstall the grating in reverse order.

Heatsink

The drive module heatsink fins pick up dust from the cooling air. The drive runs into overtemperature warnings and faults if the heatsink is not clean. When necessary, clean the heatsink as follows.



WARNING! Obey the instructions in chapter [Safety instructions](#). If you ignore them, injury or death, or damage to the equipment can occur.



WARNING! Use a vacuum cleaner with antistatic hose and nozzle. Using a normal vacuum cleaner creates static discharges which can damage circuit boards.

1. Stop the drive and do the steps in section [Precautions before electrical work](#) (page 19) before you start the work.
2. Remove the drive module from the cabinet.
3. Remove the module cooling fan(s). See section [Fans](#) below.
4. Blow dry, clean compressed air from bottom to top and simultaneously use a vacuum cleaner at the air outlet to trap the dust. **Note:** If there is a risk of dust entering adjoining equipment, perform the cleaning in another room.
5. Reinstall the cooling fan.

Power connections and quick connectors

■ Retightening the power connections



WARNING! Obey the instructions in chapter [Safety instructions](#). If you ignore them, injury or death, or damage to the equipment can occur.

1. Stop the drive (if running) and do the steps in section [Precautions before electrical work](#) (page 19) before you start the work.
 2. Check the tightness of the cable connections. Use the tightening torques given in chapter [Technical data](#).
-

Fans

The lifespan of the cooling fans of the drive depends on the running time, ambient temperature and dust concentration. See the firmware manual for the actual signal which indicates the running time of the cooling fan. Reset the running time signal after fan replacement.

Replacement fans are available from ABB. Do not use other than ABB specified spare parts.

■ Replacing the cooling fan in the auxiliary control cubicle



WARNING! Obey the instructions in chapter [Safety instructions](#). If you ignore them, injury or death, or damage to the equipment can occur.

1. Stop the drive and do the steps in section [Precautions before electrical work](#) (page 19) before you start the work.
 2. Remove the shrouding from in front of the fan.
 3. Unplug the power supply cable of the fan.
 4. Remove the fastening screws of the fan.
 5. Install the new fan in reverse order.
-

■ Replacing the cooling fan(s) in the incoming cubicle

One or two cooling fans are installed in the incoming cubicle(s) (ICU).



WARNING! Obey the instructions in chapter [Safety instructions](#). If you ignore them, injury or death, or damage to the equipment can occur.

1. Stop the drive and do the steps in section [Precautions before electrical work](#) (page 19) before you start the work.
2. Remove the shrouding (if any) in front of the fan.
3. Disconnect the fan wiring (a).
4. Remove the fastening screws (a) and finger guard (b) of the fan.
5. Install the new fan in reverse order.

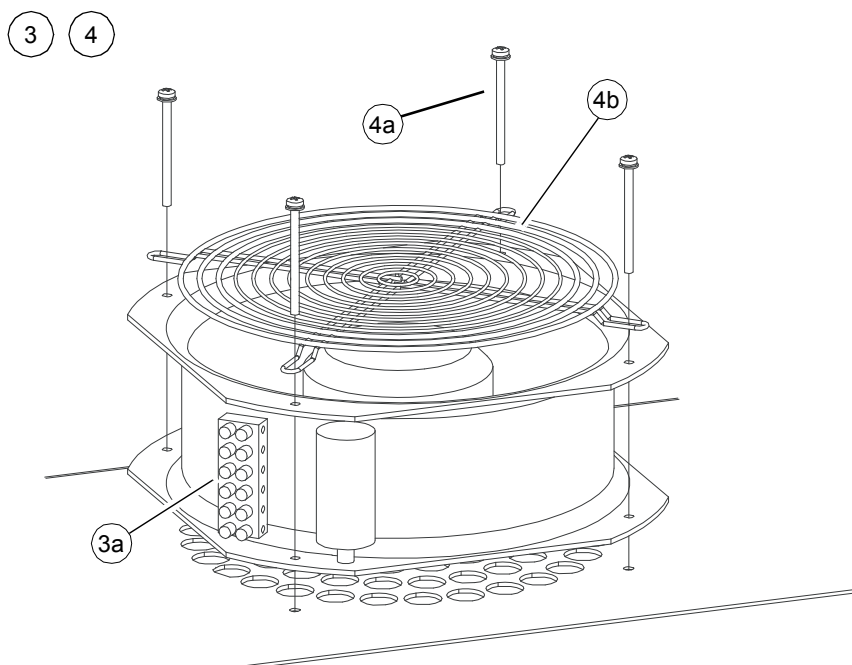

■ Replacing a roof fan (IP54/UL type 12)



WARNING! Obey the instructions in chapter [Safety instructions](#). If you ignore them, injury or death, or damage to the equipment can occur.

1. Stop the drive and do the steps in section [Precautions before electrical work](#) on page [19](#) before you start the work.
2. Lift the front and back gratings upwards and remove them.
3. Loosen the mounting screws of the fan cover.
4. Lift the cover off.
5. Disconnect the fan supply wires.
6. Loosen the mounting screws of the fan.
7. Lift the fan off.
8. Install the new fan in reverse order.

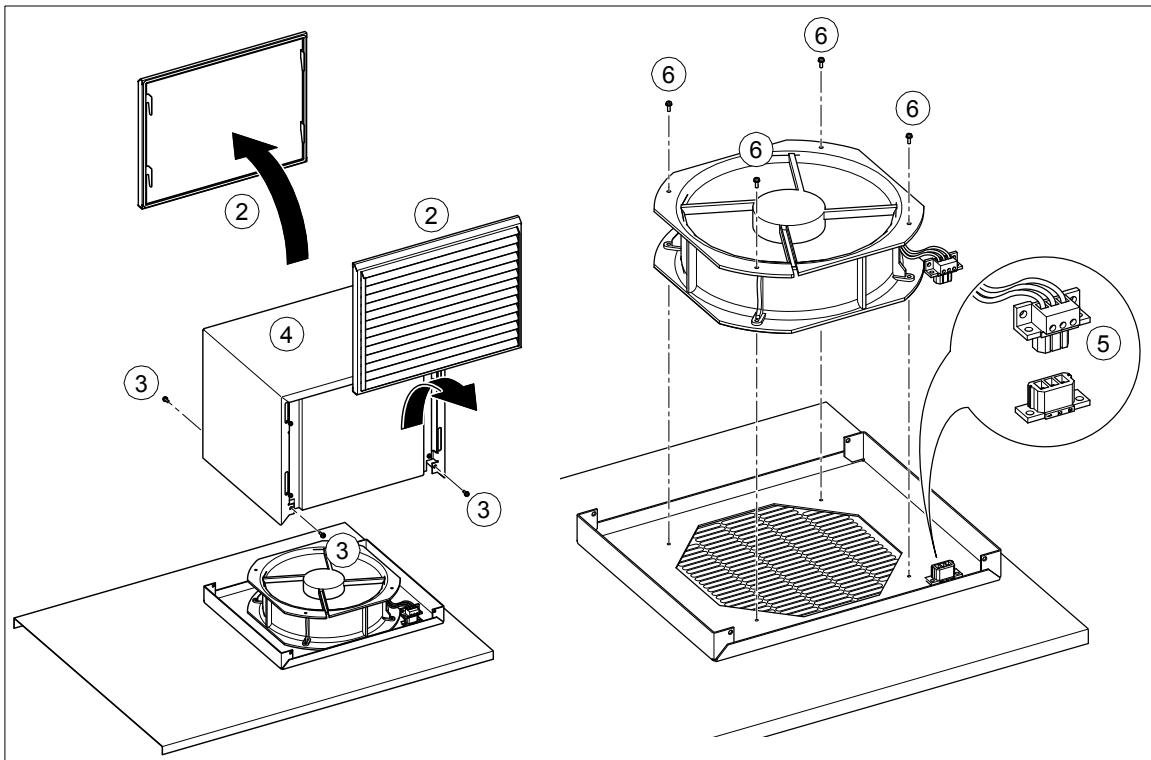

Replacing a supply module (D7T) cooling fan



WARNING! Only qualified electricians are allowed to do this work. Read the complete safety instructions of the drive. Ignoring the instructions can cause physical injury or death, or damage to the equipment.

1. Disconnect the drive from the AC power line and make sure it is safe to start the work. See section [Precautions before electrical work](#) (page 19).
2. Open the cubicle door.
3. Remove the lower support bracket (a) of the module.
4. Remove the front cover of the fan holder (b).
5. Disconnect the fan wiring from the module: power supply plug and fibre optic cables (c).
6. Support the fan holder (d) from below and pull it to release it from the module.
7. Pull out the fan holder.
8. Transfer the fan control box (e) from the old fan holder to the new fan holder.
9. Install the fan holder in reverse order to the above.

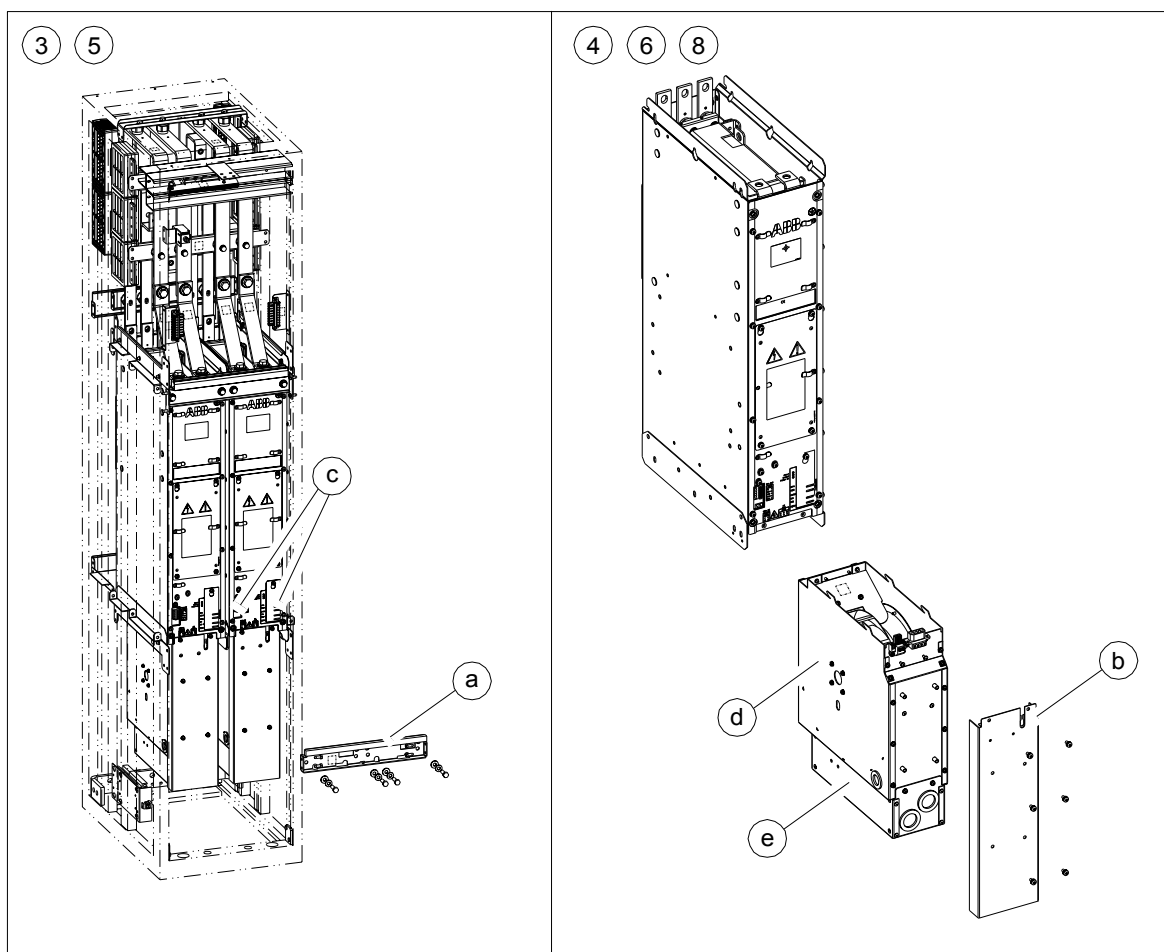

■ Replacing a supply (D8T) or inverter module cooling fan



WARNING! Obey the instructions in chapter [Safety instructions](#). If you ignore them, injury or death, or damage to the equipment can occur.

1. Stop the drive and do the steps in section [Precautions before electrical work](#) (page 19) before you start the work.
2. Open the cubicle door.
3. Remove the shroud in front of the fan.
4. Remove the cover panel in front of the fan.
5. Unplug the wiring of the fan.
6. Remove the fan control box.
7. Undo the screws of the fan unit.
8. Pull the fan unit out.
9. Install the new fan in reverse order.

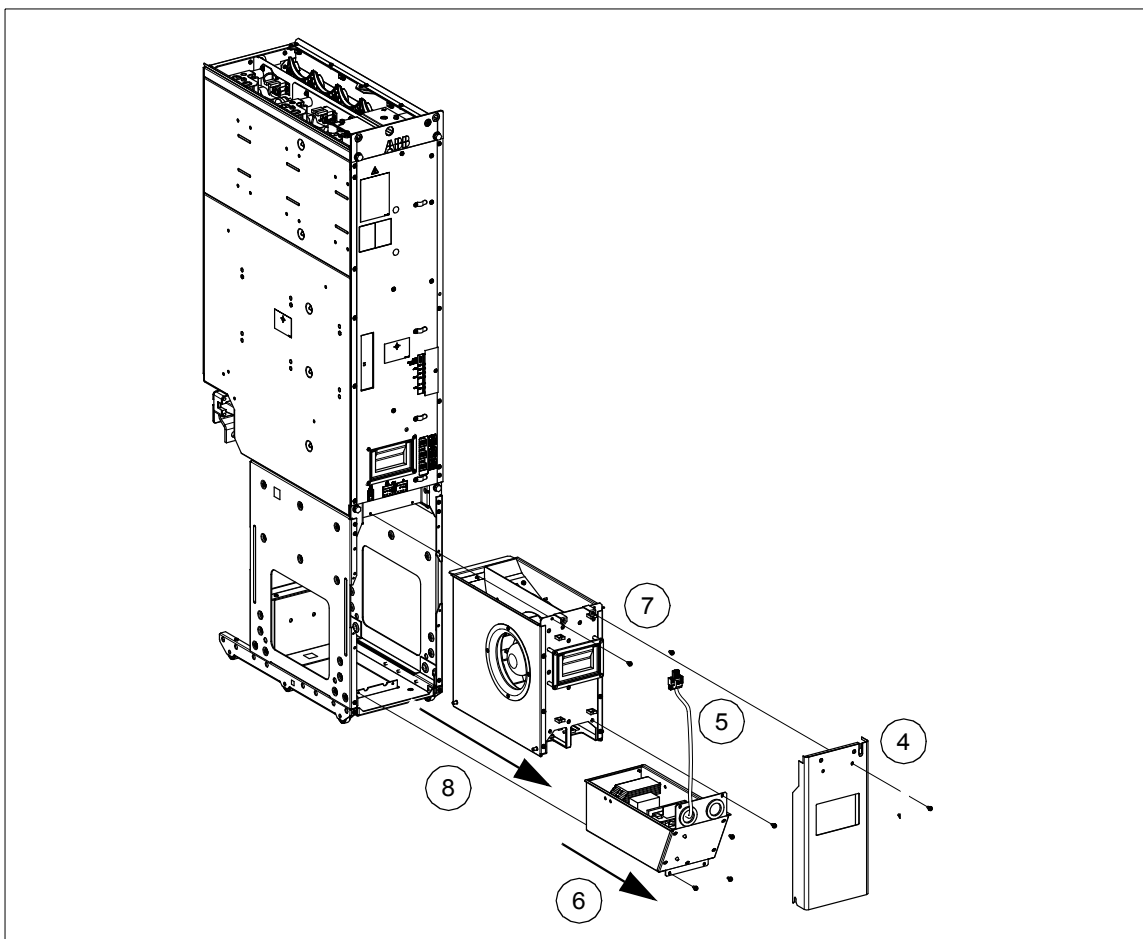

Replacing a frame D7T supply module



WARNING! Only qualified electricians are allowed to do this work. Read the complete safety instructions of the drive. Ignoring the instructions can cause physical injury or death, or damage to the equipment.



WARNING! Use extreme caution when maneuvering the supply module. It is heavy and have a high center of gravity. Ignoring the following instructions can cause physical injury, or damage to the equipment.

- Wear appropriate safety equipment.
 - Be careful when removing bolts and washers on top of the module not to drop anything inside the module.
 - Use a lifting device:
 - Attach the lifting device securely to the module lifting eyes before removing the module fastening bolts. Keep the lifting device attached to the module until you have lifted the module onto a pallet and made sure that the module is supported and cannot topple over.
 - Lift a replacement module only with a lifting device. Keep the lifting device attached to the module during the work until you are tighten the module fastening bolts.
 - Do not tilt the module. Do not leave the module unattended on a floor.
 - When you push the replacement module into the cabinet, keep your fingers away from the edge of the module edges to avoid pinching them between the module and the cabinet.
-

1. Disconnect the drive from the AC power line and make sure it is safe to start the work. See section [Precautions before electrical work](#) (page 19).
 2. Open the cubicle door.
 3. Remove the shroud.
 4. Unplug the plug connector on top of the module (a), and the plug connector and fiber optic connector in front of the module (b).
 5. Remove the lower support bracket of the module.
 6. Remove the fastening bolts of the DC busbars (a) and the DC busbars carefully. Do not drop anything inside the module. Remove the fastening bolts of the AC busbars (b).
 7. Remove the cooling fan plug connector (a) and the cooling fan (b). See section [Replacing a supply module \(D7T\) cooling fan](#) (page 155).
 8. Remove the side fastening screws of the module on the top (a) and bottom (b).
 9. Attach a lifting device to the lifting eyes of the module (a).
 10. Remove the upper support brackets of the module (a).
 11. Pull the module out of the cabinet carefully. Keep the weight on the lifting device constantly.
 12. Lift the module down onto a pallet.
 13. Keep the lifting chain attached to the module and attach the module safely to the pallet.
 14. Remove the lifting chain from the old module and move the module away.
 15. Install a new module in reverse order.
 16. Close the cubicle door.
-

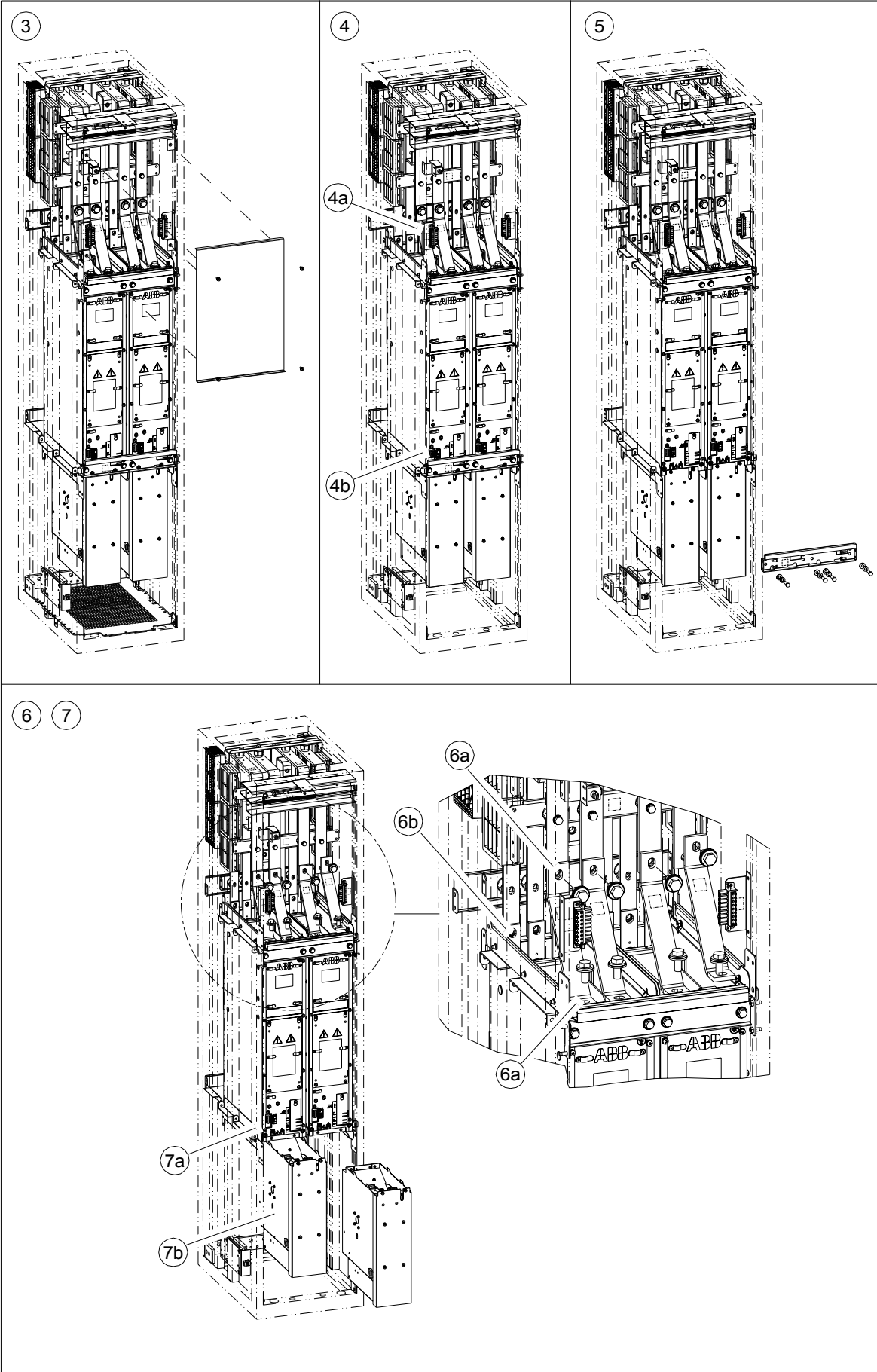

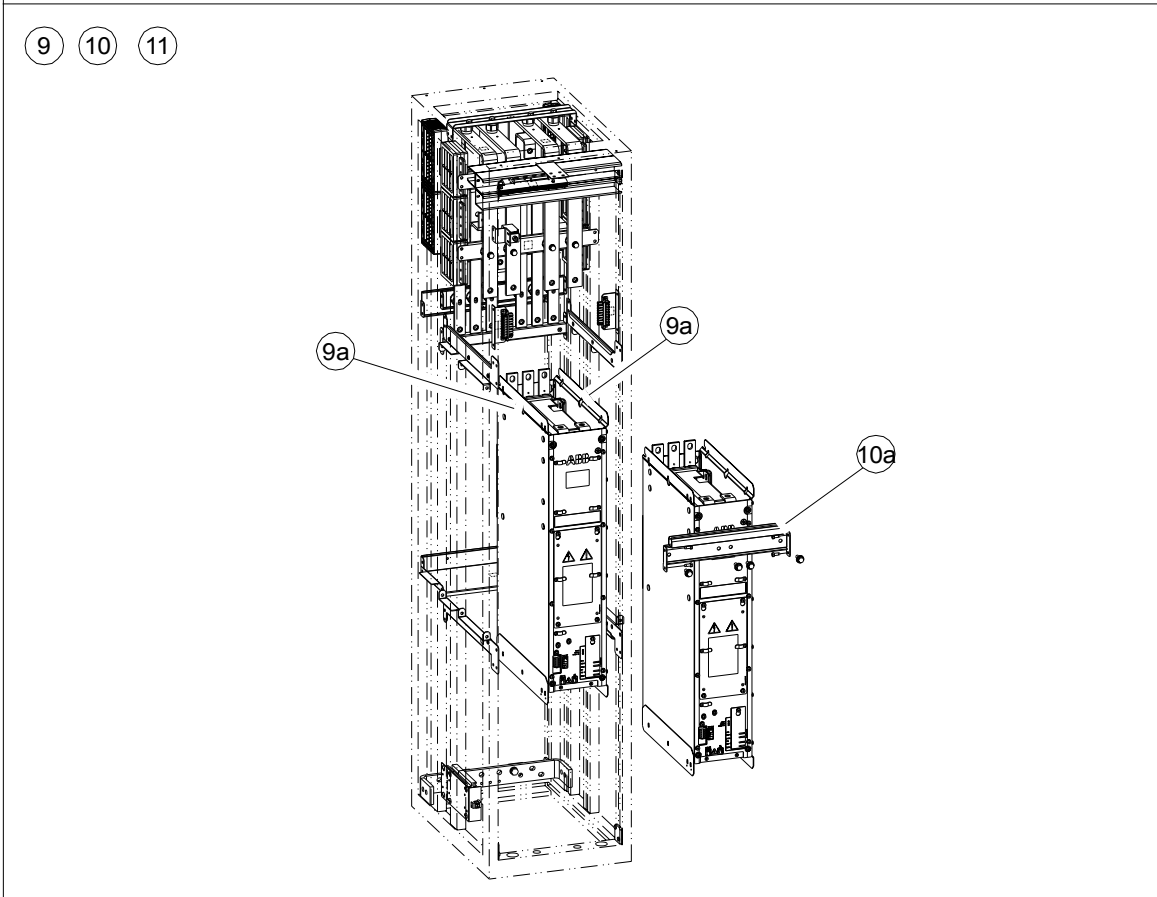
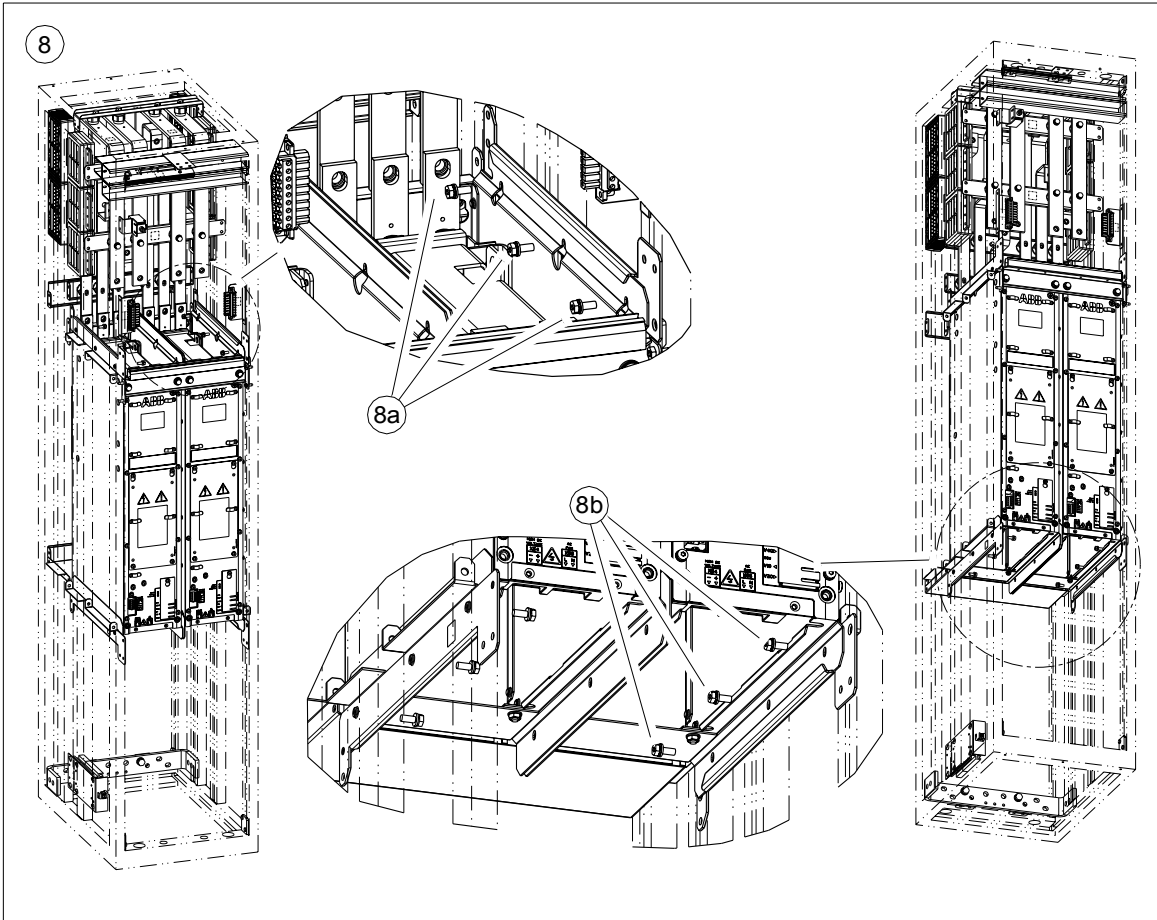

Replacing a frame D8T supply module



WARNING! Ignoring the following instructions can cause physical injury or death, or damage to the equipment:

- Use extreme caution when maneuvering a supply module that runs on wheels. The modules are heavy (approximately 175 kg) and have a high center of gravity. They topple over easily if handled carelessly.
- When removing a module which is equipped with wheels, pull the module carefully out of the cubicle along the extraction/installation ramp. While pulling on the handle, keep a constant pressure with one foot on the base of the module to prevent the module from falling on its back.
- When replacing a module which is equipped with wheels, push the module up the ramp and back into the cubicle. Keep your fingers away from the edge of the module front plate to avoid pinching them between the module and the cubicle. Also, keep a constant pressure with one foot on the base of the module to prevent the module from falling on its back.
- Do not tilt the module. Do not leave the module unattended on a sloping floor.
- Do not use the ramp with plinth heights over 50 mm. The ramp supplied with the drive system is designed for a plinth height of 50 mm (the standard plinth height of ABB cabinets).

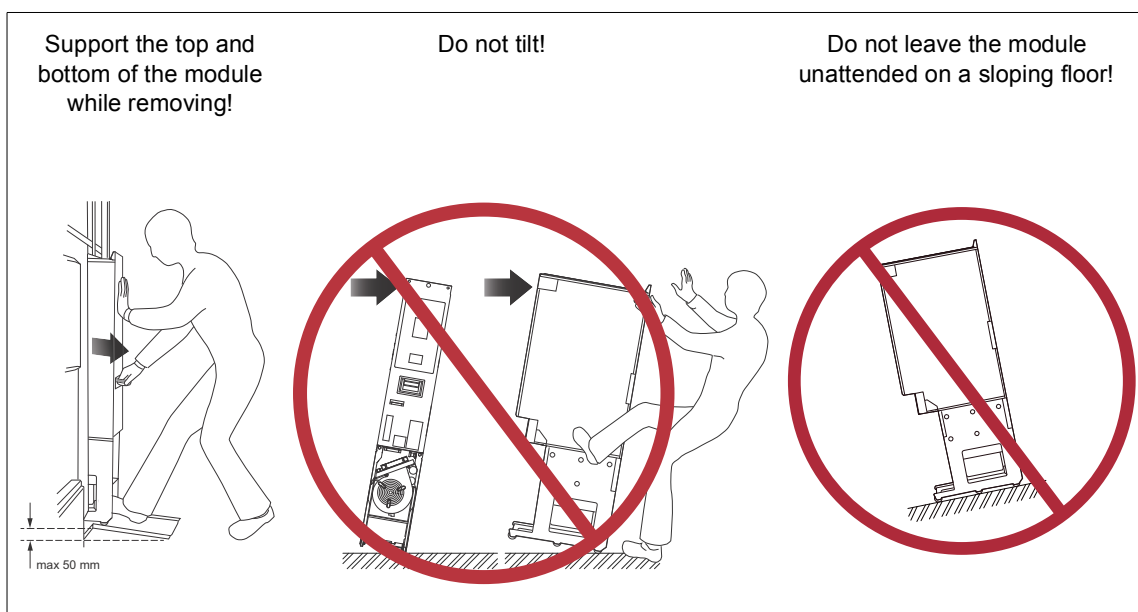

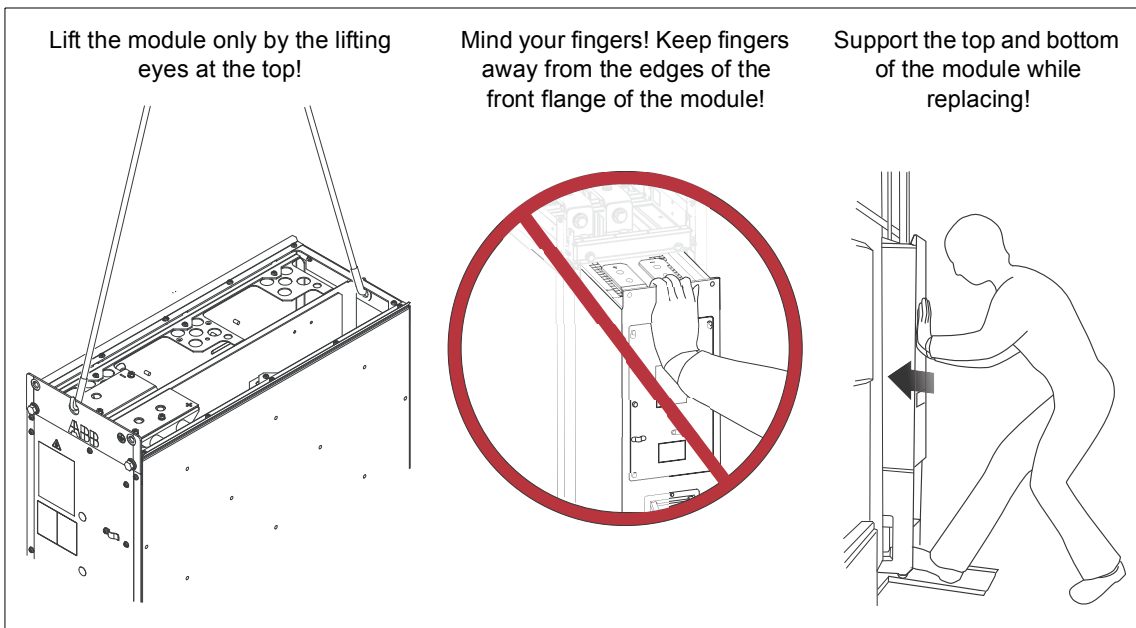

Refer to the drawings below.

1. Stop the drive and do the steps in section [Precautions before electrical work](#) (page 19) before you start the work.
2. Open the door of the supply module cubicle.
3. Undo the screws of the shroud in the upper part of the cubicle. Lift and remove the shroud.
4. Unplug the wires and optic cables from the module, and move them aside.
5. Attach the module extraction/installation ramp (included) to the base of the cabinet so that the tabs on the mounting bracket enter the slots on the ramp.
6. Remove the bolts holding the DC busbars.
7. Remove the module fastening screws at the top of the module.
8. Remove the module fastening screws at the bottom of the module.
9. Pull the module carefully out of the cabinet along the ramp.
10. To reinsert the module into the cubicle:
 - Push the module back in and fasten. Tighten the fastening screws of the module to 22 N·m (16.2 lbf·ft) and the fastening bolts of the DC output busbars to 70 N·m (52 lbf·ft).
 - Reconnect the wires and fiber optic cables to the module.
 - Reinstall the shrouding.
 - Remove the module extraction/installation ramp and close the cubicle door.

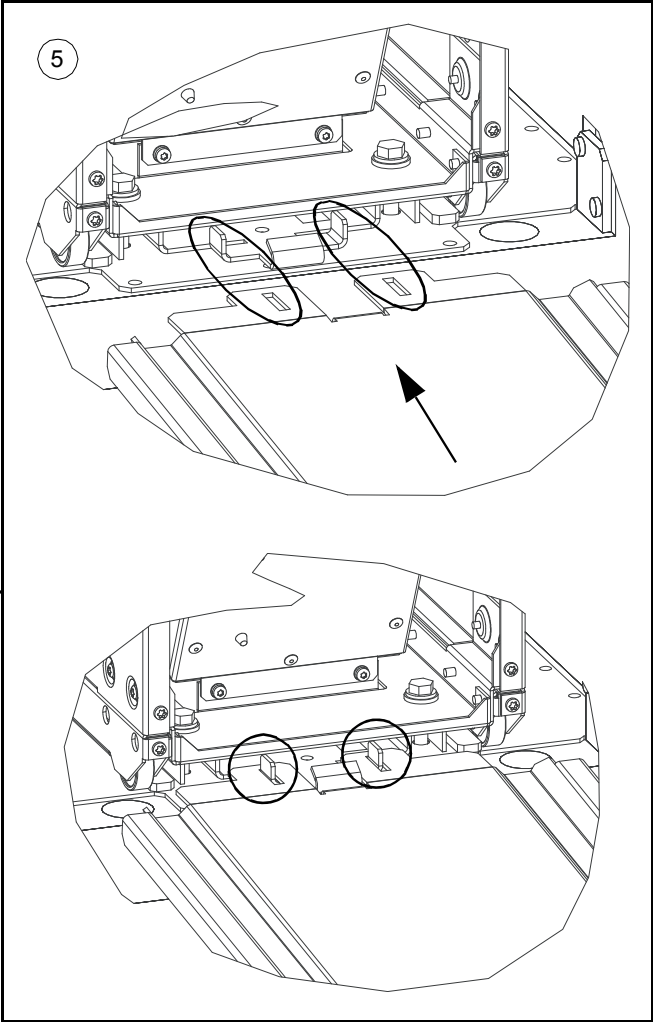
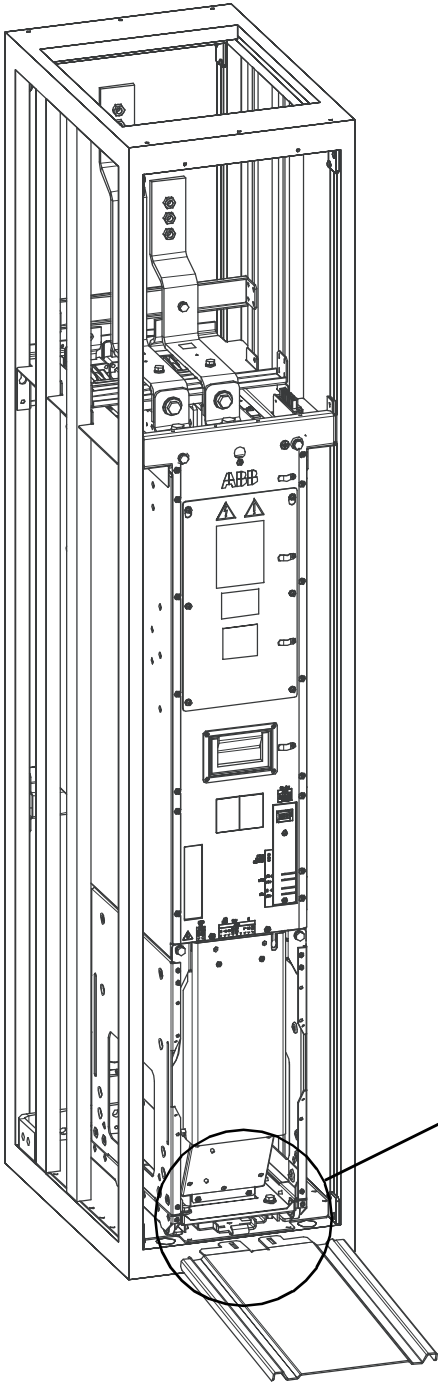

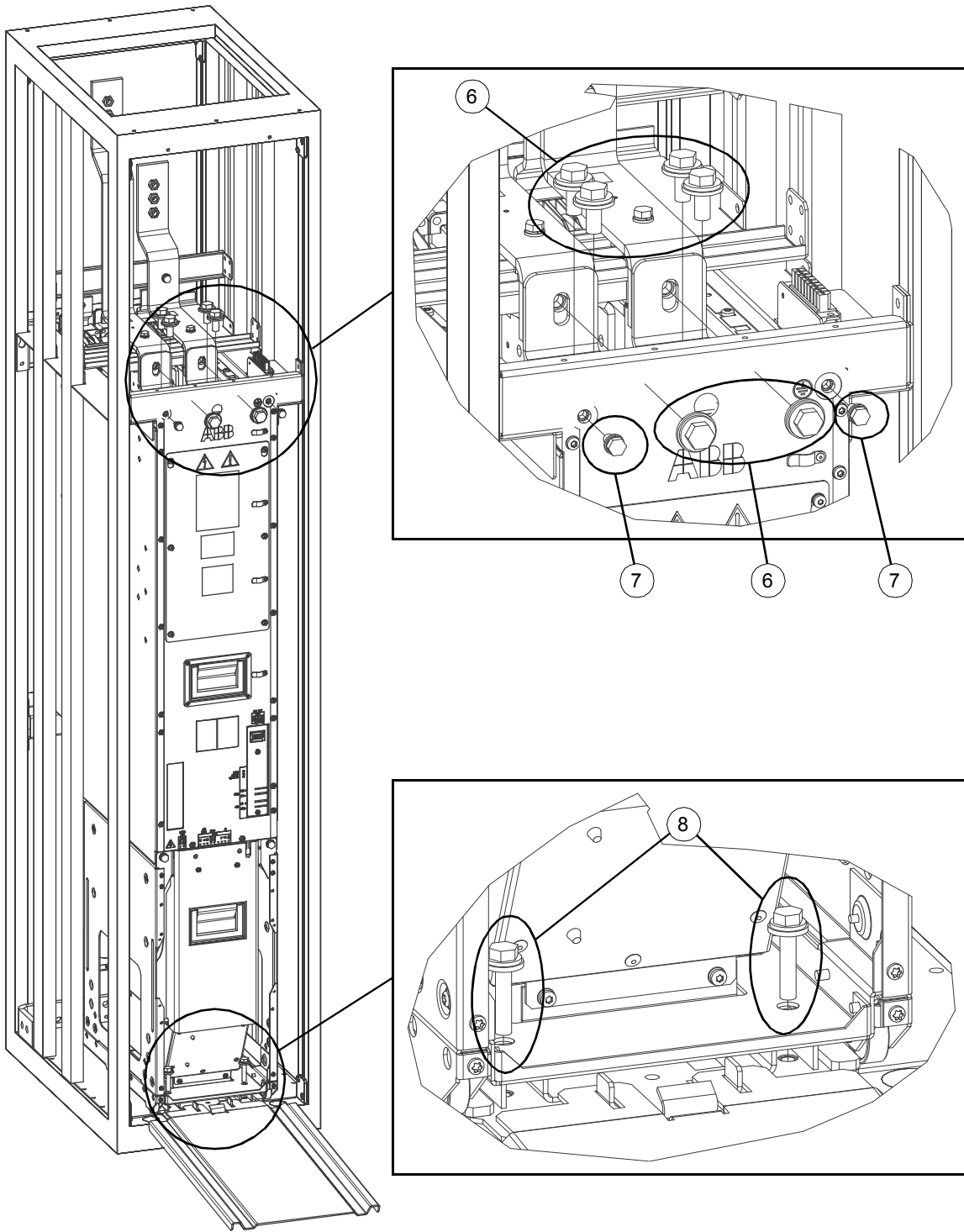

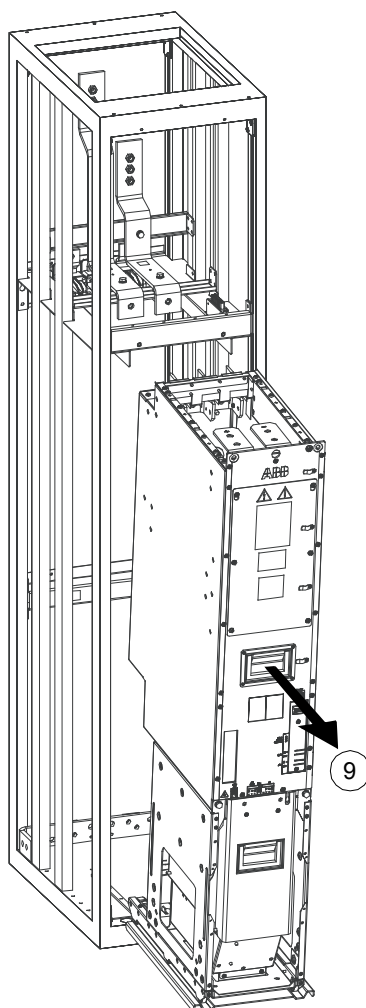

Replacing an inverter module

Follow the module extraction and insertion procedures under [Connecting the motor cables \(units without common motor terminal cubicle or sine output filter\)](#) (page 106).

Reduced run of the inverter unit

A “reduced run” function is available for inverter units consisting of parallel-connected inverter modules. The function makes it possible to continue operation with limited current even if one (or more) module is out of service, for example, because of maintenance work. In principle, reduced run is possible with only one module, but the physical requirements of operating the motor still apply; for example, the modules remaining in use must be able to provide the motor with enough magnetizing current.

■ Activation of the reduced run function



WARNING! Obey the instructions in chapter [Safety instructions](#). If you ignore them, injury or death, or damage to the equipment can occur.

Refer to the drawing below.

1. Stop the drive and do the steps in section [Precautions before electrical work](#) (page 19) before you start the work.
 2. Remove the shrouding above the module bay (in front of the DC fuses).
 3. Remove the DC fuses and the busbar assembly connecting the fuses to the inverter module. Store these parts – they are to be reinstalled only with the inverter module. Make note of the order of washers.
 4. Remove the faulty module from its bay according to the instructions on page 108.
 5. Install the air baffle (included) to the underside of the top module guide:
 - Fasten the front edge of the baffle to the module mounting holes using the module mounting screws (2 × M8). Tighten to 9 N·m (6.6 lbf·ft).
 - Fasten the left/right sides of the baffle if wherever possible using M4 screws. (This depends on the location of the module in the cubicle.) Tighten to 1...2 N·m (0.7 ... 1.5 lbf·ft).
-

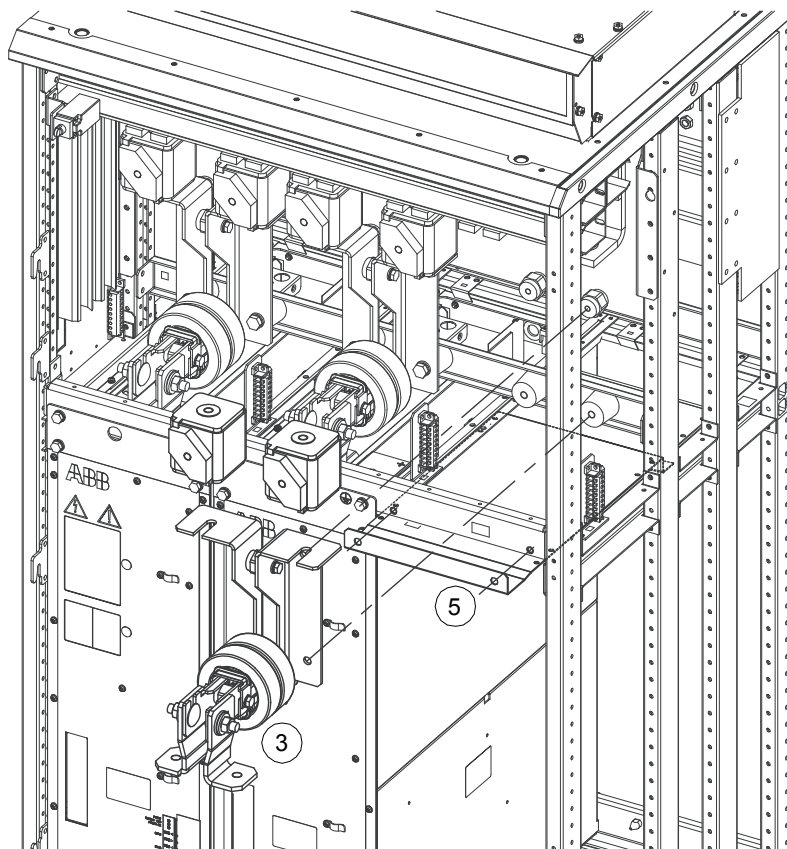

6. If the inverter control unit (A41) is powered from the faulty module, connect the power supply wiring using the extension wire set included to another module.
7. If the Safe torque off (STO) function is in use, install the jumper wire set included in the STO wiring in place of the missing module. (This is not needed if the module was the last on the STO wire chain.)
8. Reinstall all shrouding removed earlier. **Note:** Do not reinstall the DC fuses or busbars but store them elsewhere until the module can be reinstalled.
9. Switch on the power to the drive.
10. Enter the number of inverter modules present into parameter *95.13 Reduced run mode*.
11. Reset all faults and start the drive.
12. If the Safe torque off function is in use, perform an acceptance test as described under [Start-up including acceptance test](#) (page 255).

The maximum current is now automatically limited according to the new inverter configuration. A mismatch between the number of detected modules and the value set in *95.13* will generate a fault.

Returning the module

1. Install the module in reverse order. Use the following tightening torques:
 - DC busbar assembly to upper insulators (2 × M8): 9 N·m (6.6 lbf·ft)
 - DC busbar assembly to lower insulators (2 × M10): 18 N·m (13.3 lbf·ft)
 - Fuses to DC busbars: 50 N·m (37 lbf·ft) (Bussmann), 46 N·m (34 lbf·ft) (Mersen/Ferraz-Shawmut)
 - Module to cabinet frame (4 × M8): 22 N·m (16 lbf·ft)
 - DC busbar assembly to module DC input (2 × M12): 70 N·m (52 lbf·ft)
 2. Restore the original wiring (STO and control unit power supply whenever needed).
 3. Set parameter 95.13 to 0 to disable the reduced run function.
 4. Perform an acceptance test as described under [Start-up including acceptance test](#) (page 255).
-

Fuses

■ Replacing the AC fuses

Frame 1×D8T + 2×R8i and 2×D7T + 2×R8i drives have AC fuses installed in the incoming cubicle(s) (ICU) only.

Frame 2×D8T + 2×R8i and above have AC fuses at the input of each supply module. These fuses are fitted above the modules in the supply module cubicle(s). In addition, frame 2×D8T + n×R8i drives with option +F250 (main contactor) have “common” AC fuses installed in the incoming cubicle.

The drawings below show the replacement of the AC fuses inside a supply module cubicle. The AC fuses in the incoming cubicle can be replaced following the same procedure.



WARNING! Obey the instructions in chapter [Safety instructions](#). If you ignore them, injury or death, or damage to the equipment can occur.

1. Do the steps in section [Precautions before electrical work](#) on page 19 before you start the work.
 2. Open the door of the supply module (or incoming) cubicle.
 3. Remove the shrouding from in front of the fuses.
 4. Slacken the nuts of the headless screws of the fuses so that you can slide out the fuse blocks. Make note of the order of the washers on the screws.
 5. Remove the screws, nuts and washers from the old fuses and attach them to the new fuses. Make sure to keep the washers in the original order.
 6. Insert the new fuses into their slots in the cubicle.
 7. Tighten the nuts to torque as follows:
 - Bussmann fuses: 50 N·m (37 lbf·ft)
 - Mersen (Ferraz-Shawmut) fuses: 46 N·m (34 lbf·ft)
 - Other: Refer to the fuse manufacturer’s instructions.
 8. Reinstall the shrouding removed earlier and close the cubicle door.
-

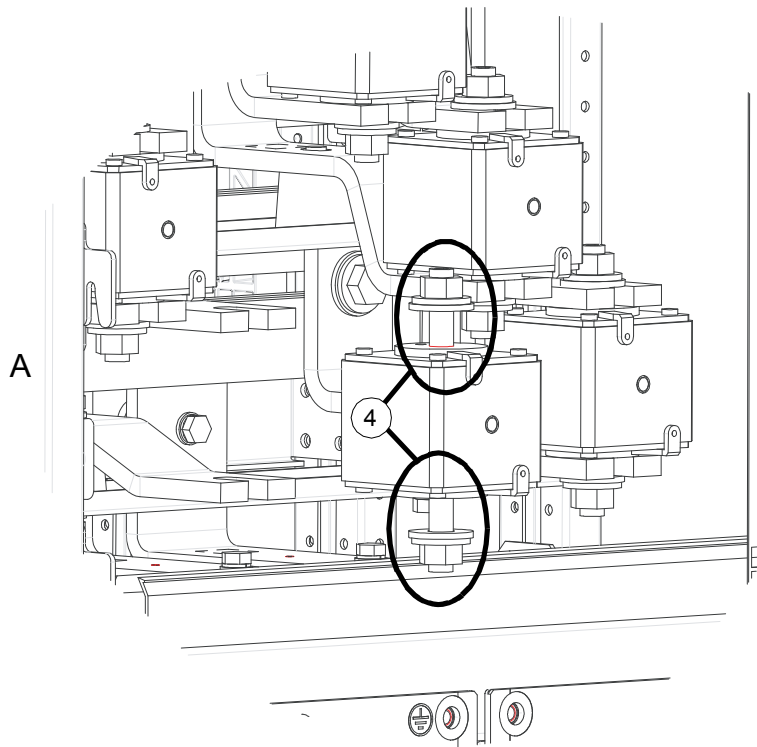
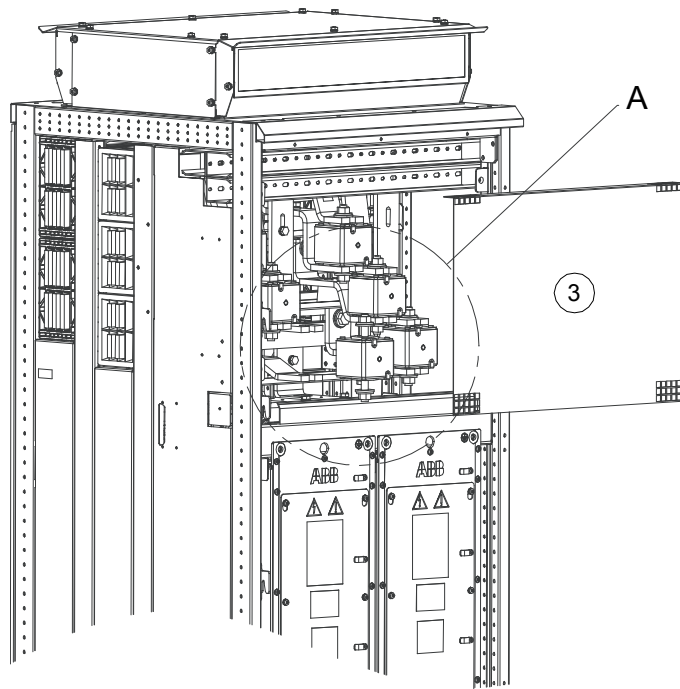

■ Replacing the DC fuses in the inverter module cubicle

Each inverter module has DC fuses fitted above the module.

Refer to the drawing below.



WARNING! Obey the instructions in chapter [Safety instructions](#). If you ignore them, injury or death, or damage to the equipment can occur.

1. Do the steps in section [Precautions before electrical work](#) on page 19 before you start the work.
2. Open the door of the inverter module cubicle.
3. Remove the shrouding from in front of the fuses.
4. Slacken the nuts of the headless screws of the fuses so that you can slide out the fuse blocks. Make note of the order of the washers on the screws.
5. Remove the screws, nuts and washers from the old fuses and attach them to the new fuses. Make sure to keep the washers in the original order.
6. Insert the new fuses into their slots in the cubicle.
7. Tighten the nuts to torque as follows:
 - Bussmann fuses: 50 N·m (37 lbf·ft)
 - Mersen (Ferraz-Shawmut) fuses: 46 N·m (34 lbf·ft)
 - Other: Refer to the fuse manufacturer's instructions.
8. Reinstall the shrouding removed earlier and close the cubicle door.

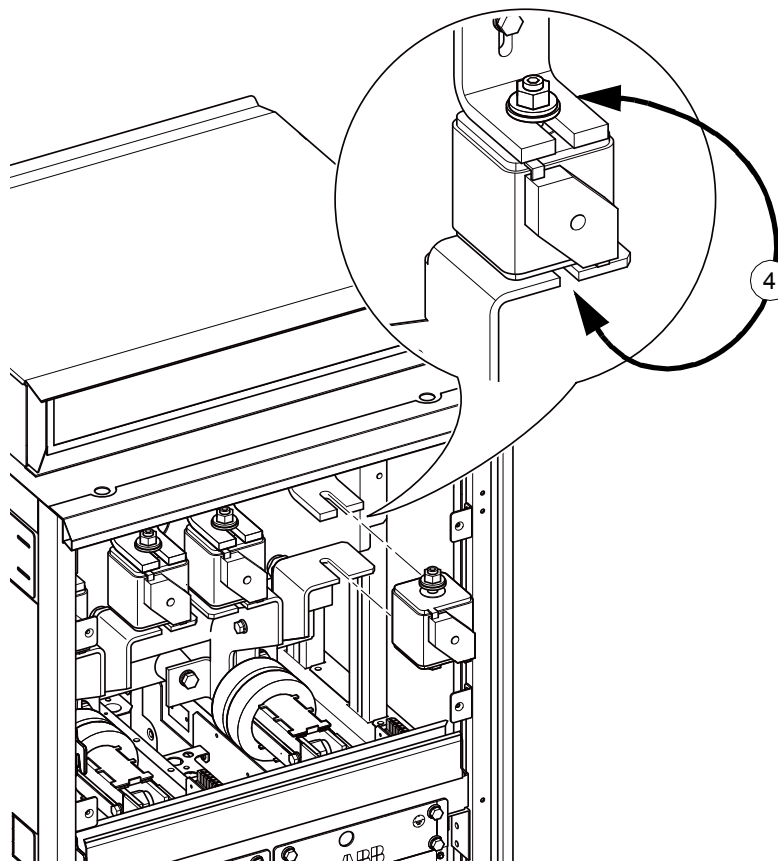

■ Replacing the supply module DC fuses

The supply modules have internal DC fuses. Refer to the drawing below.



WARNING! Obey the instructions in chapter [Safety instructions](#). If you ignore them, injury or death, or damage to the equipment can occur.

1. Do the steps in section [Precautions before electrical work](#) on page 19 before you start the work.
2. Open the door of the supply module cubicle.
3. Move aside any wiring run across the fuse compartment cover.
4. Slacken the two top screws of the fuse compartment cover. Remove the remaining screws. Lift the cover somewhat so you can remove it.
5. Check the condition of the fuses and replace if necessary. Use the tightening torque specified by the fuse manufacturer.
6. Reinstall the cover removed earlier and close the cubicle door.

D7T

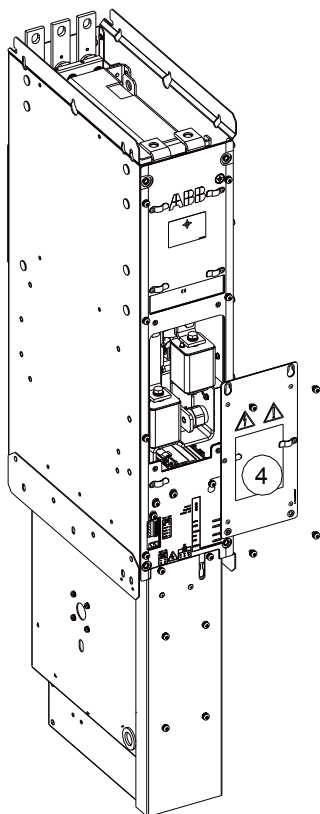

D8T

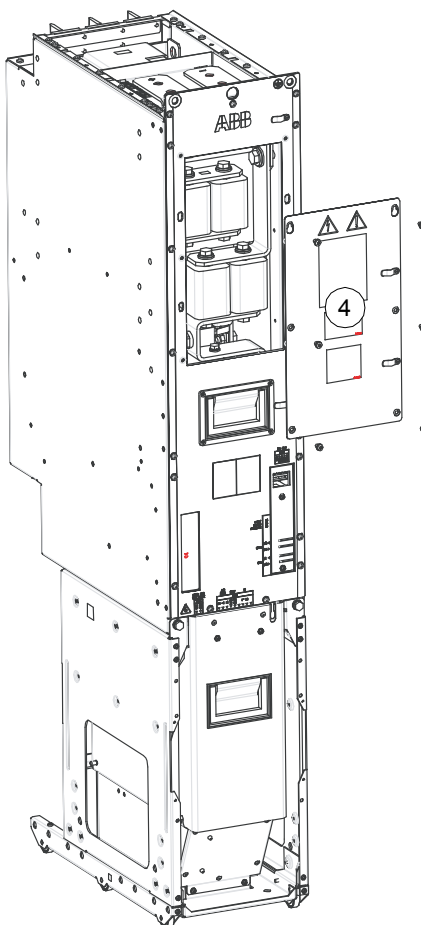

Capacitors

The DC circuit of the power modules of the drive contain several electrolytic capacitors. Their lifespan depends on the operating time of the drive, loading and ambient temperature. Capacitor life can be prolonged by lowering the ambient temperature.

Capacitor failure is usually followed by damage to the unit and an input cable fuse failure, or a fault trip. Contact ABB if capacitor failure is suspected. Replacements are available from ABB. Do not use other than ABB specified spare parts.

■ Reforming the capacitors

The capacitors must be reformed if the drive has been stored for a year or more. See page [53](#) for information on finding out the manufacturing date. For information on reforming the capacitors, see *Converter module capacitor reforming instructions* (3BFE64059629 [English]).

Control panel

■ Replacing the battery

1. Turn the lid on the back of the panel counter-clockwise until the lid opens.
2. Replace the battery with a new CR2032 battery.
3. Put the lid back and tighten it by turning it clockwise.
4. Dispose of the old battery according to local disposal rules or applicable laws.



■ Cleaning

See *ACS-AP-x assistant control panels user's manual* [3AUA0000085685 (English)].

Control units

BCU control unit types

There are three variants of the BCU control unit used in ACS880 drives: BCU-02, BCU-12 and BCU-22. These have a different number of converter module connections (2, 7 and 12 respectively) but are otherwise identical. The three BCU types are interchangeable as long as the number of connections is sufficient. For example, the BCU-22 can be used as a direct replacement for both BCU-02 and BCU-12.

Memory unit

After replacing a supply or inverter control unit, the existing parameter settings can be retained by transferring the memory unit from the defective control unit to the new control unit.



WARNING! Do not remove or insert the memory unit when the control unit is powered.



WARNING! Obey the instructions in chapter [Safety instructions](#). If you ignore them, injury or death, or damage to the equipment can occur.

1. Do the steps in section [Precautions before electrical work](#) (page 19) before you start the work.
2. Make sure that the control unit is not powered.
3. Undo the fastening screw and pull the memory unit out.
4. Install a memory unit in reverse order.

One end of the BCU control unit

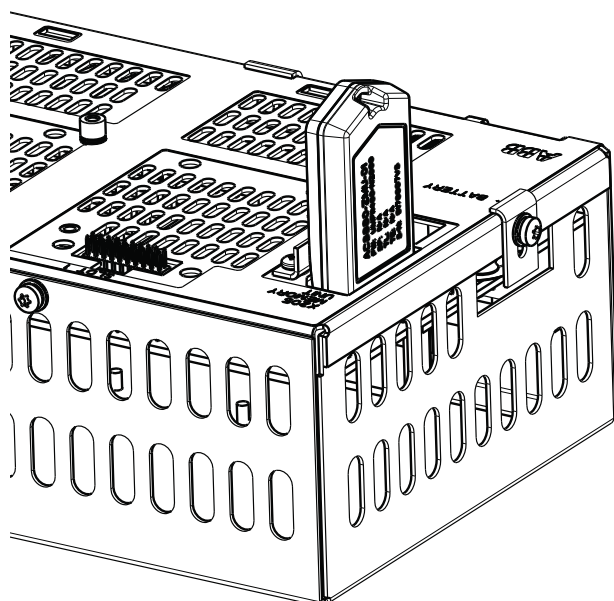

■ Control unit battery

Replace the real-time clock battery if the BATT OK LED is not illuminated when the control unit is powered. For information on the LED, see [Control unit layout and connections](#) (page 128).

1. Do the steps in section [Precautions before electrical work](#) (page 19) before you start the work.
2. Undo the fastening screw and remove the battery
3. Replace the battery with a new BR2032 battery.
4. Dispose of the old battery according to local disposal rules or applicable laws.
5. Set the real-time clock.

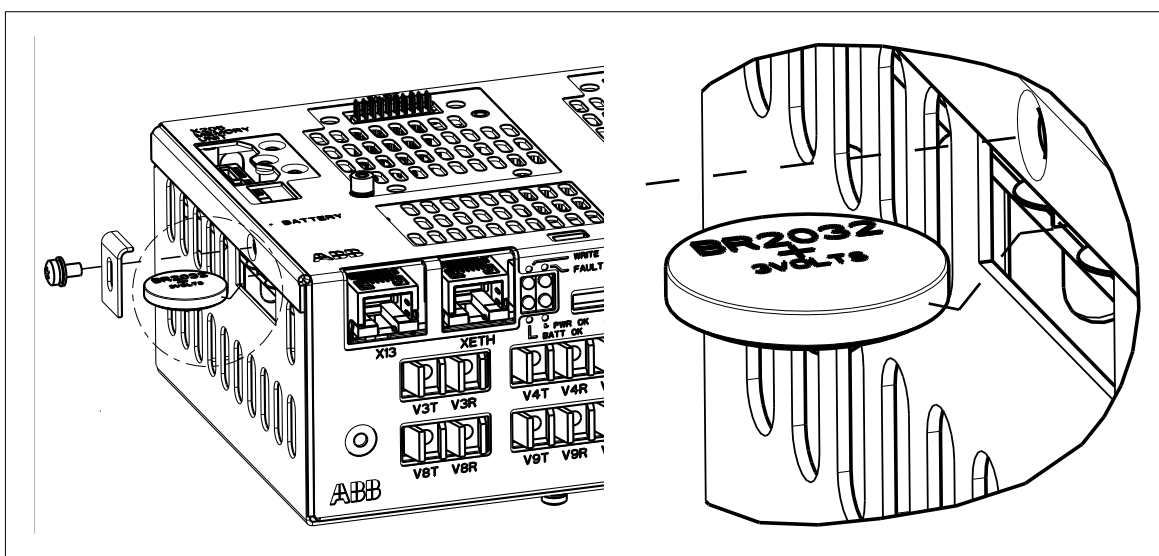



12

Technical data

Contents of this chapter

This chapter contains the technical specifications of the drive, for example, the ratings, fuse data, sizes and technical requirements, provisions for fulfilling the requirements for CE and other markings.

Ratings

The nominal ratings for the drives with 50 Hz and 60 Hz supply are given below. The symbols are described below the table.

Drive type	Nominal ratings					Output ratings					
						Light-overload use			Heavy-duty use		
	I_N	I_{max}	P_N		S_N	I_{Ld}	P_{Ld}		I_{Hd}	P_{Hd}	
A	A	kW	hp	kVA	A	kW	hp	A	kW	hp	
$U_N = 400\text{ V}$											
ACS880-07-1140A-3	1140	1482	630	–	790	1072	560	–	787	400	–
ACS880-07-1250A-3	1250	1630	710	–	866	1200	630	–	935	500	–
ACS880-07-1480A-3	1480	1930	800	–	1025	1421	800	–	1107	630	–
ACS880-07-1760A-3	1760	2120	1000	–	1219	1690	900	–	1316	710	–
ACS880-07-2210A-3	2210	2880	1200	–	1531	2122	1200	–	1653	900	–
ACS880-07-2610A-3	2610	3140	1400	–	1808	2506	1400	–	1952	1000	–

Drive type	Nominal ratings					Output ratings					
						Light-overload use			Heavy-duty use		
	I_N	I_{max}	P_N		S_N	I_{Ld}	P_{Ld}		I_{Hd}	P_{Hd}	
	A	A	kW	hp	kVA	A	kW	hp	A	kW	hp
$U_N = 400\text{ V}$, 12-pulse connection											
ACS880-07-0990A-3+A004	990	1287	560	–	686	950	500	–	741	400	–
ACS880-07-1140A-3+A004	1140	1482	630	–	790	1094	560	–	853	450	–
ACS880-07-1250A-3+A004	1250	1630	710	–	866	1200	630	–	935	500	–
ACS880-07-1480A-3+A004	1480	1930	800	–	1025	1421	800	–	1107	630	–
ACS880-07-1760A-3+A004	1760	2120	1000	–	1219	1690	900	–	1316	710	–
ACS880-07-2210A-3+A004	2210	2880	1200	–	1531	2122	1200	–	1653	900	–
ACS880-07-2610A-3+A004	2610	3140	1400	–	1808	2506	1400	–	1952	1000	–
$U_N = 500\text{ V}$											
ACS880-07-1070A-5	1070	1391	710	900	927	1027	710	900	800	560	700
ACS880-07-1320A-5	1320	1716	900	1000	1143	1267	900	1000	987	710	900
ACS880-07-1450A-5	1450	1890	1000	1250	1256	1392	900	1200	1085	710	900
ACS880-07-1580A-5	1580	2060	1100	1400	1368	1517	1000	1250	1182	800	1000
ACS880-07-1800A-5	1800	2340	1250	1600	1559	1728	1200	1500	1346	900	1100
ACS880-07-1980A-5	1980	2574	1400	1750	1715	1901	1300	1500	1481	1000	1250
$U_N = 500\text{ V}$, 12-pulse connection											
ACS880-07-0990A-5+A004	990	1287	710	900	857	950	630	800	741	500	600
ACS880-07-1320A-5+A004	1320	1716	900	1000	1143	1267	900	1000	987	710	900
ACS880-07-1450A-5+A004	1450	1890	1000	1250	1256	1392	900	1200	1085	710	900
ACS880-07-1580A-5+A004	1580	2060	1100	1400	1368	1517	1000	1250	1182	800	1000
ACS880-07-1800A-5+A004	1800	2340	1250	1600	1559	1728	1200	1500	1346	900	1100
ACS880-07-1980A-5+A004	1980	2574	1400	1750	1715	1901	1300	1500	1481	1000	1250
$U_N = 690\text{ V}$											
ACS880-07-0800A-7	800	1200	800	900	956	768	710	800	598	560	600
ACS880-07-0900A-7	900	1350	900	1000	1076	864	800	900	673	630	700
ACS880-07-1160A-7	1160	1740	1100	1250	1386	1114	1100	1250	868	800	900
ACS880-07-1450A-7	1450	2175	1400	1600	1733	1392	1250	1500	1085	1000	1100
ACS880-07-1650A-7	1650	2475	1600	1750	1972	1584	1500	1750	1234	1200	1250
ACS880-07-1950A-7	1950	2925	1900	2000	2330	1872	1800	2000	1459	1400	1500
ACS880-07-2300A-7	2300	3450	2200	2500	2749	2208	2000	2250	1720	1600	1750
ACS880-07-2600A-7	2600	3900	2500	2800	3107	2496	2400	2700	1945	1900	2000
ACS880-07-2860A-7	2860	4290	2800	3100	3418	2746	2600	2900	2139	2000	2250
$U_N = 690\text{ V}$, 12-pulse connection											
ACS880-07-0800A-7+A004	800	1200	800	900	956	768	710	800	598	560	600
ACS880-07-0950A-7+A004	950	1425	900	1000	1135	912	800	900	711	630	700
ACS880-07-1160A-7+A004	1160	1740	1100	1250	1386	1114	1100	1250	868	800	900
ACS880-07-1450A-7+A004	1450	2175	1400	1600	1733	1392	1250	1500	1085	1000	1100
ACS880-07-1650A-7+A004	1650	2475	1600	1750	1972	1584	1500	1750	1234	1200	1250
ACS880-07-1950A-7+A004	1950	2925	1900	2000	2330	1872	1800	2000	1459	1400	1500
ACS880-07-2300A-7+A004	2300	3450	2200	2500	2749	2208	2000	2250	1720	1600	1750
ACS880-07-2600A-7+A004	2600	3900	2500	2800	3107	2496	2400	2700	1945	1900	2000
ACS880-07-2860A-7+A004	2860	4290	2800	3100	3418	2746	2400	2900	2139	2000	2250

■ Definitions

U_N	Supply voltage range. See also section Electrical power network specification (page 189).
I_N	Nominal output current (available continuously with no over-loading)
I_{max}	Maximum output current. Available for 10 seconds at start, then as long as allowed by drive temperature.
P_N	Typical motor power in no-overload use. The horsepower ratings are typical NEMA motor sizes at 460 V (ACS880-07-xxxxA-5) and 575 V (ACS880-07-xxxxA-7) respectively.
S_N	Apparent power in no-overload use.
I_{Ld}	Continuous rms output current allowing 10% overload for 1 minute every 5 minutes.
P_{Ld}	Typical motor power in light-overload use
I_{Hd}	Continuous rms output current allowing 50% overload for 1 minute every 5 minutes.
P_{Hd}	Typical motor power in heavy-duty use

Note 1: The ratings apply at an ambient temperature of 40 °C (104 °F).

Note 2: To achieve the rated motor power given in the table, the rated current of the drive must be higher than or equal to the rated motor current.

The DriveSize dimensioning tool available from ABB is recommended for selecting the drive, motor and gear combination.

■ Derating

Ambient temperature derating

In the temperature range +40...50 °C (+104...122 °F), the rated output current is derated by 1% for every added 1 °C (1.8 °F). The output current can be calculated by multiplying the current given in the rating table by the derating factor (k):

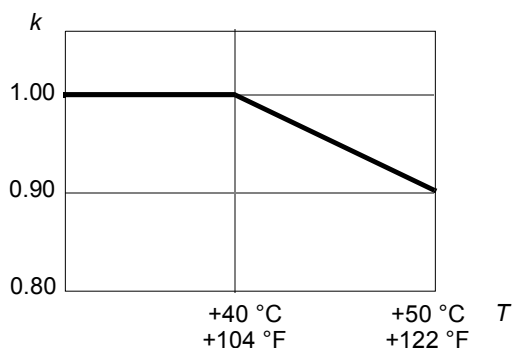

Altitude derating

At altitudes from 1000 to 4000 m (3300 to 13123 ft) above sea level, the derating is 1% for every 100 m (328 ft). If ambient temperature is below +40 °C (+104 °F), the derating can be reduced by 1.5% for every 1 °C reduction in temperature. For a more accurate derating, use the DriveSize PC tool. A few altitude derating curves are shown below.

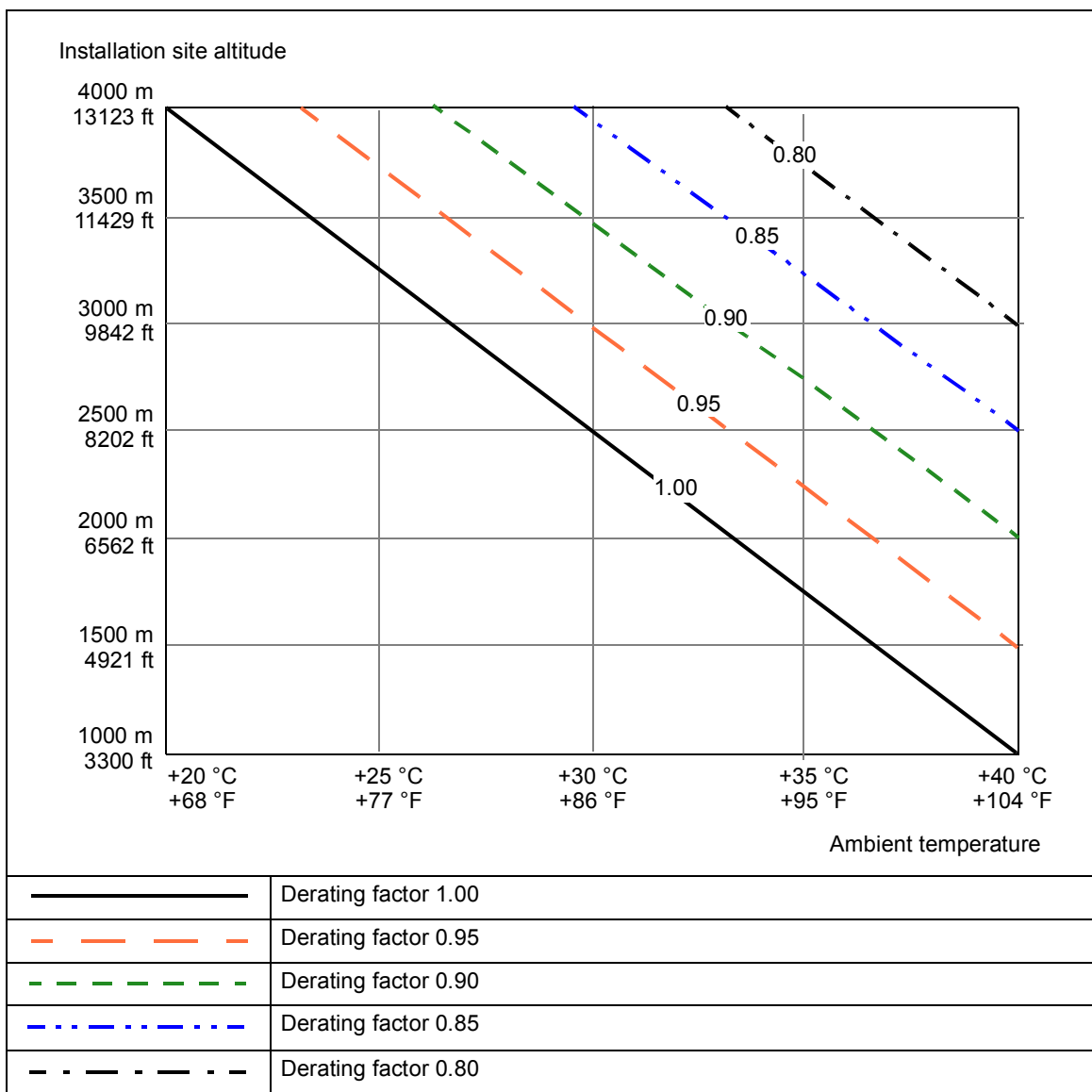

Switching frequency derating

Switching frequencies other than default can require output current derating. Contact ABB for more information.

Output frequency derating

Motor operation above 150 Hz can require type-specific output current derating. Contact ABB for more information.

Frame sizes and power module types

Drive type	Frame size	Supply module(s) used		Inverter modules used	
		Qty	Type	Qty	Type
U_N = 400 V					
ACS880-07-1140A-3	1×D8T + 2×R8i	1	ACS880-304-0980A-3+A018	2	ACS880-104-0640A-3
ACS880-07-1250A-3	2×D8T + 2×R8i	2	ACS880-304-0650A-3+A018	2	ACS880-104-0640A-3
ACS880-07-1480A-3	2×D8T + 2×R8i	2	ACS880-304-0980A-3+A018	2	ACS880-104-0760A-3
ACS880-07-1760A-3	2×D8T + 2×R8i	2	ACS880-304-0980A-3+A018	2	ACS880-104-0900A-3

Drive type	Frame size	Supply module(s) used		Inverter modules used	
		Qty	Type	Qty	Type
ACS880-07-2210A-3	3×D8T + 3×R8i	3	ACS880-304-0980A-3+A018	3	ACS880-104-0760A-3
ACS880-07-2610A-3	3×D8T + 3×R8i	3	ACS880-304-0980A-3+A018	3	ACS880-104-0900A-3
$U_N = 400\text{ V}$, 12-pulse connection					
ACS880-07-0990A-3+A004	2×D7T + 2×R8i	2	ACS880-304-0490A-3+A018	2	ACS880-104-0640A-3
ACS880-07-1140A-3+A004	2×D8T + 2×R8i	2	ACS880-304-0650A-3+A018	2	ACS880-104-0640A-3
ACS880-07-1250A-3+A004	2×D8T + 2×R8i	2	ACS880-304-0650A-3+A018	2	ACS880-104-0640A-3
ACS880-07-1480A-3+A004	2×D8T + 2×R8i	2	ACS880-304-0980A-3+A018	2	ACS880-104-0760A-3
ACS880-07-1760A-3+A004	2×D8T + 2×R8i	2	ACS880-304-0980A-3+A018	2	ACS880-104-0900A-3
ACS880-07-2210A-3+A004	4×D8T + 3×R8i	4	ACS880-304-0650A-3+A018	3	ACS880-104-0760A-3
ACS880-07-2610A-3+A004	4×D8T + 3×R8i	4	ACS880-304-0650A-3+A018	3	ACS880-104-0900A-3
$U_N = 500\text{ V}$					
ACS880-07-1070A-5	1×D8T + 2×R8i	1	ACS880-304-0980A-5+A018	2	ACS880-104-0590A-5
ACS880-07-1320A-5	2×D8T + 2×R8i	2	ACS880-304-0650A-5+A018	2	ACS880-104-0740A-5
ACS880-07-1450A-5	2×D8T + 2×R8i	2	ACS880-304-0980A-5+A018	2	ACS880-104-0740A-5
ACS880-07-1580A-5	2×D8T + 2×R8i	2	ACS880-304-0980A-5+A018	2	ACS880-104-0810A-5
ACS880-07-1800A-5	2×D8T + 3×R8i	2	ACS880-304-0980A-5+A018	3	ACS880-104-0740A-5
ACS880-07-1980A-5	2×D8T + 3×R8i	2	ACS880-304-0980A-5+A018	3	ACS880-104-0810A-5
$U_N = 500\text{ V}$, 12-pulse connection					
ACS880-07-0990A-5+A004	2×D7T + 2×R8i	2	ACS880-304-0490A-5+A018	2	ACS880-104-0590A-5
ACS880-07-1320A-5+A004	2×D8T + 2×R8i	2	ACS880-304-0650A-5+A018	2	ACS880-104-0740A-5
ACS880-07-1450A-5+A004	2×D8T + 2×R8i	2	ACS880-304-0980A-5+A018	2	ACS880-104-0740A-5
ACS880-07-1580A-5+A004	2×D8T + 2×R8i	2	ACS880-304-0980A-5+A018	2	ACS880-104-0810A-5
ACS880-07-1800A-5+A004	2×D8T + 3×R8i	2	ACS880-304-0980A-5+A018	3	ACS880-104-0740A-5
ACS880-07-1980A-5+A004	2×D8T + 3×R8i	2	ACS880-304-0980A-5+A018	3	ACS880-104-0810A-5
$U_N = 690\text{ V}$					
ACS880-07-0800A-7	1×D8T + 2×R8i	1	ACS880-304-0820A-7+A018	2	ACS880-104-0410A-7
ACS880-07-0900A-7	1×D8T + 2×R8i	1	ACS880-304-0820A-7+A018	2	ACS880-104-0530A-7
ACS880-07-1160A-7	2×D8T + 2×R8i	2	ACS880-304-0570A-7+A018	2	ACS880-104-0600A-7
ACS880-07-1450A-7	2×D8T + 3×R8i	2	ACS880-304-0820A-7+A018	3	ACS880-104-0530A-7
ACS880-07-1650A-7	2×D8T + 3×R8i	2	ACS880-304-0820A-7+A018	3	ACS880-104-0600A-7
ACS880-07-1950A-7	3×D8T + 4×R8i	3	ACS880-304-0820A-7+A018	4	ACS880-104-0600A-7
ACS880-07-2300A-7	3×D8T + 4×R8i	3	ACS880-304-0820A-7+A018	4	ACS880-104-0600A-7
ACS880-07-2600A-7	4×D8T + 5×R8i	4	ACS880-304-0820A-7+A018	5	ACS880-104-0600A-7
ACS880-07-2860A-7	4×D8T + 5×R8i	4	ACS880-304-0820A-7+A018	5	ACS880-104-0600A-7
$U_N = 690\text{ V}$, 12-pulse connection					
ACS880-07-0800A-7+A004	2×D7T + 2×R8i	2	ACS880-304-0410A-7+A018	2	ACS880-104-0410A-7
ACS880-07-0950A-7+A004	2×D8T + 2×R8i	2	ACS880-304-0570A-7+A018	2	ACS880-104-0530A-7
ACS880-07-1160A-7+A004	2×D8T + 2×R8i	2	ACS880-304-0570A-7+A018	2	ACS880-104-0600A-7
ACS880-07-1450A-7+A004	2×D8T + 3×R8i	2	ACS880-304-0820A-7+A018	3	ACS880-104-0530A-7
ACS880-07-1650A-7+A004	2×D8T + 3×R8i	2	ACS880-304-0820A-7+A018	3	ACS880-104-0600A-7
ACS880-07-1950A-7+A004	4×D8T + 4×R8i	4	ACS880-304-0570A-7+A018	4	ACS880-104-0600A-7
ACS880-07-2300A-7+A004	4×D8T + 4×R8i	4	ACS880-304-0570A-7+A018	4	ACS880-104-0600A-7
ACS880-07-2600A-7+A004	4×D8T + 5×R8i	4	ACS880-304-0820A-7+A018	5	ACS880-104-0600A-7
ACS880-07-2860A-7+A004	4×D8T + 5×R8i	4	ACS880-304-0820A-7+A018	5	ACS880-104-0600A-7

Fuses

AC fuses

Notes:

- See also [Implementing thermal overload and short-circuit protection](#) on page 87.
- Fuses with higher current rating than the recommended ones must not be used.
- Fuses from other manufacturers can be used if they meet the ratings and the melting curve of the fuse does not exceed the melting curve of the fuse mentioned in the table.

Drive type ACS880-07-	Input current (A)	Ultraprapid (aR) fuses at supply module input					
		Qty	A	A ² s @ 660 V	V	Manufacturer	Type
$U_N = 400\text{ V}$							
1140A-3	1140	3	1600	3900000	690	Bussmann	170M6419
1250A-3	1250	6	1100	1300000	690	Bussmann	170M6415
1480A-3	1480	6	1600	3900000	690	Bussmann	170M6419
1760A-3	1760	6	1600	3900000	690	Bussmann	170M6419
2210A-3	2210	9	1600	3900000	690	Bussmann	170M6419
2610A-3	2610	9	1600	3900000	690	Bussmann	170M6419
$U_N = 400\text{ V, 12-pulse connection}$							
0990A-3+A004	990	6	800	465000	690	Bussmann	170M6412
1140A-3+A004	1140	6	1100	1300000	690	Bussmann	170M6415
1250A-3+A004	1250	6	1100	1300000	690	Bussmann	170M6415
1480A-3+A004	1480	6	1600	3900000	690	Bussmann	170M6419
1760A-3+A004	1760	6	1600	3900000	690	Bussmann	170M6419
2210A-3+A004	2210	12	1100	1300000	690	Bussmann	170M6415
2610A-3+A004	2610	12	1100	1300000	690	Bussmann	170M6415
$U_N = 500\text{ V}$							
1070A-5	1070	3	1600	3900000	690	Bussmann	170M6419
1320A-5	1320	6	1600	3900000	690	Bussmann	170M6419
1450A-5	1450	6	1600	3900000	690	Bussmann	170M6419
1580A-5	1580	6	1600	3900000	690	Bussmann	170M6419
1800A-5	1800	6	1600	3900000	690	Bussmann	170M6419
1980A-5	1980	6	1600	3900000	690	Bussmann	170M6419
$U_N = 500\text{ V, 12-pulse connection}$							
0990A-5+A004	990	6	800	465000	690	Bussmann	170M6412
1320A-5+A004	1320	6	1600	3900000	690	Bussmann	170M6419
1450A-5+A004	1450	6	1600	3900000	690	Bussmann	170M6419
1580A-5+A004	1580	6	1600	3900000	690	Bussmann	170M6419
1800A-5+A004	1800	6	1600	3900000	690	Bussmann	170M6419
1980A-5+A004	1980	6	1600	3900000	690	Bussmann	170M6419

Drive type ACS880-07-	Input current (A)	Ultrarapid (aR) fuses at supply module input					
		Qty	A	A ² s @ 660 V	V	Manufacturer	Type
$U_N = 690\text{ V}$							
0800A-7	800	3	1400	2450000	690	Busmann	170M6417
0900A-7	900	3	1400	2450000	690	Busmann	170M6417
1160A-7	1160	6	1000	945000	690	Busmann	170M6414
1450A-7	1450	6	1400	2450000	690	Busmann	170M6417
1650A-7	1650	6	1400	2450000	690	Busmann	170M6417
1950A-7	1950	9	1400	2450000	690	Busmann	170M6417
2300A-7	2300	9	1400	2450000	690	Busmann	170M6417
2600A-7	2600	12	1400	2450000	690	Busmann	170M6417
2860A-7	2860	12	1400	2450000	690	Busmann	170M6417
$U_N = 690\text{ V, 12-pulse connection}$							
0800A-7+A004	800	6	700	300000	690	Busmann	170M6411
0950A-7+A004	950	6	1000	945000	690	Busmann	170M6414
1160A-7+A004	1160	6	1000	945000	690	Busmann	170M6414
1450A-7+A004	1450	6	1400	2450000	690	Busmann	170M6417
1650A-7+A004	1650	6	1400	2450000	690	Busmann	170M6417
1950A-7+A004	1950	12	1000	945000	690	Busmann	170M6414
2300A-7+A004	2300	12	1000	945000	690	Busmann	170M6414
2600A-7+A004	2600	12	1400	2450000	690	Busmann	170M6417
2860A-7+A004	2860	12	1400	2450000	690	Busmann	170M6417

■ DC fuses at inverter module input

The drive has DC fuses at the input of each inverter module.

Notes:

- Fuses with higher current rating than the recommended ones must not be used.
- Fuses from other manufacturers can be used if they meet the ratings and the melting curve of the fuse does not exceed the melting curve of the fuse mentioned in the table.

Drive type ACS880-07-	DC fuses at inverter module input					
	Qty	A	A ² s	V	Manufacturer	Type
U_N = 400 V						
1140A-3	4	1250	*1950000	690	Bussmann	170M6416
1250A-3	4	1250	*1950000	690	Bussmann	170M6416
1480A-3	4	1400	*2450000	690	Bussmann	170M6417
1760A-3	4	1600	*3900000	690	Bussmann	170M6419
2210A-3	6	1400	*2450000	690	Bussmann	170M6417
2610A-3	6	1600	*3900000	690	Bussmann	170M6419
U_N = 400 V, 12-pulse connection						
0990A-3+A004	4	1250	*1950000	690	Bussmann	170M6416
1140A-3+A004	4	1250	*1950000	690	Bussmann	170M6416
1250A-3+A004	4	1250	*1950000	690	Bussmann	170M6416
1480A-3+A004	4	1400	*2450000	690	Bussmann	170M6417
1760A-3+A004	4	1600	*3900000	690	Bussmann	170M6419
2210A-3+A004	6	1400	*2450000	690	Bussmann	170M6417
2610A-3+A004	6	1600	*3900000	690	Bussmann	170M6419
U_N = 500 V						
1070A-5	4	1100	*1300000	690	Bussmann	170M6415
1320A-5	4	1400	*2450000	690	Bussmann	170M6417
1450A-5	4	1400	*2450000	690	Bussmann	170M6417
1580A-5	4	1400	*2450000	690	Bussmann	170M6417
1800A-5	6	1400	*2450000	690	Bussmann	170M6417
1980A-5	6	1400	*2450000	690	Bussmann	170M6417
U_N = 500 V, 12-pulse connection						
0990A-5+A004	4	1100	*1300000	690	Bussmann	170M6415
1320A-5+A004	4	1400	*2450000	690	Bussmann	170M6417
1450A-5+A004	4	1400	*2450000	690	Bussmann	170M6417
1580A-5+A004	4	1400	*2450000	690	Bussmann	170M6417
1800A-5+A004	6	1400	*2450000	690	Bussmann	170M6417
1980A-5+A004	6	1400	*2450000	690	Bussmann	170M6417
U_N = 690 V						
0800A-7	4	800	**995000	1250	Bussmann	170M6546
0900A-7	4	1000	**2150000	1250	Bussmann	170M6548
1160A-7	4	1100	**2800000	1250	Bussmann	170M6549
1450A-7	6	1000	**2150000	1250	Bussmann	170M6548
1650A-7	6	1100	**2800000	1250	Bussmann	170M6549
1950A-7	8	1100	**2800000	1250	Bussmann	170M6549

Drive type ACS880-07-	DC fuses at inverter module input					
	Qty	A	A ² s	V	Manufacturer	Type
2300A-7	8	1100	**2800000	1250	Bussmann	170M6549
2600A-7	10	1100	**2800000	1250	Bussmann	170M6549
2860A-7	10	1100	**2800000	1250	Bussmann	170M6549
U_N = 690 V, 12-pulse connection						
0800A-7+A004	4	800	**995000	1250	Bussmann	170M6546
0950A-7+A004	4	1000	**2150000	1250	Bussmann	170M6548
1160A-7+A004	4	1100	**2800000	1250	Bussmann	170M6549
1450A-7+A004	6	1000	**2150000	1250	Bussmann	170M6548
1650A-7+A004	6	1100	**2800000	1250	Bussmann	170M6549
1950A-7+A004	8	1100	**2800000	1250	Bussmann	170M6549
2300A-7+A004	8	1100	**2800000	1250	Bussmann	170M6549
2600A-7+A004	10	1100	**2800000	1250	Bussmann	170M6549
2860A-7+A004	10	1100	**2800000	1250	Bussmann	170M6549

*Clearing at 660 V, **Clearing at 1000 V

■ Supply module internal DC fuses

Each supply module has internal DC fuses.

Notes:

- Fuses with higher current rating than the recommended ones must not be used.
- Fuses from other manufacturers can be used if they meet the ratings and the melting curve of the fuse does not exceed the melting curve of the fuse mentioned in the table.

Supply module frame size	DC fuses in each supply module					
	Qty	A	A ² s	V	Manufacturer	Type
D7T	2	700	755000	1000	Bussmann	170M4908
D8T	4	900	*1750000	1100	Bussmann	170M5499

*Clearing at 1000 V

Dimensions and weights

See chapter [Dimensions](#) (page 201).

Free space requirements

Front*		Sides*		Above**	
mm	in.	mm	in.	mm	in.
150	5.91	0	0	400	15.75

*As required by cooling. Also obey the general installation rules given under [Fastening the cabinet to the floor and wall or roof \(non-marine units\)](#) (page 65).

Measured from the base plate of the cabinet top. **Note: 320 mm (12.3 in.) is required for fan replacement of IP54 cabinets.

The diagram illustrates the required clearances for two cabinet types. On the left, an IP22/42 cabinet is shown with a double-headed arrow indicating a clearance of ≥ 400 mm (15.75 in.) above the top of the cabinet. On the right, an IP54 cabinet is shown with a double-headed arrow indicating a clearance of ≥ 320 mm (12.28 in.) above the top of the cabinet. Both cabinets are mounted on a base plate.

Cooling data, noise

Drive type	Air flow		Heat dissipation	Noise
	m ³ /h	ft ³ /min	kW	dB(A)
$U_N = 400$ V				
ACS880-07-1140A-3	4290	2525	18	73
ACS880-07-1250A-3	5720	3367	21	74
ACS880-07-1480A-3	5720	3367	25	74
ACS880-07-1760A-3	5720	3367	29	74
ACS880-07-2210A-3	8580	5050	37	76
ACS880-07-2610A-3	8580	5050	44	76
$U_N = 400$ V, 12-pulse connection				
ACS880-07-0990A-3+A004	5720	3367	15	73
ACS880-07-1140A-3+A004	5720	3367	19	74
ACS880-07-1250A-3+A004	5720	3367	21	74
ACS880-07-1480A-3+A004	5720	3367	25	74
ACS880-07-1760A-3+A004	5720	3367	29	74
ACS880-07-2210A-3+A004	10010	5892	35	76
ACS880-07-2610A-3+A004	10010	5892	44	76
$U_N = 500$ V				
ACS880-07-1070A-5	4290	2525	18	73
ACS880-07-1320A-5	5720	3367	22	74
ACS880-07-1450A-5	5720	3367	25	74
ACS880-07-1580A-5	5720	3367	27	74
ACS880-07-1800A-5	7150	4208	32	75
ACS880-07-1980A-5	7150	4208	36	75

Drive type	Air flow		Heat dissipation	Noise
	m ³ /h	ft ³ /min	kW	dB(A)
$U_N = 500$ V, 12-pulse connection				
ACS880-07-0990A-5+A004	5720	3367	16	73
ACS880-07-1320A-5+A004	5720	3367	22	74
ACS880-07-1450A-5+A004	5720	3367	25	74
ACS880-07-1580A-5+A004	5720	3367	27	74
ACS880-07-1800A-5+A004	7150	4208	32	75
ACS880-07-1980A-5+A004	7150	4208	36	75
$U_N = 690$ V				
ACS880-07-0800A-7	4290	2525	16	73
ACS880-07-0900A-7	4290	2525	20	74
ACS880-07-1160A-7	5720	3367	26	74
ACS880-07-1450A-7	7150	4208	32	75
ACS880-07-1650A-7	7150	4208	36.5	75
ACS880-07-1950A-7	10010	5892	44	76
ACS880-07-2300A-7	10010	5892	52	76
ACS880-07-2600A-7	12870	7575	58	78
ACS880-07-2860A-7	12870	7575	65	78
$U_N = 690$ V, 12-pulse connection				
ACS880-07-0800A-7+A004	5720	3367	16	73
ACS880-07-0950A-7+A004	5720	3367	20	74
ACS880-07-1160A-7+A004	5720	3367	26	74
ACS880-07-1450A-7+A004	7150	4208	32	75
ACS880-07-1650A-7+A004	7150	4208	36.5	75
ACS880-07-1950A-7+A004	11440	6733	44	77
ACS880-07-2300A-7+A004	11440	6733	52	77
ACS880-07-2600A-7+A004	12870	7575	58	78
ACS880-07-2860A-7+A004	12870	7575	65	78

Sine output filter data

Sine output filters are available as option +E206. The table below shows the types and technical data of the filters and filter cubicles used in ACS880-07 drives. The standard filters listed require no current derating.

For availability of sine output filters for other types, contact your local ABB representative.

Drive type ACS880-07-...	Sine filter(s) used		Cooling data		Dimensions	
	Qty	Type	Heat dissipation	Air flow	Width	Weight
			kW	m ³ /h (ft ³ /min)	mm	kg (lbs)
U_N = 400 V						
0990A-3+A004	1	NSIN-1380-6	7	2000 (1180)	1000	750 (1650)
1140A-3	1	NSIN-1380-6	7	2000 (1180)	1000	750 (1650)
1140A-3+A004	1	NSIN-1380-6	7	2000 (1180)	1000	750 (1650)
U_N = 500 V						
0990A-5+A004	1	NSIN-1380-6	7	2000 (1180)	1000	750 (1650)
1070A-5	1	NSIN-1380-6	7	2000 (1180)	1000	750 (1650)
U_N = 690 V						
0800A-7	1	NSIN-0900-6	7	2000 (1180)	1000	550 (1210)
0800A-7+A004	1	NSIN-0900-6	7	2000 (1180)	1000	550 (1210)
0900A-7	1	NSIN-1380-6	7	2000 (1180)	1000	750 (1650)
0950A-7+A004	1	NSIN-1380-6	7	2000 (1180)	1000	750 (1650)
1160A-7	1	NSIN-1380-6	7	2000 (1180)	1000	750 (1650)
1160A-7+A004	1	NSIN-1380-6	7	2000 (1180)	1000	750 (1650)

Terminal and lead-through data for the power cables

The locations and sizes of lead-throughs are shown by the dimension drawings delivered with the drive, and the dimension drawing examples starting on page [211](#).

The location and size of power cable terminals are shown in the drawings starting on page [235](#).

Terminal data for the supply and inverter control units

See chapter [Control units of the drive](#) (page [127](#)).

Electrical power network specification

Voltage (U_1)	ACS880-07-xxxx-3: 380...415 V AC 3-phase $\pm 10\%$. This is indicated in the type designation label as typical input voltage level (3~ 400 V AC). ACS880-07-xxxx-5: 380...500 V AC 3-phase $\pm 10\%$. This is indicated in the type designation label as typical input voltage levels (3~ 400/480/500 V AC). ACS880-07-xxxx-7: *525...690 V AC 3-phase $\pm 10\%$. This is indicated in the type designation label as typical input voltage levels (3~ 525/600/690 V AC). *525...600 V AC in corner-grounded TN systems
Network type	TN (grounded) and IT (ungrounded) systems
Frequency	47 to 63 Hz, maximum rate of change 17%/s
Imbalance	Max. $\pm 3\%$ of nominal phase-to-phase input voltage
Short-circuit withstand strength (IEC 61439-1)	<u>ACS880-07-2610A-3, ACS880-07-2300A-7 and ACS880-07-2860A-7 without grounding/earthing switch (ie. without option +F259):</u> Rated peak withstand current (I_{pk}): 143 kA Rated short-time withstand current (I_{cw}): 65 kA/1 s <u>All other configurations:</u> Rated peak withstand current (I_{pk}): 105 kA Rated short-time withstand current (I_{cw}): 50 kA/1 s
Short-circuit current protection (UL 508A, CSA C22.2 No. 14-05)	The drive is suitable for use on a circuit capable of delivering not more than 100,000 rms symmetrical amperes at 600 V maximum when the input cable is protected with T class fuses.
Fundamental power factor ($\cos \phi_1$)	0.98 (at nominal load)
Transformer specification for 12-pulse supply (IEC 60076-1:2011)	<u>Connection:</u> Dy 11 d0 or Dyn 11 d0 <u>Phase shift between secondaries:</u> 30° electrical <u>Voltage difference between secondaries:</u> < 0.5% <u>Short-circuit impedance of secondaries:</u> > 5% <u>Short-circuit impedance difference between secondaries:</u> $\leq 10\%$ of the percentage impedance No grounding of the secondaries allowed. Static shield recommended.

Motor connection data

Motor types	Asynchronous AC induction motors, permanent magnet synchronous motors and AC induction servomotors
Voltage (U_2)	0 to U_1 , 3-phase symmetrical, U_{max} at the field weakening point
Frequency	0... ± 500 Hz (0... ± 120 Hz with sine output filters [option +E206]) <ul style="list-style-type: none"> For higher operational output frequencies, please contact your local ABB representative. Operation above 150 Hz may require type-specific derating. For more information, contact your local ABB representative.
Current	See section Ratings .
Switching frequency	2 kHz (typical)
Maximum recommended motor cable length	500 m (1640 ft). Note: With motor cables longer than 150 m (492 ft) the EMC Directive requirements may not be fulfilled.

Control unit connection data

See chapter [Control units of the drive](#) (page 127).

Efficiency

97.2 ... 98.0% at nominal power level depending on drive type

Protection classes

Degrees of protection (IEC/EN 60529)	IP22 (standard), IP42 (optional), IP54 (optional)
Enclosure types (UL50)	UL Type 1 (standard), UL Type 1 Filtered (option +B054), UL Type 12 (option +B055). For indoor use only.
Overvoltage category (IEC 60664-1)	III
Protective class (IEC/EN 61800-5-1)	I

Ambient conditions

Environmental limits for the drive are given below. The drive is to be used in a heated, indoor, controlled environment.

	Operation installed for stationary use	Storage in the protective package	Transportation in the protective package
Installation site altitude	0 to 4000 m (13123 ft) above sea level. Output derated above 1000 m (3281 ft). See section Derating .	-	-
Air temperature	0 ... +40 °C (+32 ... +104 °F). No condensation allowed. Output derated in the range +40 ... +50 °C (+104 ... +122 °F). See section Derating .	-40 to +70 °C (-40 to +158 °F)	-40 to +70 °C (-40 to +158 °F)
Relative humidity	Max. 95%	Max. 95%	Max. 95%
	No condensation allowed. Maximum allowed relative humidity is 60% in the presence of corrosive gases.		
Contamination	IEC/EN 60721-3-3:2002: Classification of environmental conditions - Part 3-3: Classification of groups of environmental parameters and their severities - Stationary use of weather protected locations	IEC 60721-3-1:1997	IEC 60721-3-2:1997
Chemical gases	Class 3C2	Class 1C2	Class 2C2
Solid particles	Class 3S2. No conductive dust allowed.	Class 1S3 (packing must support this, otherwise 1S2)	Class 2S2

Vibration IEC 61800-5-1 IEC 60068-2-6:2007, EN 60068-2-6:2008 Environmental testing Part 2: Tests –Test Fc: Vibration (sinusoidal)	IEC/EN 60721-3-3:2002 10...57 Hz: max. 0.075 mm amplitude 57...150 Hz: 1 g Units with marine construction (option +C121): Max. 1 mm (0.04 in.) (5 ... 13.2 Hz), max. 0.7 g (13.2 ... 100 Hz) sinusoidal	IEC/EN 60721-3-1:1997 10...57 Hz: max. 0.075 mm amplitude 57...150 Hz: 1 g	IEC/EN 60721-3-2:1997 2...9 Hz: max. 3.5 mm amplitude 9...200 Hz: 10 m/s ² (32.8 ft/s ²)
Shock IEC 60068-2-27:2008, EN 60068-2-27:2009 Environmental testing - Part 2-27: Tests - Test Ea and guidance: Shock	Not allowed	With packing max. 100 m/s ² (328 ft/s ²) 11 ms	With packing max. 100 m/s ² (328 ft/s ²) 11 ms

Materials

Cabinet	Hot-dip zinc coated 1.5 mm thick steel sheet (thickness of coating approximately 20 micrometers). Polyester thermosetting powder coating (thickness approximately 80 micrometers) on visible surfaces, color RAL 7035 and RAL 9017. PC/ABS 3 mm, color NCS 1502-Y (RAL 9002 / PMS 1C Cool Grey).
Busbars	Tin-plated copper
Fire safety of materials (IEC 60332-1)	Insulating materials and non-metallic items mostly self-extinctive
Package	Standard package: <ul style="list-style-type: none"> • timber, polyethylene sheet (thickness 0.2 mm), stretch film (thickness 0.023 mm), PP tape, PET strap, sheet metal (steel) • for land and air transport when planned storage time is less than 2 months or when storage can be arranged in clean and dry conditions less than 6 months • can be used when products will not be exposed to corrosive atmosphere during transport or storage Container package: <ul style="list-style-type: none"> • timber, VCI sheet film (PE, thickness 0.15 mm), VCI stretch film (PE, thickness 0.04 mm), VCI emitter bags, PP tape, PET strap, sheet metal (steel) • for sea transport in containers • recommended for land and air transport when storage time prior to installation exceeds 6 months or storage is arranged in partially weather-protected conditions Seaworthy package: <ul style="list-style-type: none"> • timber, plywood, VCI sheet film (PE, thickness 0.15 mm), VCI stretch film (PE, thickness 0.04 mm), VCI emitter bags, PP tape, PET strap, sheet metal (steel) • for sea transport with or without containerization • for long storage periods in environments where roofed and humidity-controlled storage cannot be arranged Cabinets are fastened to the pallet with screws and braced from the top end to the package walls to prevent swaying inside the package. Package elements are attached together with screws. For handling the packages, see section Moving and unpacking the drive on page 59.

Disposal

The main parts of the drive can be recycled to preserve natural resources and energy. Product parts and materials should be dismantled and separated.

Generally all metals, such as steel, aluminum, copper and its alloys, and precious metals can be recycled as material. Plastics, rubber, cardboard and other packaging material can be used in energy recovery. Printed circuit boards and DC capacitors (C1-1 to C1-x) need selective treatment according to IEC 62635 guidelines. To aid recycling, plastic parts are marked with an appropriate identification code.

Contact your local ABB distributor for further information on environmental aspects and recycling instructions for professional recyclers. End of life treatment must follow international and local regulations.

Applicable standards

The drive complies with the standards below. The compliance with the European Low Voltage Directive is verified according to standard EN 61800-5-1.

EN 61800-5-1:2007	<i>Adjustable speed electrical power drive systems. Part 5-1: Safety requirements – electrical, thermal and energy</i>
EN 60204-1:2006 +A1 2009	<i>Safety of machinery. Electrical equipment of machines. Part 1: General requirements. Provisions for compliance: The final assembler of the machine is responsible for installing emergency-stop device.</i>
IEC/EN 60529:1991 + A1 2000	<i>Degrees of protection provided by enclosures (IP code)</i>
EN 61800-3:2004	<i>Adjustable speed electrical power drive systems. Part 3: EMC requirements and specific test methods</i>
UL 501:2007	<i>Enclosures for Electrical Equipment, Non-Environmental Considerations</i>
UL 508C:2002	<i>UL Standard for Safety, Power Conversion Equipment, third edition</i>
UL 508A:2001	<i>UL Standard for Industrial Control Panels, first edition</i>
CSA C22.2 No. 14-10	<i>Industrial control equipment</i>

CE marking

A CE mark is attached to the drive to verify that the drive complies with the provisions of the European Low Voltage and EMC Directives. The CE marking also verifies that the drive, in regard to its safety functions (such as Safe torque off), conforms with the Machinery Directive as a safety component.

■ Compliance with the European Low Voltage Directive

The compliance with the European Low Voltage Directive has been verified according to standard EN 61800-5-1.

■ Compliance with the European EMC Directive

The EMC Directive defines the requirements for immunity and emissions of electrical equipment used within the European Union. The EMC product standard (EN 61800-3:2004) covers requirements stated for drives. See section [Compliance with EN 61800-3:2004](#) below.

■ Compliance with the European Machinery Directive

The drive is an electronic product which is covered by the European Low Voltage Directive. However, the drive includes the Safe torque off function and can be equipped with other safety functions for machinery which, as safety components, are in the scope of the Machinery Directive. These functions of the drive comply with European harmonized standards such as EN 61800-5-2. The related declarations of conformity are shown below.

Declaration of Conformity

See also chapter *The Safe torque off function* (page 249), and section *Implementing the functions provided by the FSO-xx safety functions module (option +Q972 or +Q973)* (page 89).



Declaration of Conformity

(According to Machinery Directive 2006/42/EC)

Manufacturer: ABB Oy, Drives
Address: Hiomotie 13, P.O Box 184, 00381 Helsinki, Finland.

hereby declares that products

ACS880-04, -14, -34	380V – 690V (frames nxR8i)
ACS880-04XT	380V – 690V (frames 2xR10 and 2xR11)
ACS880-07	380V – 690V (frames R6 – R11 and nxR8i)
ACS880-17, -37	380V – 690V (frames nxR8i)
ACS880-104	380V – 690V (frames R1i – nxR8i)
ACS880 multidrives	380V – 690V (inverter frames R1i – nxR8i)

with regard to the safety functions

Safe torque off

Safe stop 1, Safe stop emergency, Safely-limited speed, Safe maximum speed, Safe brake control, Prevention of unexpected start-up, with FSO-12 module (option code +Q973)

ACS880-07, -17, -37 and ACS880 multidrives: Prevention of unexpected start-up (option codes +Q950; +Q957), **Emergency stop** (option codes +Q951; +Q952; +Q963; +Q964; +Q978; +Q979), **Safely-limited speed** (option code +Q966)

fulfil all the relevant safety component requirements of EC Machinery Directive 2006/42/EC, when the listed safety functions are used for safety component functionality.

The following harmonized standards below were used:

EN 61800-5-2: 2007	<i>Adjustable speed electrical power drive systems – Part 5-2: Safety requirements - Functional</i>
EN 62061: 2005 + A1: 2013	<i>Safety of machinery – Functional safety of safety-related electrical, electronic and programmable electronic control systems</i>
EN ISO 13849-1: 2008 + AC: 2009	<i>Safety of machinery – Safety-related parts of control systems. Part 1: General requirements</i>
EN ISO 13849-2: 2012	<i>Safety of machinery – Safety-related parts of the control systems. Part 2: Validation</i>
EN 60204-1: 2006 + AC: 2010	<i>Safety of machinery – Electrical equipment of machines – Part 1: General requirements</i>

Other used standards:

IEC 61508 ed. 2: 2010	Functional safety of electrical / electronic / programmable electronic safety-related systems
-----------------------	---



Declaration of Conformity

(According to Machinery Directive 2006/42/EC)

The products referred in this Declaration of Conformity fulfil the relevant provisions of the Low Voltage Directive 2006/95/EC and EMC Directive 2004/108/EC. Declaration of conformity according to these directives is available from the manufacturer.

Person authorized to compile the technical file:

Name: Vesa Tiihonen
Address: P.O. Box 184, 00381 Helsinki, Finland

Helsinki, 1 Jul 2015

A handwritten signature in blue ink, appearing to read 'Peter Lindgren', is written over a horizontal line.

Peter Lindgren
Vice President
ABB Oy

Compliance with EN 61800-3:2004

■ Definitions

EMC stands for **E**lectromagnetic **C**ompatibility. It is the ability of electrical/electronic equipment to operate without problems within an electromagnetic environment. Likewise, the equipment must not disturb or interfere with any other product or system within its locality.

First environment includes establishments connected to a low-voltage network which supplies buildings used for domestic purposes.

Second environment includes establishments connected to a network not supplying domestic premises.

Drive of category C2: drive of rated voltage less than 1000 V and intended to be installed and started up only by a professional when used in the first environment. **Note:** A professional is a person or organization having necessary skills in installing and/or starting up power drive systems, including their EMC aspects.

Drive of category C3: drive of rated voltage less than 1000 V and intended for use in the second environment and not intended for use in the first environment.

Drive of category C4: drive of rated voltage equal to or above 1000 V, or rated current equal to or above 400 A, or intended for use in complex systems in the second environment.

■ Category C2

The drive complies with the standard with the following provisions:

1. The drive is equipped with EMC filter (option +E202).
2. The motor and control cables are selected as specified in the hardware manual.
3. The drive is installed according to the instructions given in the hardware manual.
4. Maximum motor cable length is 100 meters (328 ft).

WARNING! The drive may cause radio interference if used in a residential or domestic environment. The user is required to take measures to prevent interference, in addition to the requirements for CE compliance listed above, if necessary.

Note: Do not install a drive equipped with EMC filter +E202 on IT (ungrounded) systems. The supply network becomes connected to ground potential through the EMC filter capacitors which may cause danger or damage the unit.

■ Category C3

The drive complies with the standard with the following provisions:

1. The motor and control cables are selected as specified in the hardware manual.
2. The drive is installed according to the instructions given in the hardware manual.
3. Maximum motor cable length is 100 meters (328 ft).

WARNING! A drive of category C3 is not intended to be used on a low-voltage public network which supplies domestic premises. Radio frequency interference is expected if the drive is used on such a network.

■ Category C4

If the provisions under *Category C3* cannot be met, the requirements of the standard can be met as follows:

1. It is ensured that no excessive emission is propagated to neighbouring low-voltage networks. In some cases, the natural suppression in transformers and cables is sufficient. If in doubt, the supply transformer with static screening between the primary and secondary windings can be used.

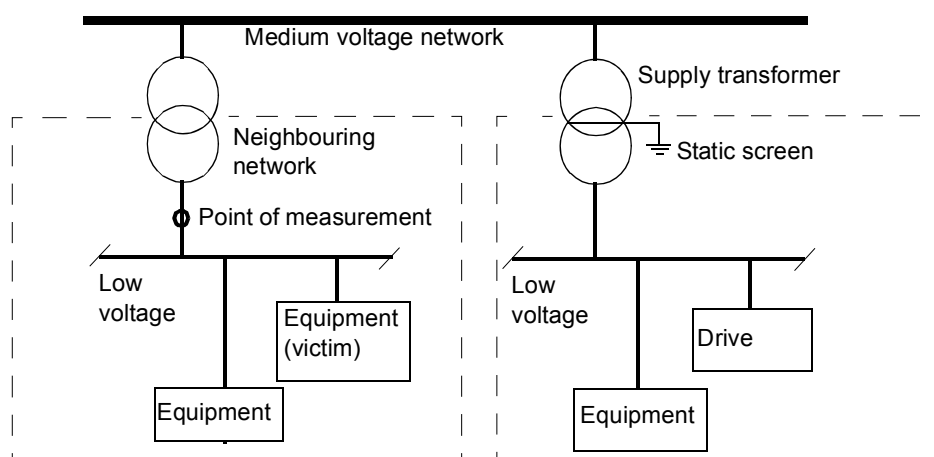

2. An EMC plan for preventing disturbances is drawn up for the installation. A template is available from the local ABB representative.
3. The motor and control cables are selected as specified in the hardware manual.
4. The drive is installed according to the instructions given in the hardware manual.

WARNING! A drive of category C4 is not intended to be used on a low-voltage public network which supplies domestic premises. Radio frequency interference is expected if the drive is used on such a network.

UL marking

■ UL checklist

- The drive is to be used in a heated, indoor controlled environment. The drive must be installed in clean air according to enclosure classification. Cooling air must be clean, free from corrosive materials and electrically conductive dust. See page [190](#).
- The maximum ambient air temperature is 40 °C (104 °F) at rated current. The current is derated for 40 to 50 °C (104 to 122 °F).
- The drive is suitable for use in a circuit capable of delivering not more than 100,000 rms symmetrical amperes, 600 V maximum when the input cable is protected with class T fuses given. The ampere rating is based on tests done according to UL 508A.
- The cables located within the motor circuit must be rated for at least 75 °C in UL-compliant installations.
- The input cable must be protected with fuses. Circuit breakers must not be used without fuses in the USA. For suitable circuit breakers, contact your local ABB representative. Suitable IEC (class aR) fuses and UL fuses for drive protection are listed starting on page [182](#).
- For installation in the United States, branch circuit protection must be provided in accordance with the National Electrical Code (NEC) and any applicable local codes. To fulfill this requirement, use the UL classified fuses.
- For installation in Canada, branch circuit protection must be provided in accordance with the Canadian Electrical Code and any applicable provincial codes. To fulfill this requirement, use the UL classified fuses.
- The drive provides overload protection in accordance with the National Electrical Code (NEC).

CSA marking

CSA marking is pending for the drive. The approval is valid with rated voltages.

“C-tick” marking

“C-tick” marking is required in Australia and New Zealand. A “C-tick” mark is attached to each drive in order to verify compliance with the relevant standard (IEC 61800-3:2004, *Adjustable speed electrical power drive systems – Part 3: EMC product standard including specific test methods*), mandated by the Trans-Tasman Electromagnetic Compatibility Scheme.

For fulfilling the requirements of the standard, see section [Compliance with EN 61800-3:2004](#).

EAC (Eurasian Conformity) marking

The drive has EAC certification. EAC marking is required in Russia, Belarus and Kazakhstan.

Tightening torques

Unless a tightening torque is specified in the text, the following torques can be used.

■ Electrical connections

Size	Torque N·m	Note
M3	0.5	Strength class 4.6...8.8
M4	1	Strength class 4.6...8.8
M5	4	Strength class 8.8
M6	9	Strength class 8.8
M8	22	Strength class 8.8
M10	42	Strength class 8.8
M12	70	Strength class 8.8
M16	120	Strength class 8.8

■ Mechanical connections

Size	Max. torque N·m	Note
M5	6	Strength class 8.8
M6	10	Strength class 8.8
M8	24	Strength class 8.8

■ Insulation supports

Size	Max. torque N·m	Note
M6	5	Strength class 8.8
M8	9	Strength class 8.8
M10	18	Strength class 8.8
M12	31	Strength class 8.8

■ Cable lugs

Size	Max. torque N·m	Note
M8	15	Strength class 8.8
M10	32	Strength class 8.8
M12	50	Strength class 8.8

Disclaimers

■ Generic disclaimer

The manufacturer shall have no obligation with respect to any product which (i) has been improperly repaired or altered; (ii) has been subjected to misuse, negligence or accident; (iii) has been used in a manner contrary to the manufacturer's instructions; or (iv) has failed as a result of ordinary wear and tear.

■ Cyber security disclaimer

This product is designed to be connected to and to communicate information and data via a network interface. It is Customer's sole responsibility to provide and continuously ensure a secure connection between the product and Customer network or any other network (as the case may be). Customer shall establish and maintain any appropriate measures (such as but not limited to the installation of firewalls, application of authentication measures, encryption of data, installation of anti-virus programs, etc) to protect the product, the network, its system and the interface against any kind of security breaches, unauthorized access, interference, intrusion, leakage and/or theft of data or information. ABB and its affiliates are not liable for damages and/or losses related to such security breaches, any unauthorized access, interference, intrusion, leakage and/or theft of data or information.

13

Dimensions

What this chapter contains

This chapter contains the following dimension data:

- Composition of cabinet line-ups in tabular form for each frame size with options (page [203](#))
 - Approximate weights of basic line-ups (page [210](#))
 - Dimension drawing examples of selected line-ups (page [211](#))
 - Location and size of input terminals (page [235](#))
 - Location and size of output terminals for drives without a common motor terminal cubicle (page [241](#)). This section also contains drawings of the terminals in sine filter and brake chopper cubicles.
 - Location and size of output terminals for drives with a common motor terminal cubicle (page [245](#)).
-

Cabinet line-up dimensions

The drive consists of cubicles built into a cabinet line-up. The tables below show the composition of cabinet line-ups for each frame size and the standard combinations of options. The dimensions are in millimeters.

Notes:

- The side panels at the left and right ends of the line-up increase the total line-up width by 30 millimeters (1.2”).
- The standard depth of the cabinet line-up is 644 mm (25.35”) excluding equipment such as handles and air inlet gratings. This is increased by 200 mm (7.87”) with top cable exit units, or by 130 mm with option +C128 (cooling air intake through bottom of cabinet).
- UL Listed (+C129) units are top cable entry/exit by default.
- The data given is preliminary. ABB reserves the right to modify the design at any time without notice. Consult ABB for up-to-date, drive-specific information.

The tables are followed by selected dimension drawing examples.

■ Dimension tables

1×D8T + 2×R8i – 6-pulse connection															
Auxiliary control cubicle (ACU)	Incoming cubicle (ICU)	EMC/RFI filter cubicle	Supply module cubicle	Inverter module cubicle	Common motor terminal cubicle	Sine filter cubicle	Joining cubicle	*Brake chopper 1	*Brake resistor 1	*Brake chopper 2	*Brake resistor 2	*Brake chopper 3	*Brake resistor 3	Shipping split widths	Line-up width
400	400		400	600										1800	1800
400	400	300	400	600										2100	2100
400	400		400	600	300									2100	2100
400	400	300	400	600	300									2400	2400
400	400		400	600		1000								2800	2800
400	400	300	400	600		1000								3100	3100
400	400		400	600				400		400				2600	2600
400	400	300	400	600				400		400				2900	2900
400	400		400	600	300			400		400				2900	2900
400	400	300	400	600	300			400		400				3200	3200
400	400		400	600		1000		400		400				3600	3600
400	400	300	400	600		1000		400		400				3900	3900
400	400		400	600				400	800	400	800			4200	4200
400	400	300	400	600			200	400	800	400	800			2300 + 2400	4700
400	400		400	600	300			400	800	400	800			2100 + 2400	4500
400	400	300	400	600	300			400	800	400	800			2400 + 2400	4800
400	400		400	600		1000	200	400	800	400	800			3000 + 2400	5400
400	400	300	400	600		1000	200	400	800	400	800			3300 + 2400	5700
400	400		400	600				400		400		400		3000	3000
400	400	300	400	600				400		400		400		3300	3300
400	400		400	600	300			400		400		400		3300	3300
400	400	300	400	600	300			400		400		400		3600	3600
400	400		400	600		1000		400		400		400		4000	4000
400	400	300	400	600		1000	200	400		400		400		3300 + 1200	4500
400	400		400	600			200	400	800	400	800	400	800	2000 + 3600	5600
400	400	300	400	600			200	400	800	400	800	400	800	2300 + 3600	5900
400	400		400	600	300			400	800	400	800	400	800	2100 + 3600	5700
400	400	300	400	600	300			400	800	400	800	400	800	2400 + 3600	6000
400	400		400	600		1000	200	400	800	400	800	400	800	3000 + 3600	6600
400	400	300	400	600		1000	200	400	800	400	800	400	800	3300 + 3600	6900

*The number of brake choppers depends on required braking power. See chapter [Resistor braking](#).

2xD7T + 2xR8i – 12-pulse connection without option +F259 (grounding switch)															
Auxiliary control cubicle (ACU)	Incoming cubicle (ICU)	Adapter for top cable entry	Supply module cubicle	Inverter module cubicle	Common motor terminal cubicle	Sine filter cubicle	Joining cubicle	*Brake chopper 1	*Brake resistor 1	*Brake chopper 2	*Brake resistor 2	*Brake chopper 3	*Brake resistor 3	Shipping split widths	Line-up width
400	600		400	600										2000	2000
400	600	200	400	600										2200	2200
400	600		400	600	300									2300	2300
400	600	200	400	600	300									2500	2500
400	600		400	600		1000								3000	3000
400	600	200	400	600		1000								3200	3200
400	600		400	600				400		400				2800	2800
400	600	200	400	600				400		400				3000	3000
400	600		400	600	300			400		400				3100	3100
400	600	200	400	600	300			400		400				3300	3300
400	600		400	600		1000		400		400				3800	3800
400	600	200	400	600		1000		400		400				4000	4000
400	600		400	600			200	400	800	400	800			2200 + 2400	4600
400	600	200	400	600			200	400	800	400	800			2400 + 2400	4800
400	600		400	600	300			400	800	400	800			2300 + 2400	4700
400	600	200	400	600	300			400	800	400	800			2500 + 2400	4900
400	600		400	600		1000	200	400	800	400	800			3200 + 2400	5600
400	600	200	400	600		1000	200	400	800	400	800			3400 + 2400	5800
400	600		400	600				400		400		400		3200	3200
400	600	200	400	600				400		400		400		3400	3400
400	600		400	600	300			400		400		400		3500	3500
400	600	200	400	600	300			400		400		400		3700	3700
400	600		400	600		1000		400		400		400		4200	4200
400	600	200	400	600		1000	200	400		400		400		3400 + 1200	4600
400	600		400	600			200	400	800	400	800	400	800	2200 + 3600	5800
400	600	200	400	600			200	400	800	400	800	400	800	2400 + 3600	6000
400	600		400	600	300			400	800	400	800	400	800	2300 + 3600	5900
400	600	200	400	600	300			400	800	400	800	400	800	2500 + 3600	6100
400	600		400	600		1000	200	400	800	400	800	400	800	3200 + 3600	6800
400	600	200	400	600		1000	200	400	800	400	800	400	800	3400 + 3600	7000

*The number of brake choppers depends on required braking power. See chapter [Resistor braking](#).

2×D7T + 2×R8i – 12-pulse connection with option +F259 (grounding switch)															
Auxiliary control cubicle (ACU)	Incoming cubicle (ICU) 1	Supply module cubicle	Incoming cubicle (ICU) 2	Inverter module cubicle	Common motor terminal cubicle	Sine filter cubicle	Joining cubicle	*Brake chopper 1	*Brake resistor 1	*Brake chopper 2	*Brake resistor 2	*Brake chopper 3	*Brake resistor 3	Shipping split widths	Line-up width
400	400	400	400	600										2200	2200
400	400	400	400	600	300									2500	2500
400	400	400	400	600		1000								3200	3200
400	400	400	400	600				400		400				3000	3000
400	400	400	400	600	300			400		400				3300	3300
400	400	400	400	600		1000		400		400				4000	4000
400	400	400	400	600			200	400	800	400	800			2400 + 2400	4800
400	400	400	400	600	300			400	800	400	800			2500 + 2400	4900
400	400	400	400	600		1000	200	400	800	400	800			3400 + 2400	5800
400	400	400	400	600				400		400		400		3400	3400
400	400	400	400	600	300			400		400		400		3700	3700
400	400	400	400	600		1000	200	400		400		400		3400 + 1200	4600
400	400	400	400	600			200	400	800	400	800	400	800	2400 + 3600	6000
400	400	400	400	600	300			400	800	400	800	400	800	2500 + 3600	6100
400	400	400	400	600		1000	200	400	800	400	800	400	800	3400 + 3600	7000

*The number of brake choppers depends on required braking power. See chapter [Resistor braking](#).

2×D8T + 2×R8i – 6-pulse connection, 400/500 V																
Auxiliary control cubicle (ACU)	Incoming cubicle (ICU)	Adapter for top cable entry	Supply module cubicle	Inverter module cubicle	Joining cubicle	Common motor terminal cubicle	Sine filter cubicle	Joining cubicle	*Brake chopper 1	*Brake resistor 1	*Brake chopper 2	*Brake resistor 2	*Brake chopper 3	*Brake resistor 3	Shipping split widths	Line-up width
400	600		600	600											2200	2200
400	600	200	600	600											2400	2400
400	600		600	600		300									2500	2500
400	600	200	600	600		300									2700	2700
400	600		600	600			1000								3200	3200
400	600	200	600	600			1000								3400	3400
400	600		600	600				400		400		400			3400	3400
400	600	200	600	600				400		400		400			3600	3600
400	600		600	600	200			400	800	400	800	400	800		2400 + 3600	6000
400	600	200	600	600	200			400	800	400	800	400	800		2600 + 3600	6200
400	600		600	600		300		400		400		400			3700	3700
400	600	200	600	600		300		400		400		400			3900	3900
400	600		600	600		300		400	800	400	800	400	800		2500 + 3600	6100
400	600	200	600	600		300		400	800	400	800	400	800		2700 + 3600	6300
400	600		600	600	200		1000	400		400		400			2400 + 2200	4600
400	600	200	600	600	200		1000	400		400		400			2600 + 2200	4800
400	600		600	600			1000	200	400	800	400	800	400	800	3400 + 3600	7000
400	600	200	600	600			1000	200	400	800	400	800	400	800	3600 + 3600	7200

*The number of brake choppers depends on required braking power. See chapter [Resistor braking](#).

2×D8T + 2×R8i – 6-pulse connection, 690 V															
Auxiliary control cubicle (ACU)	Incoming cubicle (ICU)	Supply module cubicle	Inverter module cubicle	Joining cubicle	Common motor terminal cubicle	Sine filter cubicle	Joining cubicle	*Brake chopper 1	*Brake resistor 1	*Brake chopper 2	*Brake resistor 2	*Brake chopper 3	*Brake resistor 3	Shipping split widths	Line-up width
400	400	600	600											2000	2000
400	400	600	600		300									2300	2300
400	400	600	600			1000								3000	3000
400	400	600	600					400		400		400		3200	3200
400	400	600	600	200				400	800	400	800	400	800	2200 + 3600	5800
400	400	600	600		300			400		400		400		3500	3500
400	400	600	600		300			400	800	400	800	400	800	2300 + 3600	5900
400	400	600	600			1000		400		400		400		4200	4200
400	400	600	600			1000	200	400	800	400	800	400	800	3200 + 3600	6800

*The number of brake choppers depends on required braking power. See chapter [Resistor braking](#).

2×D8T + 2×R8i – 12-pulse connection without option +F259 (grounding switch)														
Auxiliary control cubicle (ACU)	Incoming cubicle (ICU)	Adapter for top cable entry	Supply module cubicle	Inverter module cubicle	Common motor terminal cubicle	Joining cubicle	*Brake chopper 1	*Brake resistor 1	*Brake chopper 2	*Brake resistor 2	*Brake chopper 3	*Brake resistor 3	Shipping split widths	Line-up width
400	600		600	600									2200	2200
400	600	200	600	600									2400	2400
400	600		600	600	300								2500	2500
400	600	200	600	600	300								2800	2800
400	600		600	600			400		400		400		3400	3400
400	600	200	600	600			400		400		400		3600	3600
400	600		600	600		200	400	800	400	800	400	800	2400 + 3600	6000
400	600	200	600	600		200	400	800	400	800	400	800	2600 + 3600	6200
400	600		600	600	300		400		400		400		3700	3700
400	600	200	600	600	300		400		400		400		3900	3900
400	600		600	600	300		400	800	400	800	400	800	2500 + 3600	6100
400	600	200	600	600	300		400	800	400	800	400	800	2700 + 3600	6300

*The number of brake choppers depends on required braking power. See chapter [Resistor braking](#).

2×D8T + 2×R8i – 12-pulse connection with option +F259 (grounding switch)														
Auxiliary control cubicle (ACU)	Incoming cubicle (ICU) 1	Supply module cubicle	Incoming cubicle (ICU) 2	Inverter module cubicle	Common motor terminal cubicle	Joining cubicle	*Brake chopper 1	*Brake resistor 1	*Brake chopper 2	*Brake resistor 2	*Brake chopper 3	*Brake resistor 3	Shipping split widths	Line-up width
400	400	600	400	600									2400	2400
400	400	600	400	600	300								2700	2700
400	400	600	400	600			400		400		400		3600	3600
400	400	600	400	600		200	400	800	400	800	400	800	2600 + 3600	6200
400	400	600	400	600	300		400		400		400		3900	3900
400	400	600	400	600	300		400	800	400	800	400	800	2700 + 3600	6300

*The number of brake choppers depends on required braking power. See chapter [Resistor braking](#).

2×D8T + 3×R8i – 6-pulse connection; 12-pulse connection without option +F259 (grounding switch)							
Supply voltage range (V)	Auxiliary control cubicle (ACU)	Incoming cubicle (ICU)	Adapter for top cable entry	Supply module cubicle	Inverter module cubicle	Common motor terminal cubicle	Line-up width
500/690	400	600		600	800		2400
500/690	400	600	200	600	800		2600
500	400	600		600	800	400	2800
690	400	600		600	800	300	2700
500	400	600	200	600	800	400	3000
690	400	600	200	600	800	300	2900

2×D8T + 3×R8i – 12-pulse connection with option +F259 (grounding switch)							
Supply voltage range (V)	Auxiliary control cubicle (ACU)	Incoming cubicle (ICU) 1	Supply module cubicle	Incoming cubicle (ICU) 2	Inverter module cubicle	Common motor terminal cubicle	Line-up width
500/690	400	400	600	400	800		2400
500	400	400	600	400	800	400	3000
690	400	400	600	400	800	300	2900

3×D8T + 3×R8i						
Auxiliary control cubicle (ACU)	Incoming cubicle (ICU)	Adapter for top cable entry	Supply module cubicle	Inverter module cubicle	*Common motor terminal cubicle	Line-up width
400	600		800	800		2600
400	600	200	800	800		2800
400	600		800	800	400	3000
400	600	200	800	800	400	3200
400	600	200	800	800	600	3400

*600 mm with ACS880-07-2610-3 with top cable exit, otherwise 400 mm.

3×D8T + 4×R8i							
Auxiliary control cubicle (ACU)	Incoming cubicle (ICU)	Adapter for top cable entry	Supply module cubicle	Inverter module cubicle 1	Common motor terminal cubicle	Inverter module cubicle 2	Line-up width
400	600		800	600		600	3000
400	600	200	800	600		600	3200
400	600		800	600	400	600	3400
400	600	200	800	600	600	600	3800

208 Dimensions

4×D8T + 3×R8i											
Auxiliary control cubicle (ACU)	Incoming cubicle (ICU) 1	Adapter for top cable entry 1	Supply module cubicle 1	Supply module cubicle 2	*Adapter for top cable entry 2	*Incoming cubicle (ICU) 2	Joining cubicle	Inverter module cubicle	**Common motor terminal cubicle	Shipping split widths	Line-up width
400	600		600	600				800		3000	3000
400	600	200	600	600				800		3200	3200
400	600		600	600				800	400	3400	3400
400	600	200	600	600				800	600	3800	3800
400	600		600	600		600		800		3600	3600
400	600	200	600	600	200	600		800		4000	4000
400	600		600	600		600		800	400	4000	4000
400	600	200	600	600	200	600	200	800	600	3400 + 1400	4800

*Units with option +F259 (grounding switch) only.

**600 mm with ACS880-07-2610-3+A004 with top cable exit, otherwise 400 mm.

4×D8T + 4×R8i													
Auxiliary control cubicle (ACU)	Incoming cubicle (ICU) 1	Adapter for top cable entry 1	Supply module cubicle 1	Supply module cubicle 2	*Adapter for top cable entry 2	*Incoming cubicle (ICU) 2	Joining cubicle	Inverter module cubicle 1	**Common motor terminal cubicle	Inverter module cubicle 2	**Common motor terminal cubicle	Shipping split widths	Line-up width
400	600		600	600				600		600		3400	3400
400	600	200	600	600				600		600		3600	3600
400	600		600	600				600	400	600		3800	3800
400	600	200	600	600				600	400	600		4200	4200
400	600	200	600	600				600	600	600		4000	4000
400	600		600	600		600		600		600		4000	4000
400	600	200	600	600	200	600	200	600		600		3400 + 1200	4600
400	600		600	600		600		600	400	600		3800 + 600	4400
400	600	200	600	600	200	600	200	600	600	600		3400 + 1800	5200

*Units with option +F259 (grounding switch) only.

**600 mm with ACS880-07-2300A-7+A004 with top cable exit, otherwise 400 mm.

4×D8T + 5×R8i												
Auxiliary control cubicle (ACU)	*Incoming cubicle (ICU) 1	Adapter for top cable entry 1	Supply module cubicle 1	Supply module cubicle 2	** Adapter for top cable entry 2	** Incoming cubicle (ICU) 2	Joining cubicle	Inverter module cubicle 1	Common motor terminal cubicle	Inverter module cubicle 1	Shipping split widths	Line-up width
400	600		600	600				800		600	3600	3600
400	600	200	600	600				800		600	3800	3800
400	600		600	600				800	600	600	4200	4200
400	600	200	600	600				800	600	600	3800 + 600	4400
400	1000		600	600				800		600	4000	4000
400	1000	200	600	600				800		600	4200	4200
400	1000		600	600				800	600	600	4000 + 600	4600
400	1000	200	600	600				800	600	600	4200 + 600	4800
400	600		600	600		600		800		600	4200	4200
400	600	200	600	600	200	600	200	800		600	3400 + 1400	4800
400	600		600	600		600		800	400	600	4000 + 600	4600
400	600	200	600	600	200	600	200	800	600	600	3400 + 2000	5400

*1000 mm with 6-pulse UL Listed (+C129) and CSA Approved (+C134) units, otherwise 600 mm.

**12-pulse units with option +F259 (grounding switch) only.

■ Weights

The table below lists the approximate basic weights of the ACS880-07 frame sizes.

Frame size	Weight	
	kg	lbs
1×D8T + 2×R8i	1470	3240
2×D7T + 2×R8i	1710	3770
2×D8T + 2×R8i (6-pulse)	1770	3900
2×D8T + 2×R8i (12-pulse)	1870	4120
2×D8T + 3×R8i (6-pulse)	1920	4230
2×D8T + 3×R8i (12-pulse)	2020	4450
3×D8T + 3×R8i	2230	4920
3×D8T + 4×R8i	2590	5710
4×D8T + 3×R8i	2600	5730
4×D8T + 4×R8i	2960	6530
4×D8T + 5×R8i	3110	6860

■ Dimension drawing examples

Frame 2×D7T + 2×R8i (12-pulse)

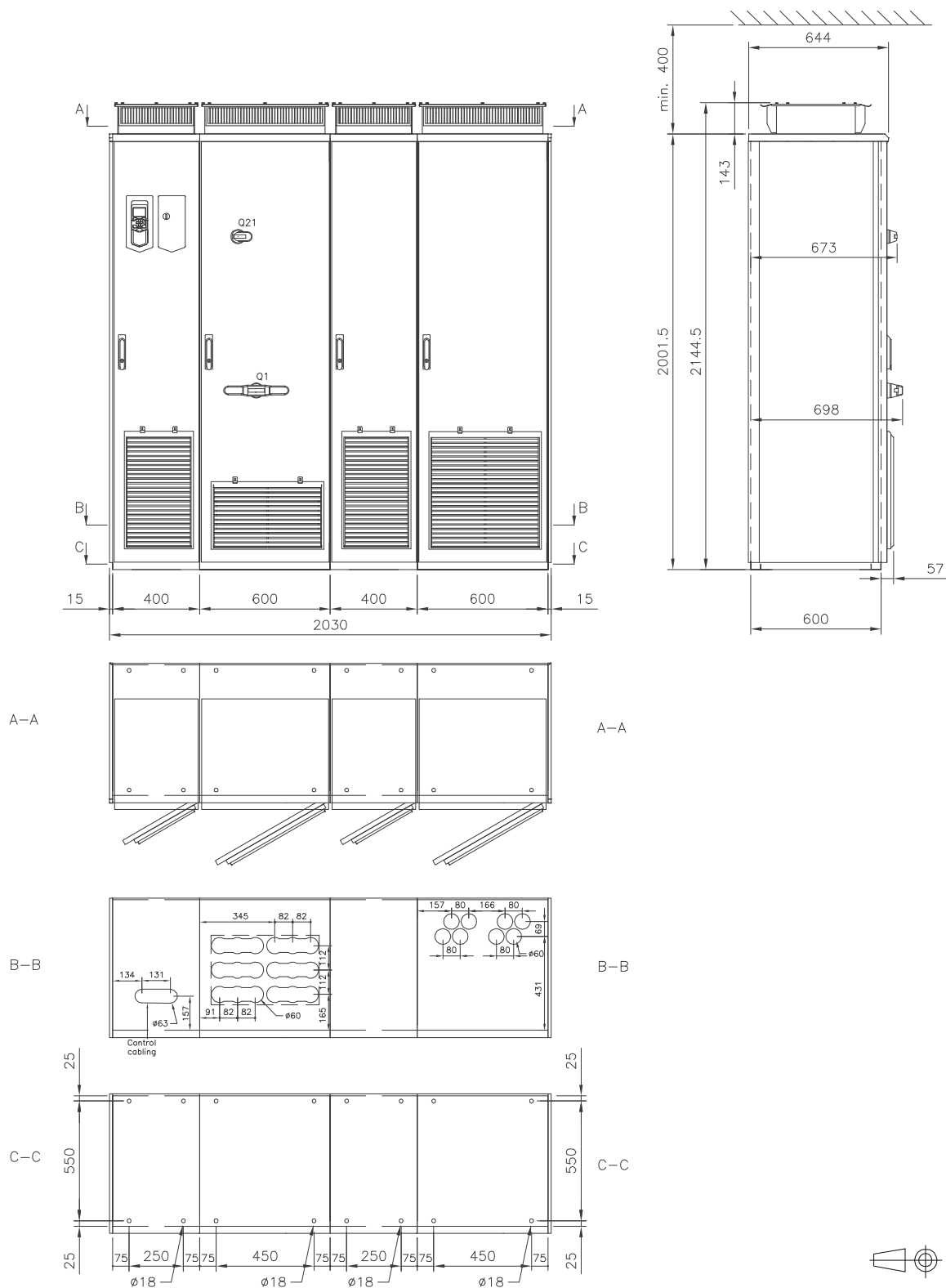

Frame 1xD8T + 2xR8i (IP22)

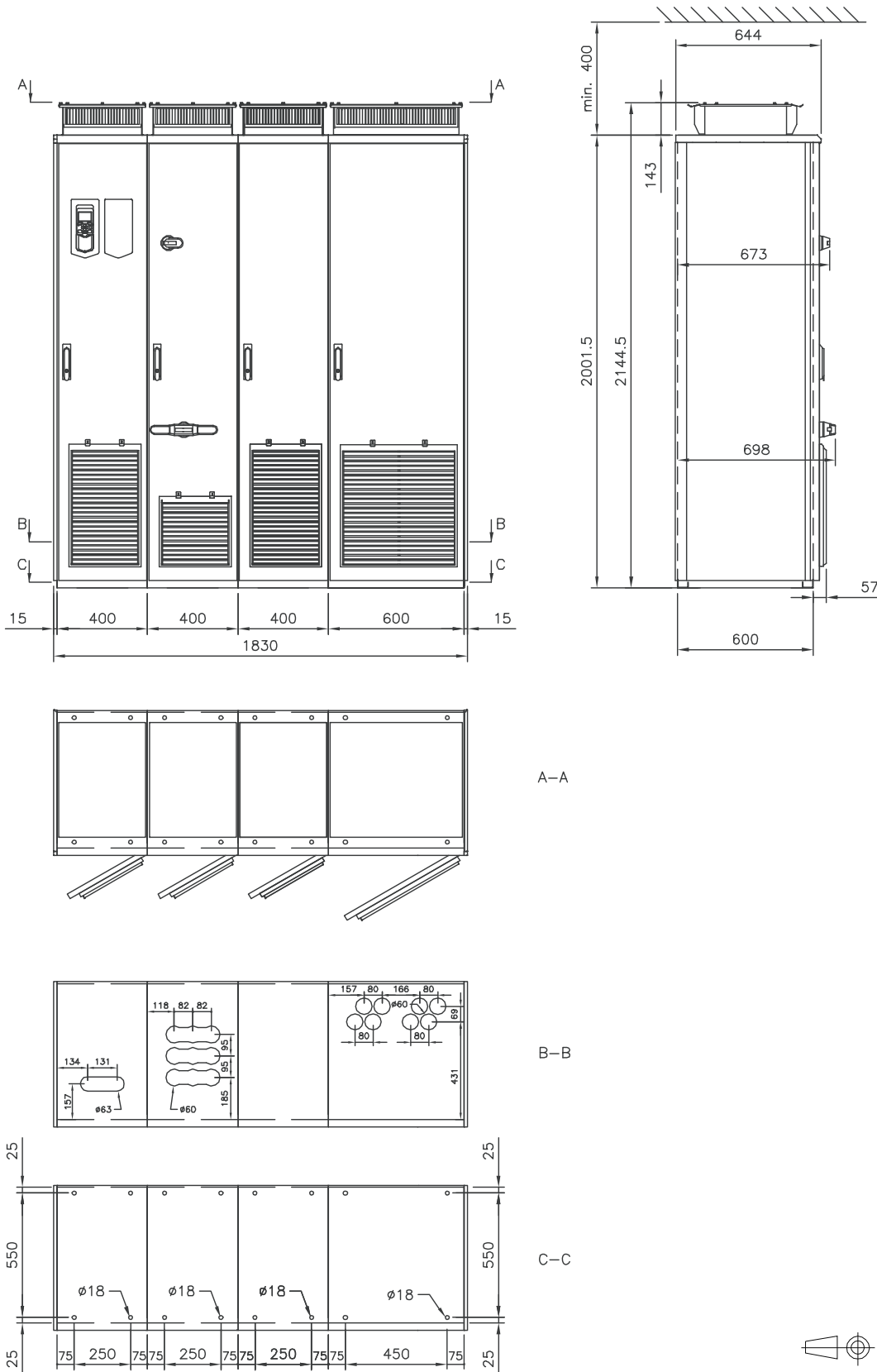

Frame 1xD8T + 2xR8i, IP54 (+B055)

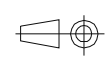
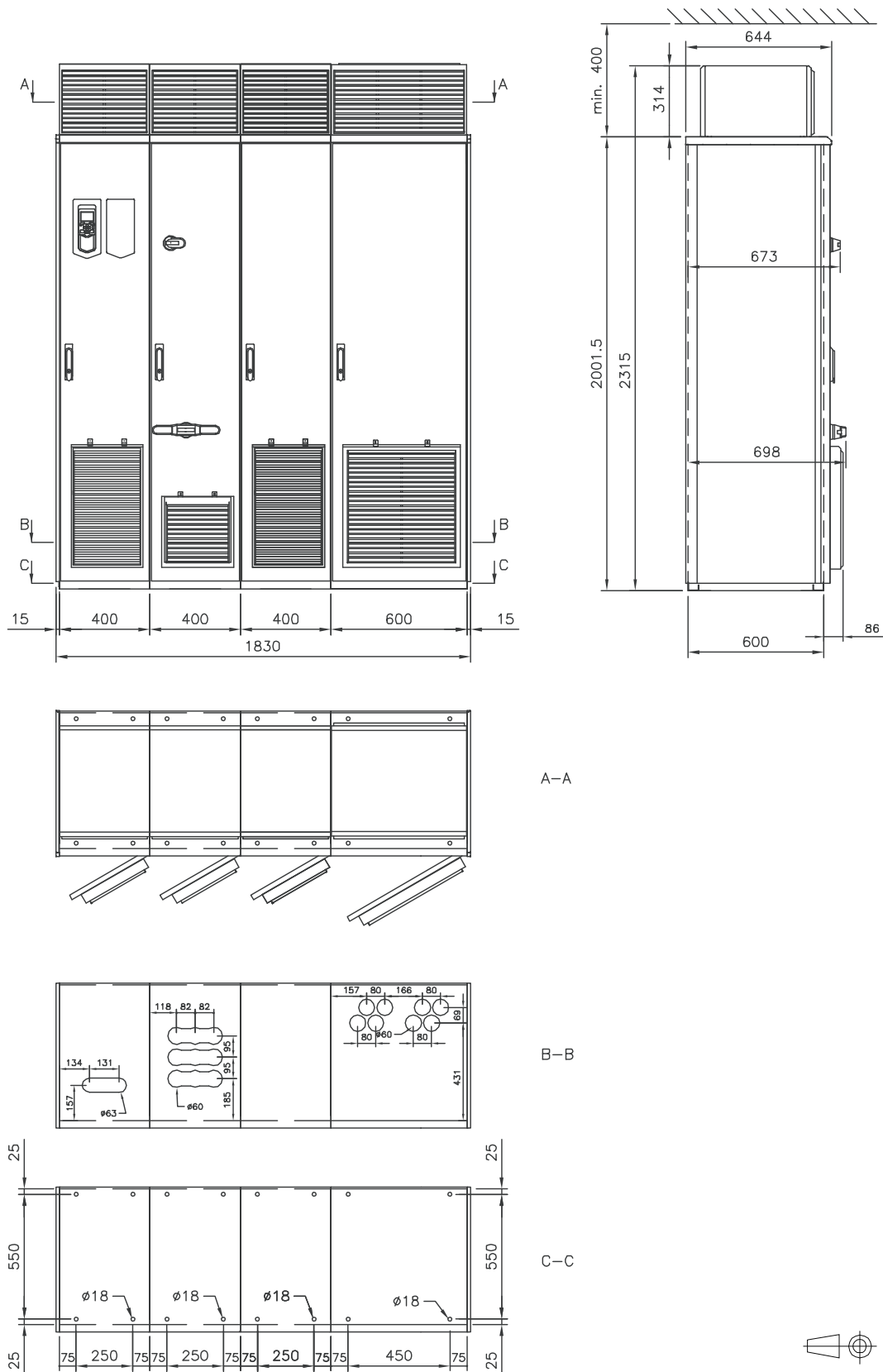

214 Dimensions

Frame 1xD8T + 2xR8i with common motor terminal cubicle (+H359), 1/2

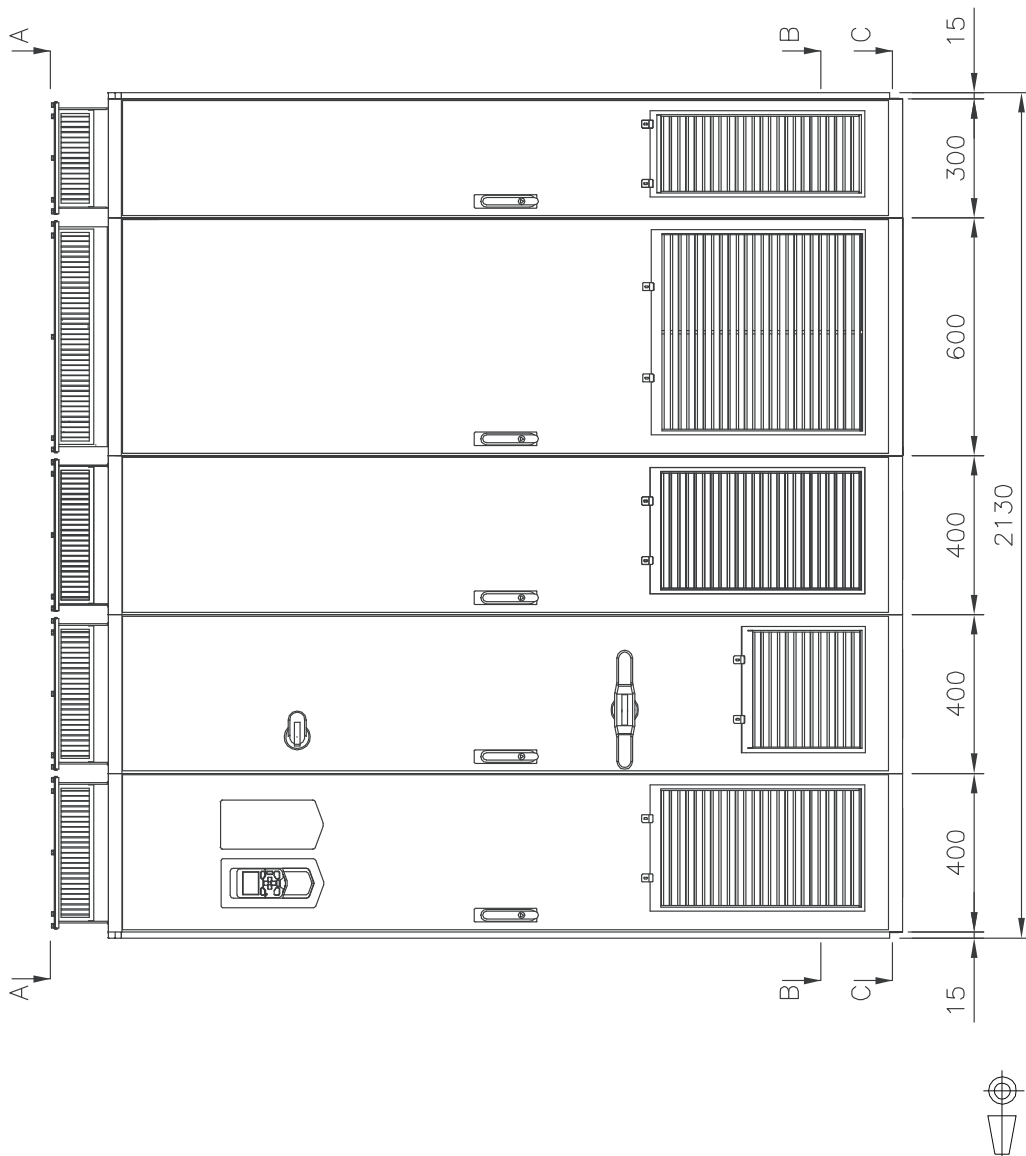
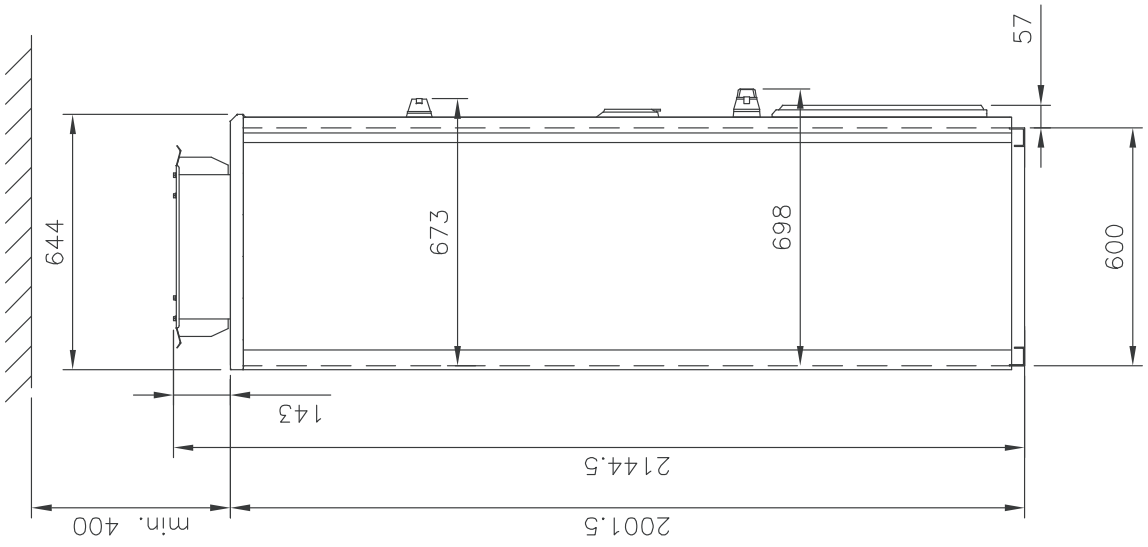

Frame 1×D8T + 2×R8i with brake choppers and resistors (+D150 +D151), 1/2

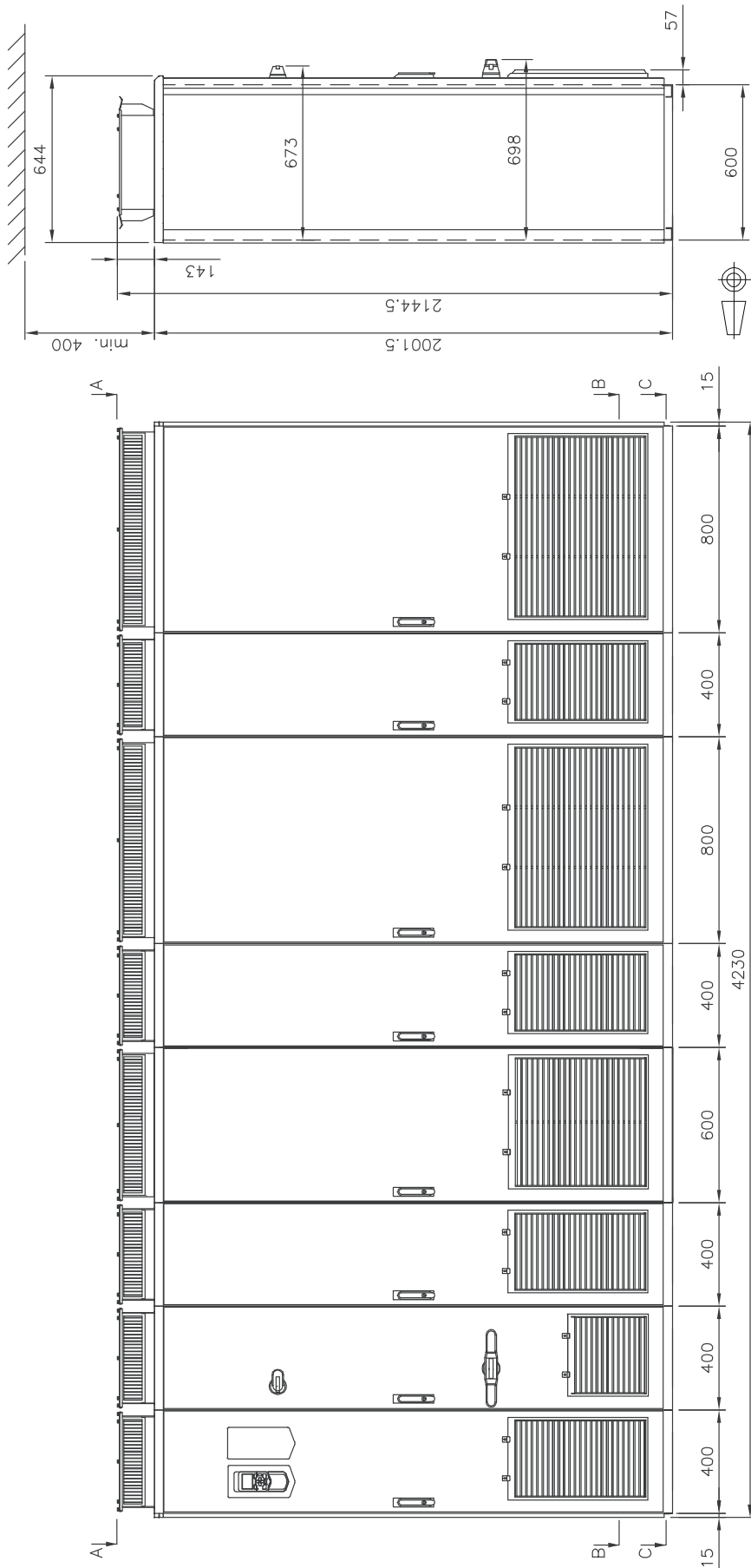

Frame 1xD8T + 2xR8i with sine output filter (+E206), 2/2

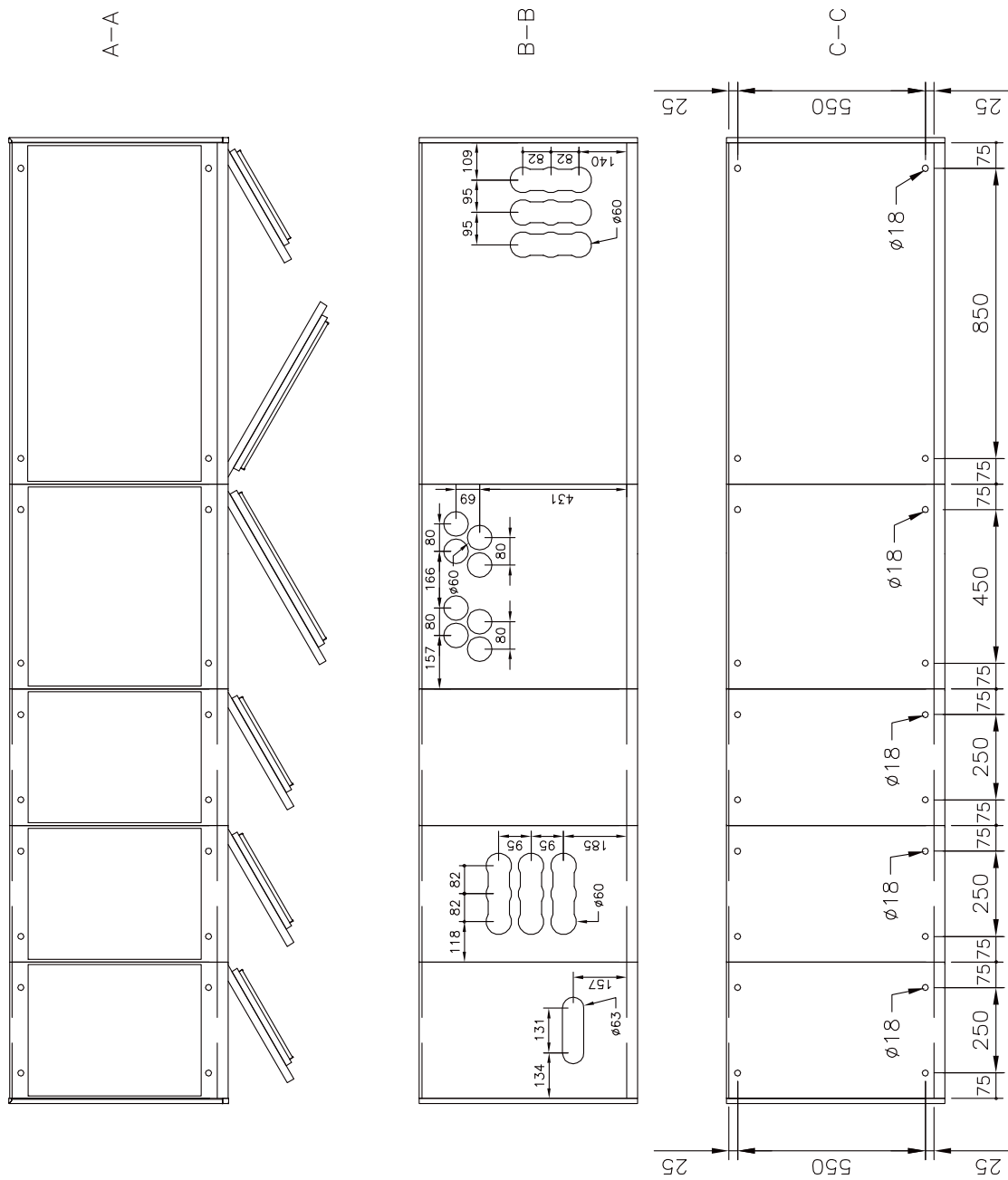

Frame 2×D8T + 2×R8i (12-pulse) with grounding switch (+F259)

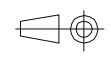
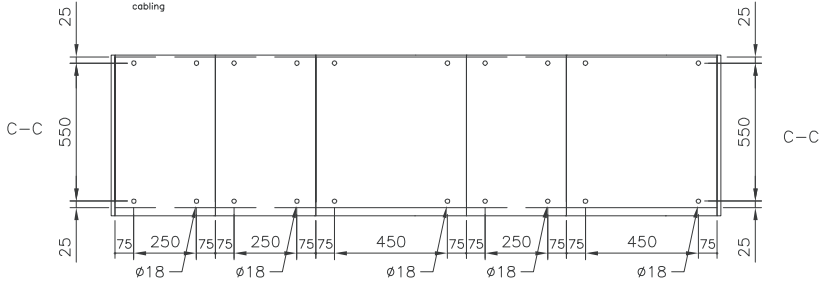
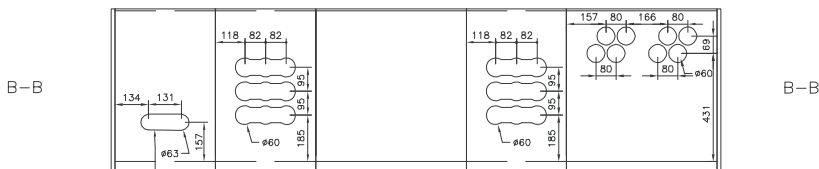
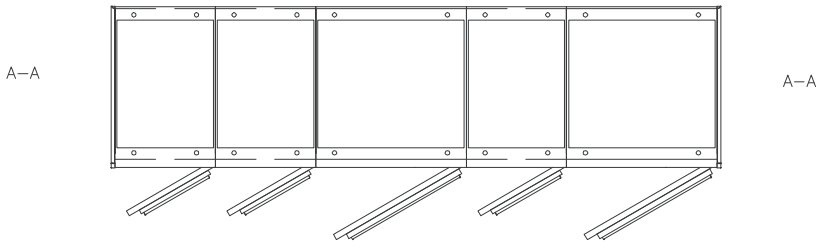
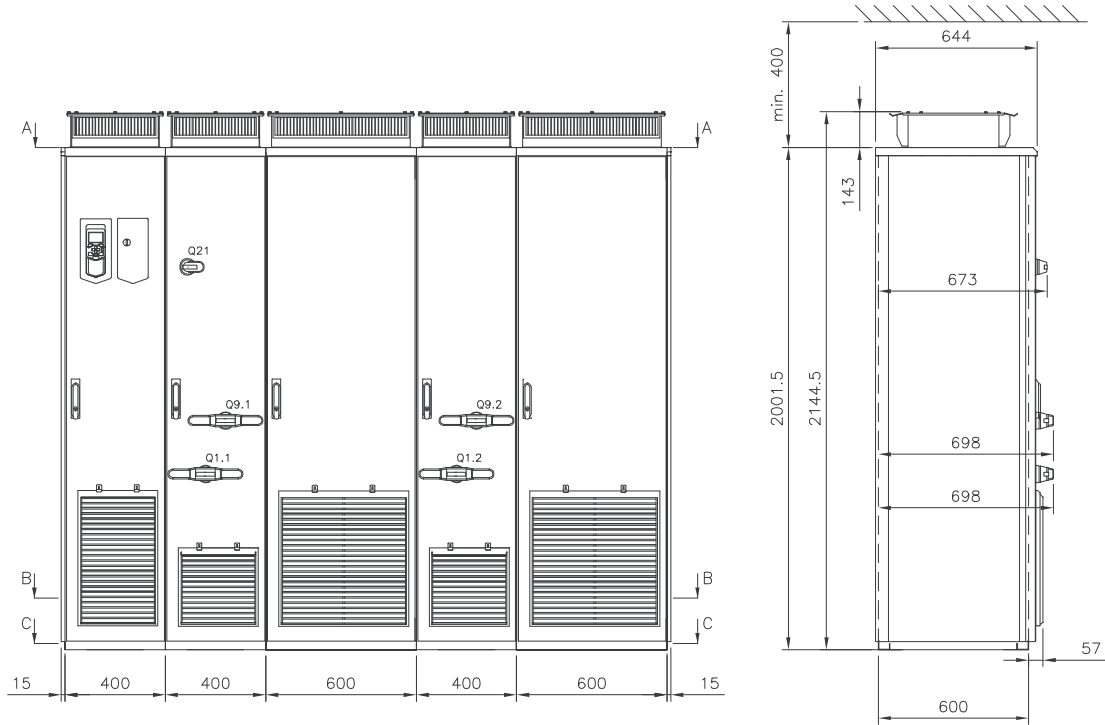

Frame 2xD8T + 3xR8i, 1/2

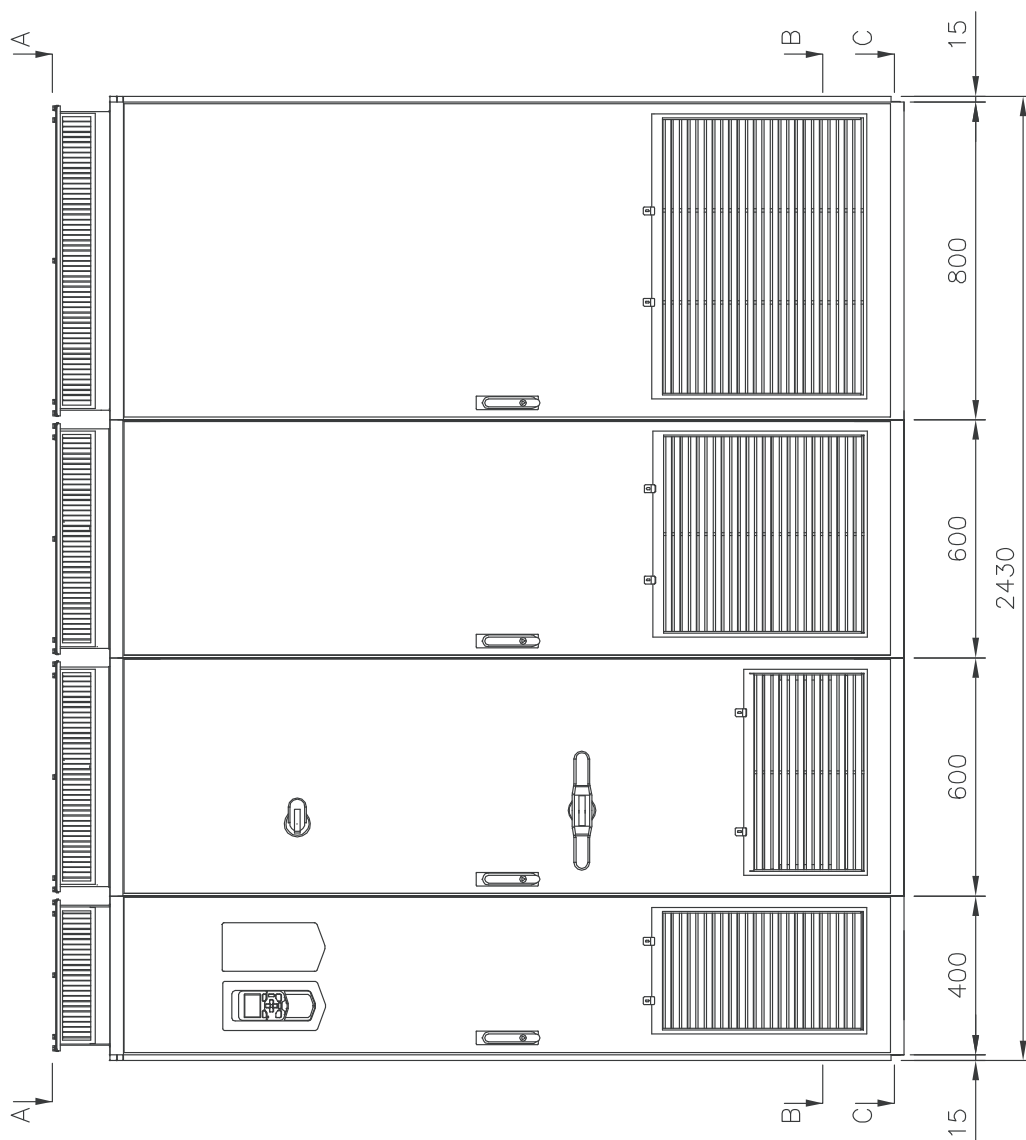
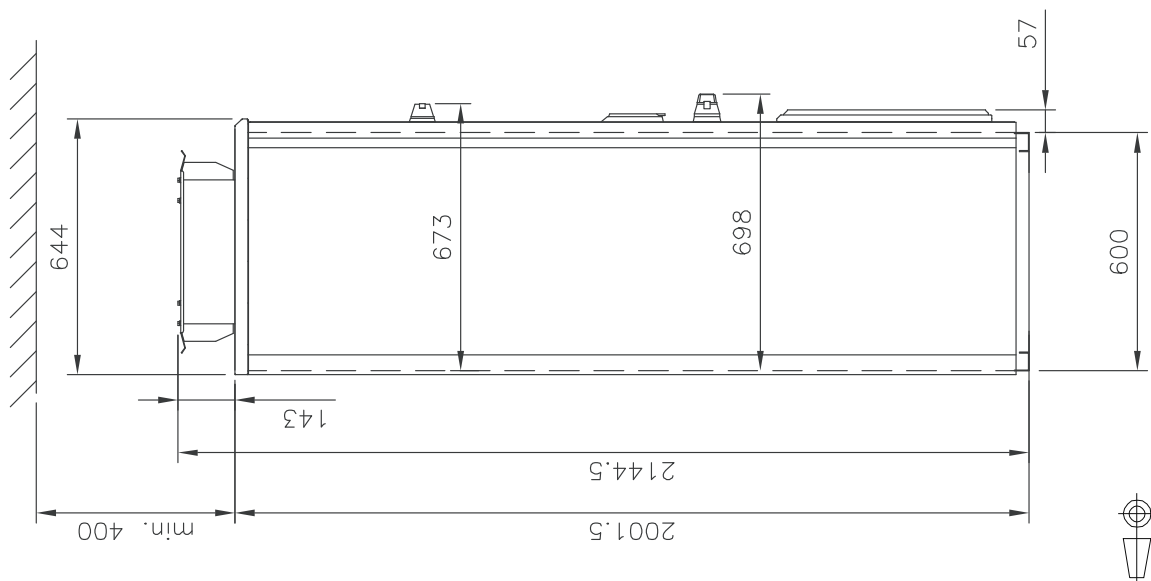

Frame 2×D8T + 3×R8i, 2/2

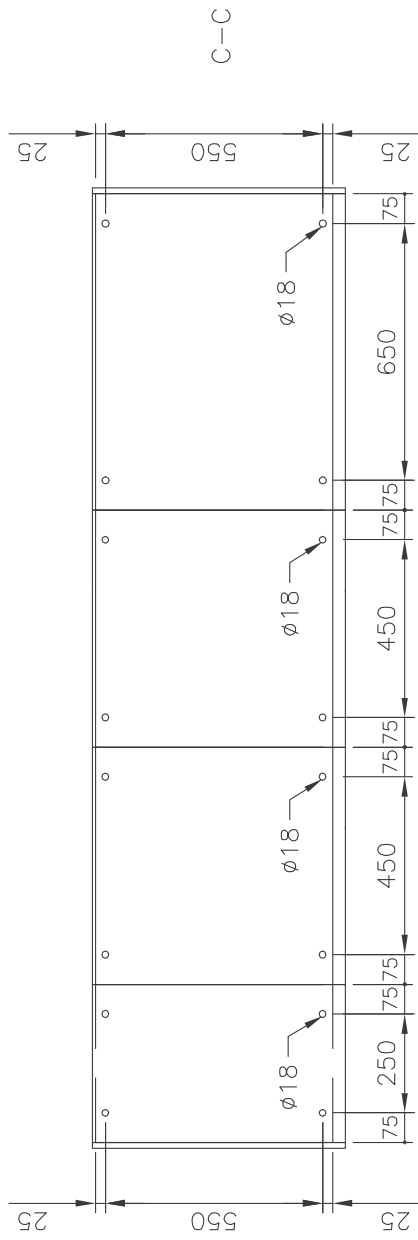
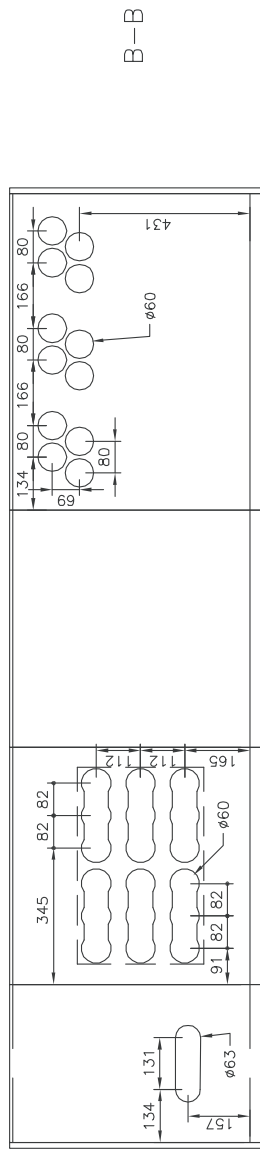
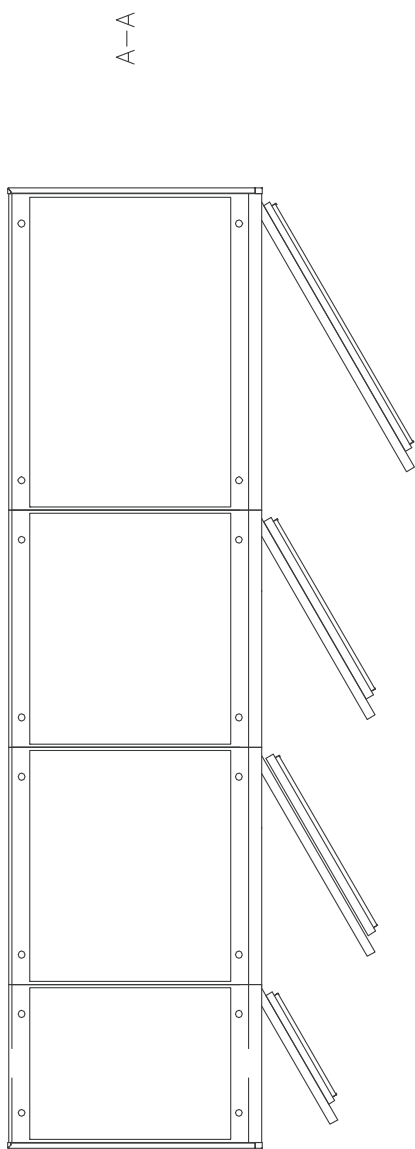

Frame 2xD8T + 3xR8i with common motor terminal cubicle (+H359), 1/2

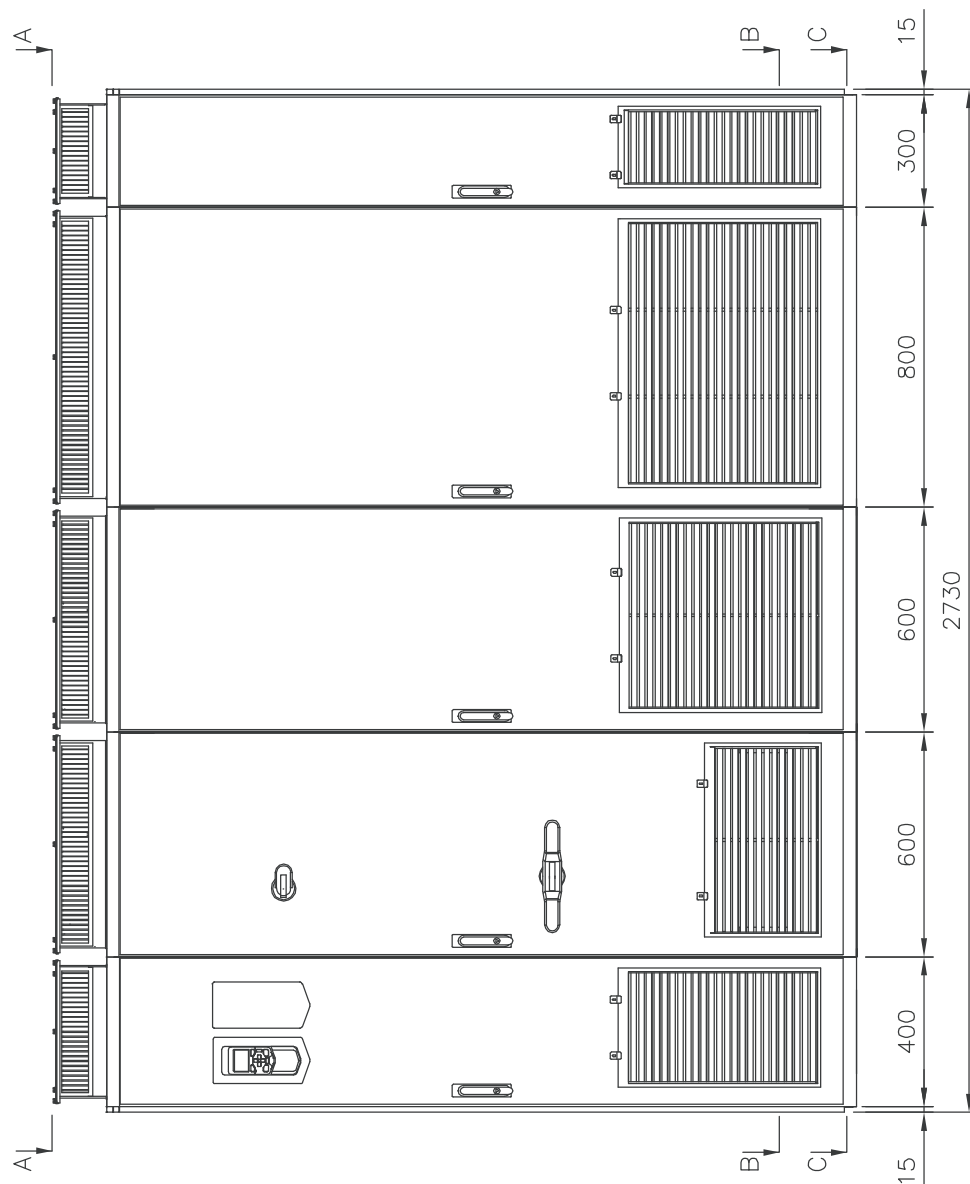
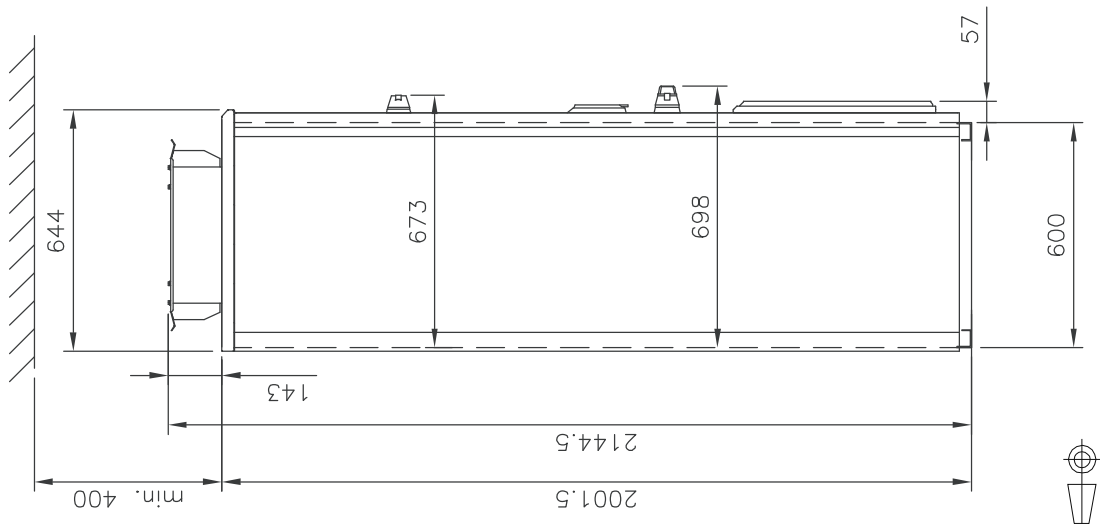

Frame 2×D8T + 3×R8i with common motor terminal cubicle (+H359), 2/2

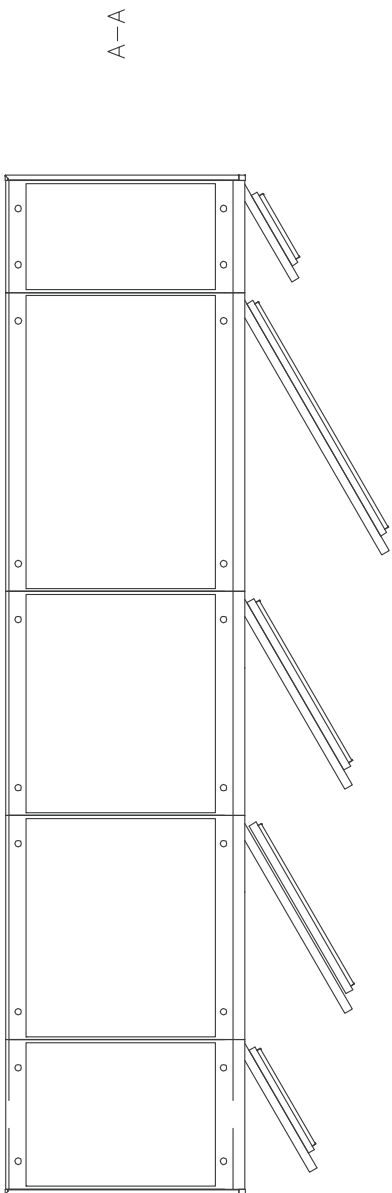

A-A

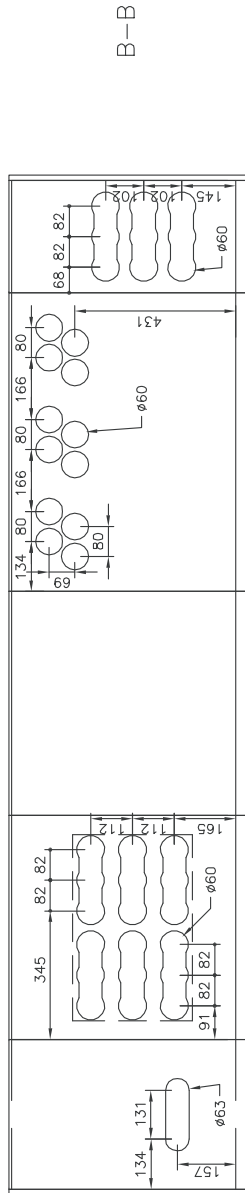

B-B

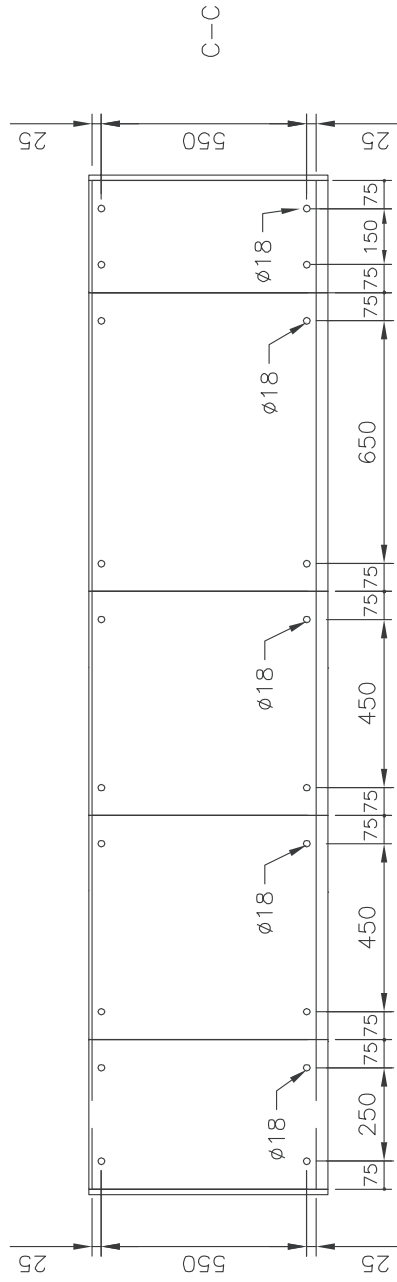

C-C

Frame 2xD8T + 3xR8i with top entry/top exit, 1/2

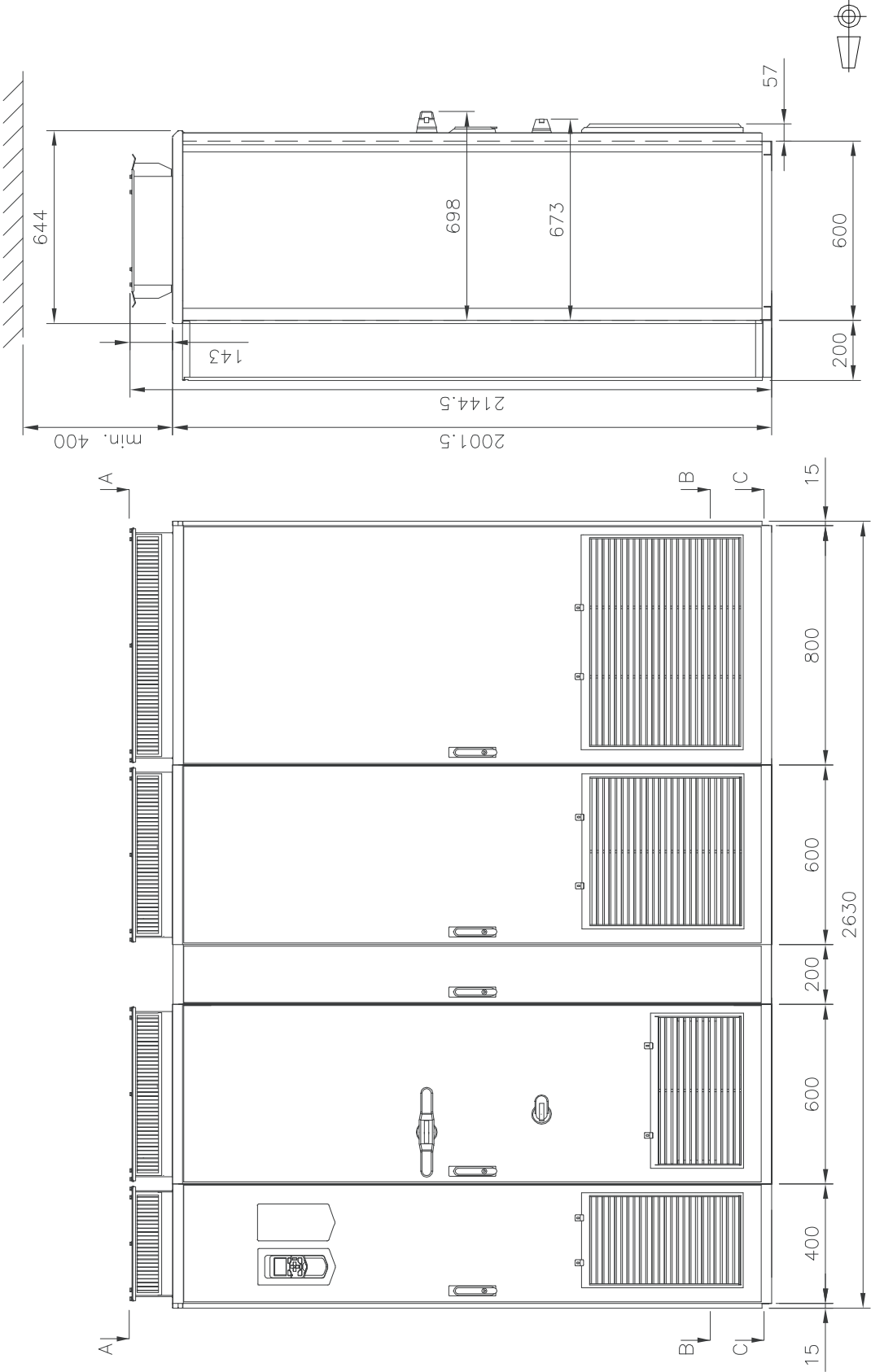

Frame 3xD8T + 4xR8i, 1/2

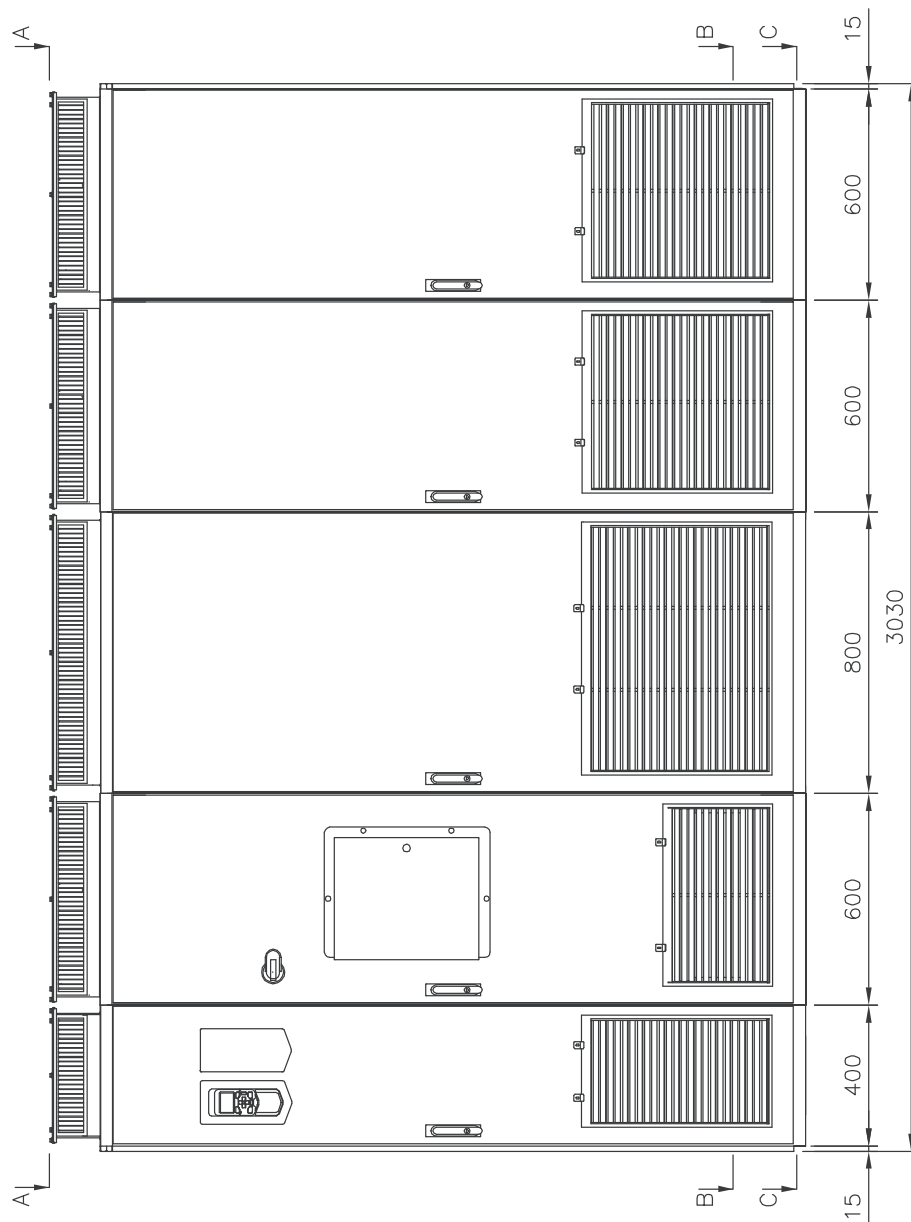
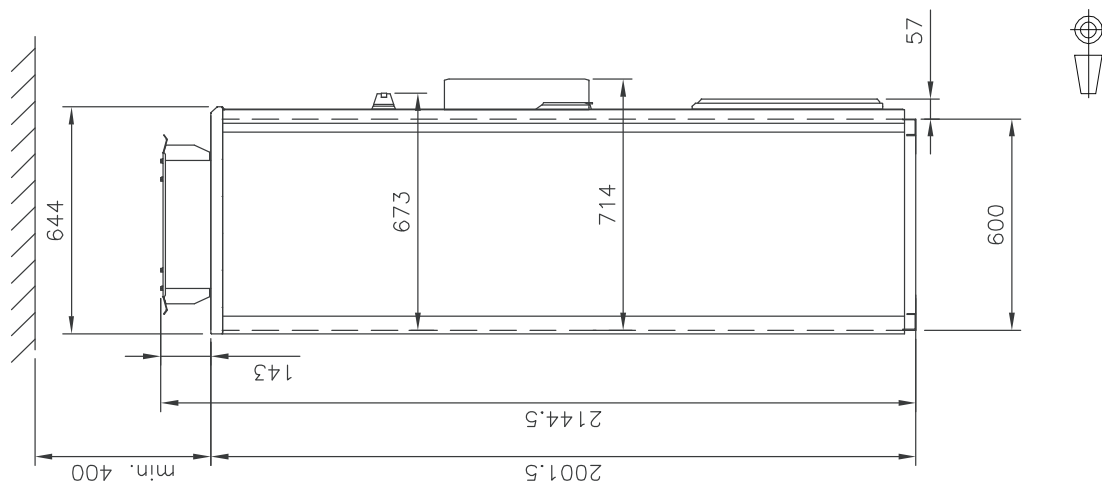

Frame 3×D8T + 4×R8i, 2/2

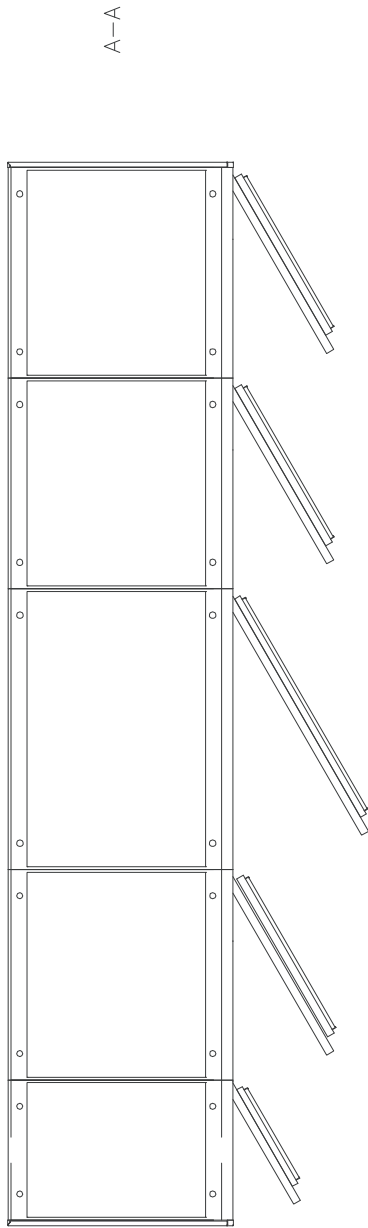

A-A

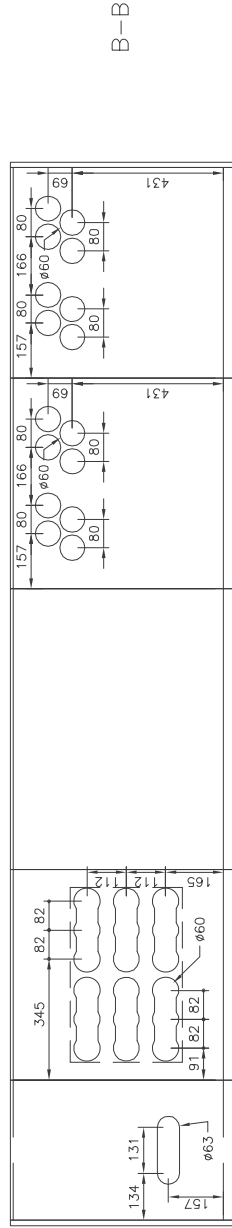

B-B

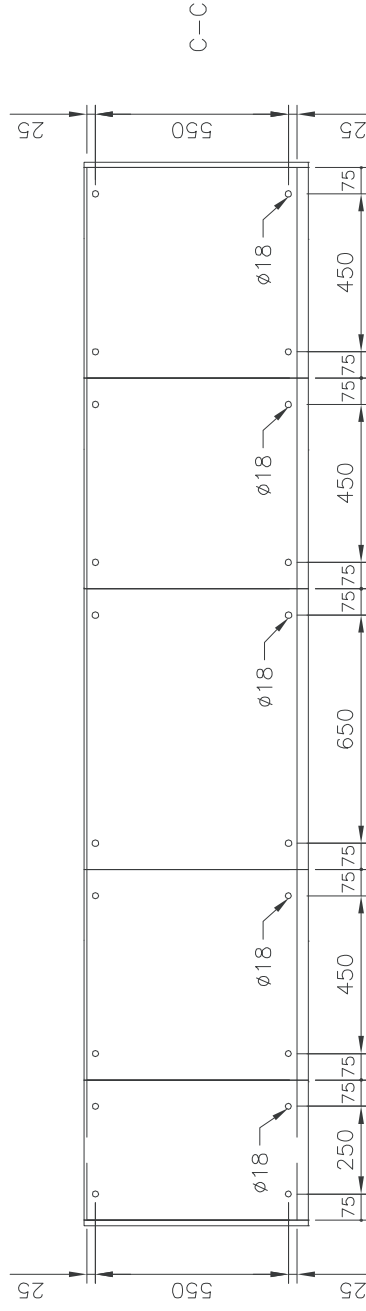

C-C

Frame 3×D8T + 4×R8i with common motor terminal cubicle (+H359), 1/2

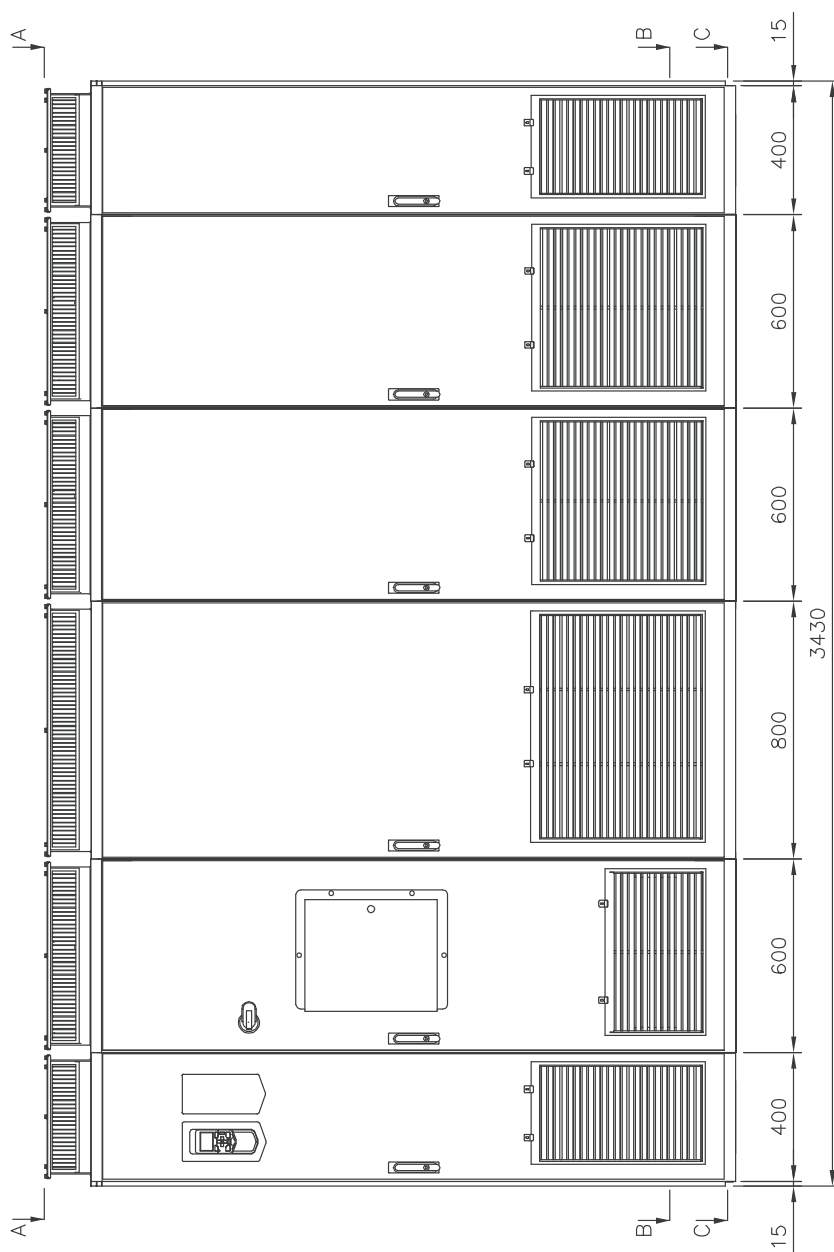
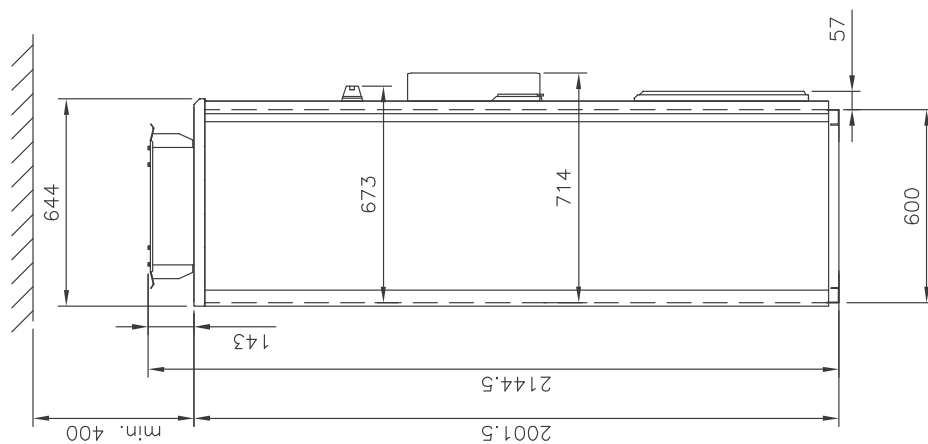

Frame 3×D8T + 4×R8i with common motor terminal cubicle (+H359), 2/2

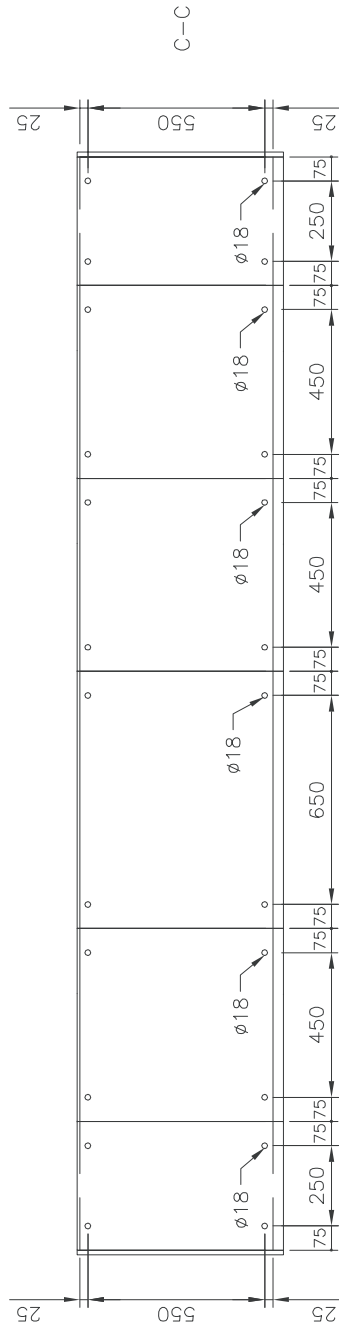
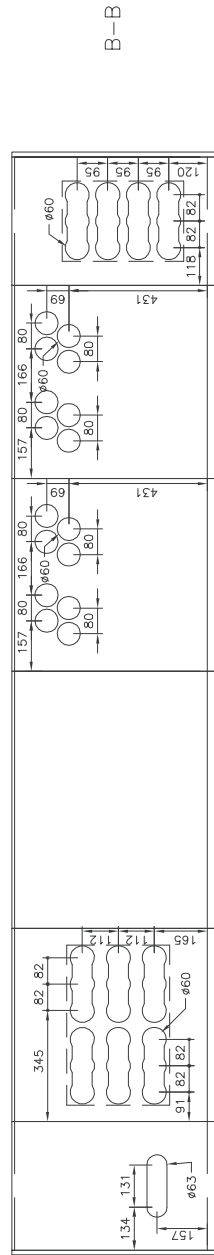
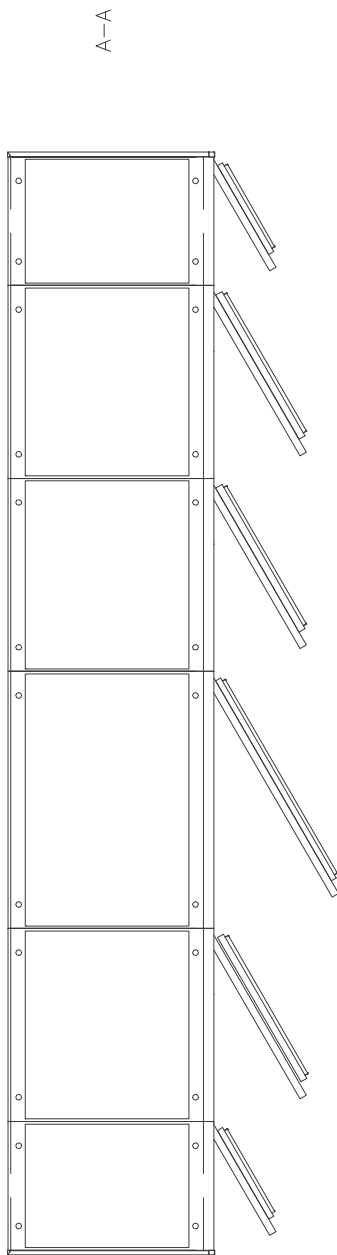

Frame 4xD8T + 5xR8i (6-pulse) with top entry/exit, UL Listed (+C129), 1/2

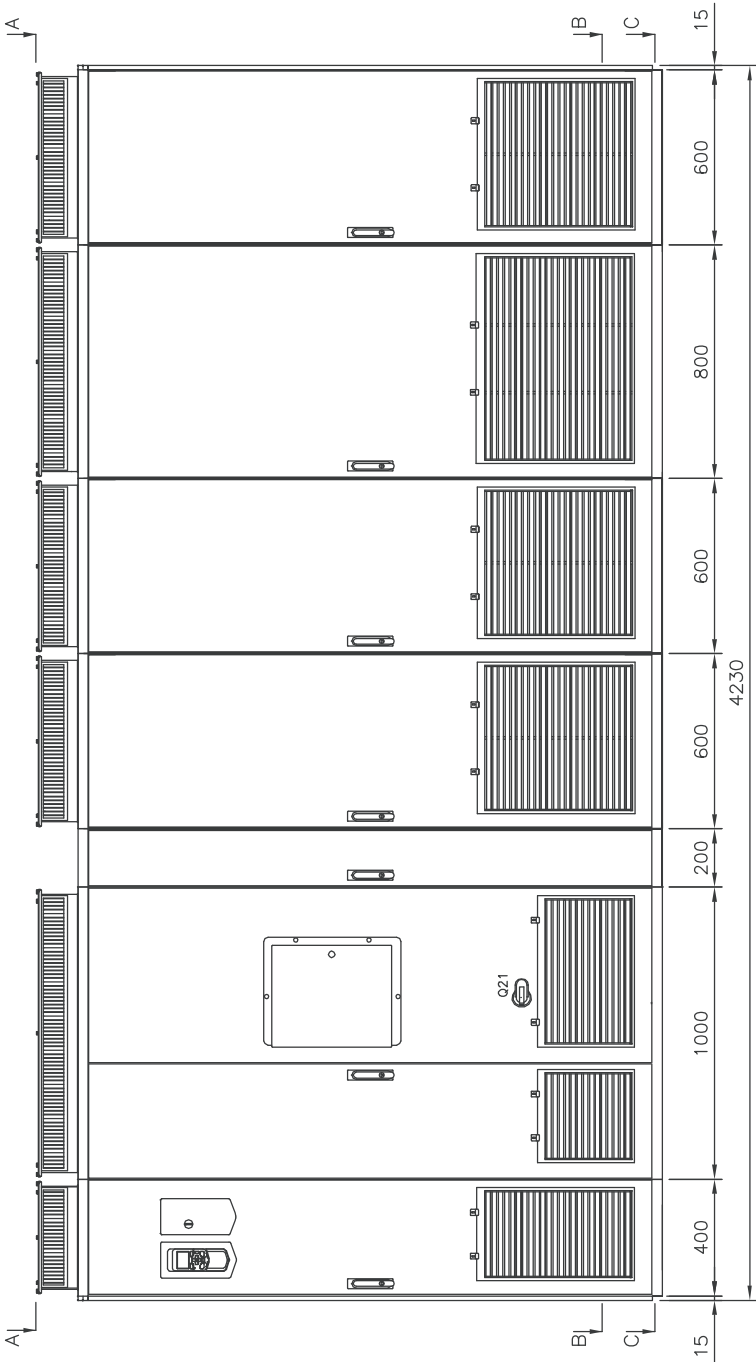
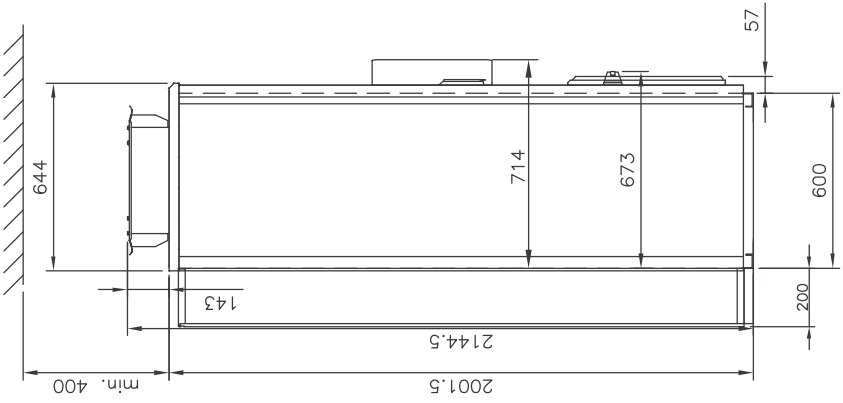

Location and size of input terminals

Note: See the dimension tables starting on page 203 as to which incoming cubicles are used with which drive type and options.

■ 400 mm, bottom cable entry

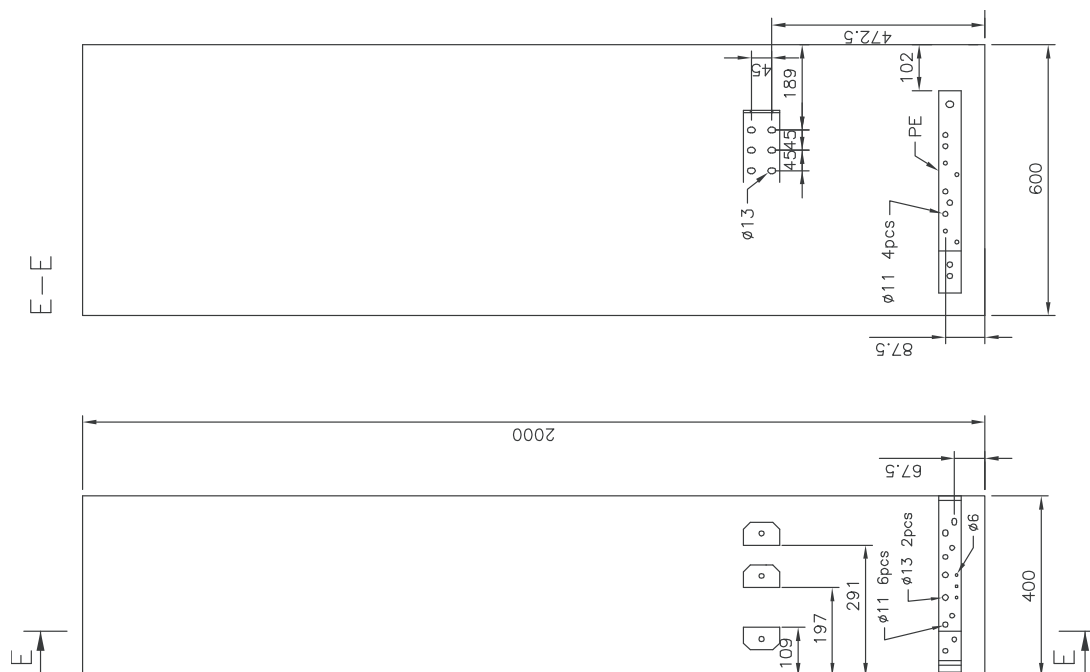

■ 400 mm, top cable entry

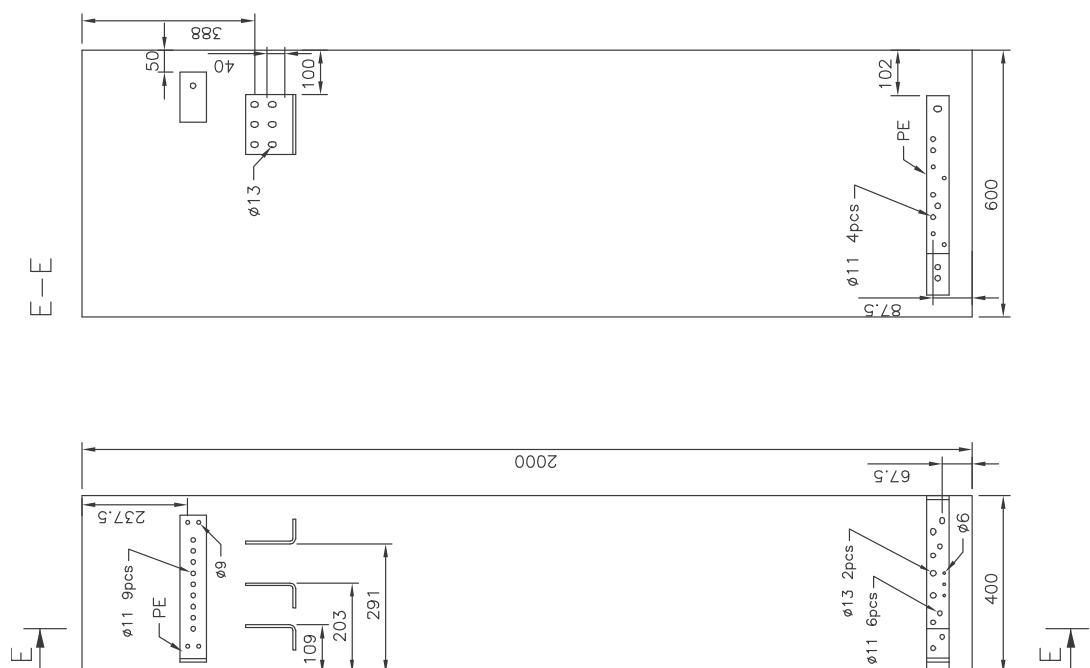

- 600 mm, without main breaker, bottom cable entry (including 12-pulse units with grounding switch)

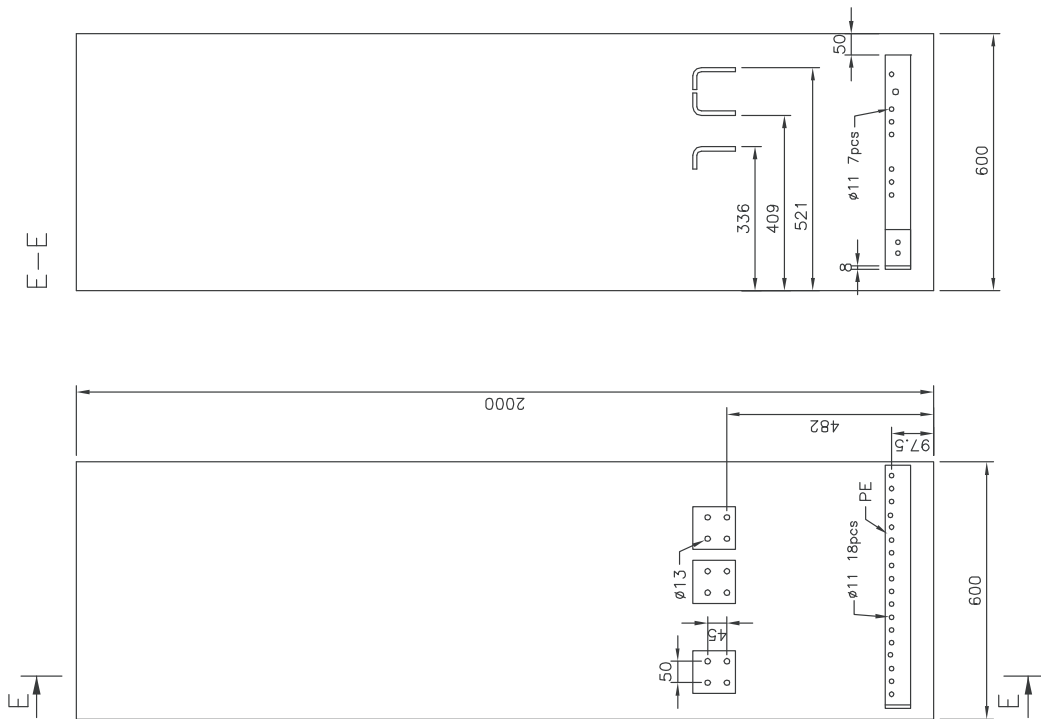

- 600 mm, without main breaker, top cable entry (including 12-pulse units with grounding switch)

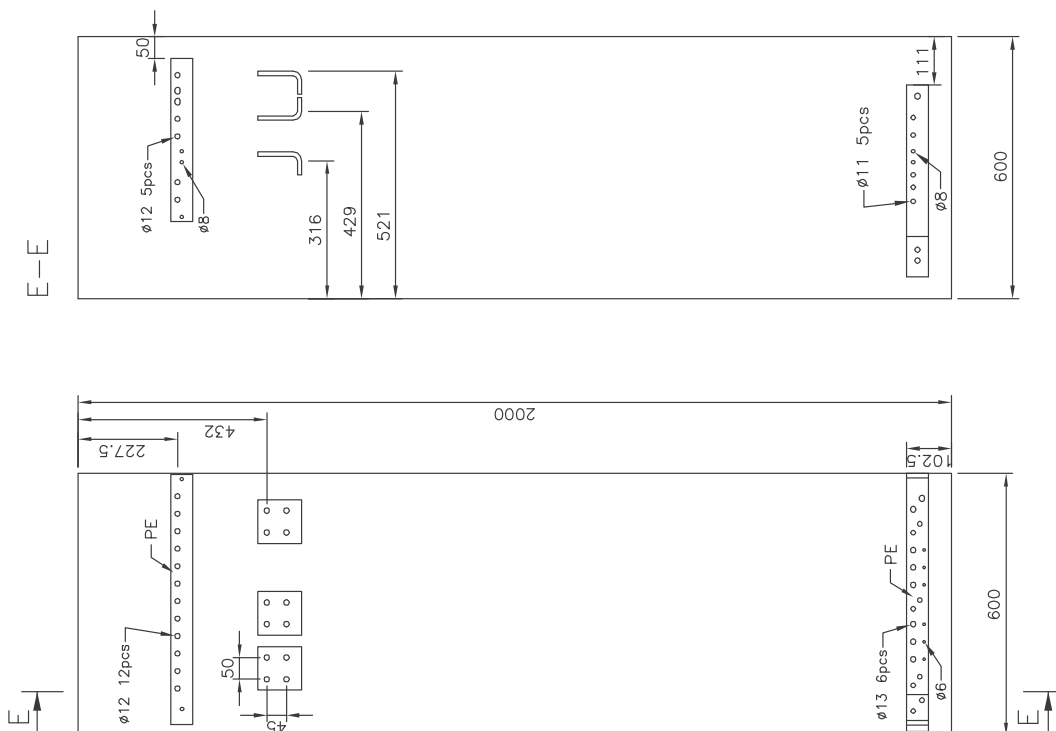

■ 600 mm, 12-pulse units without grounding switch, bottom cable entry

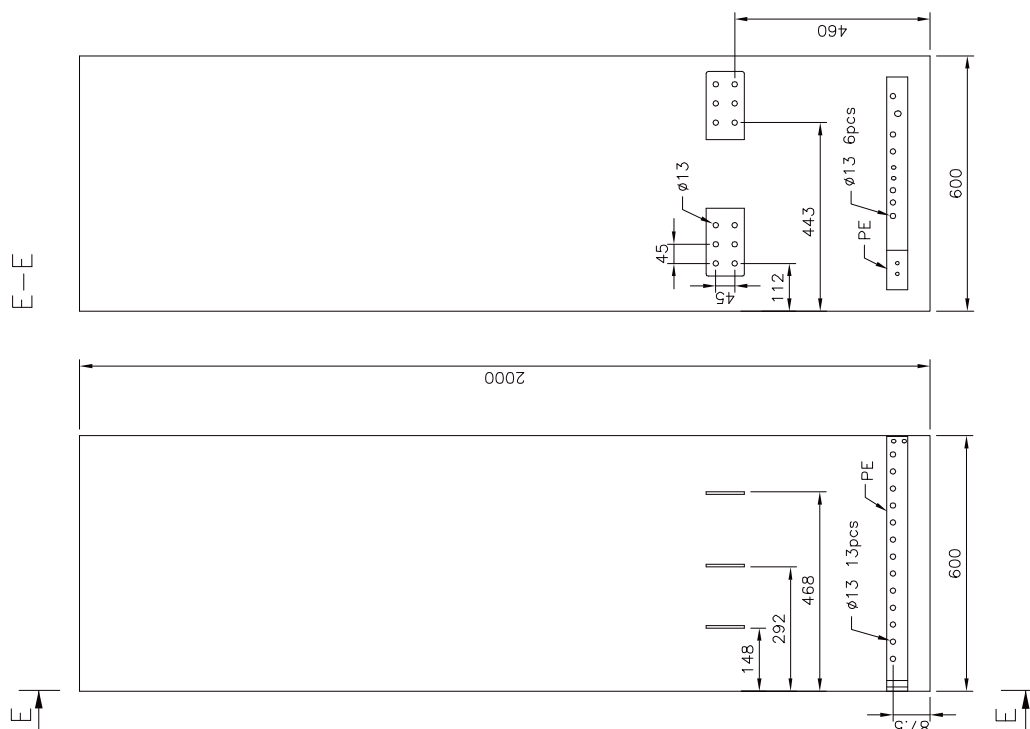

■ 600 mm, 12-pulse units without grounding switch, top cable entry

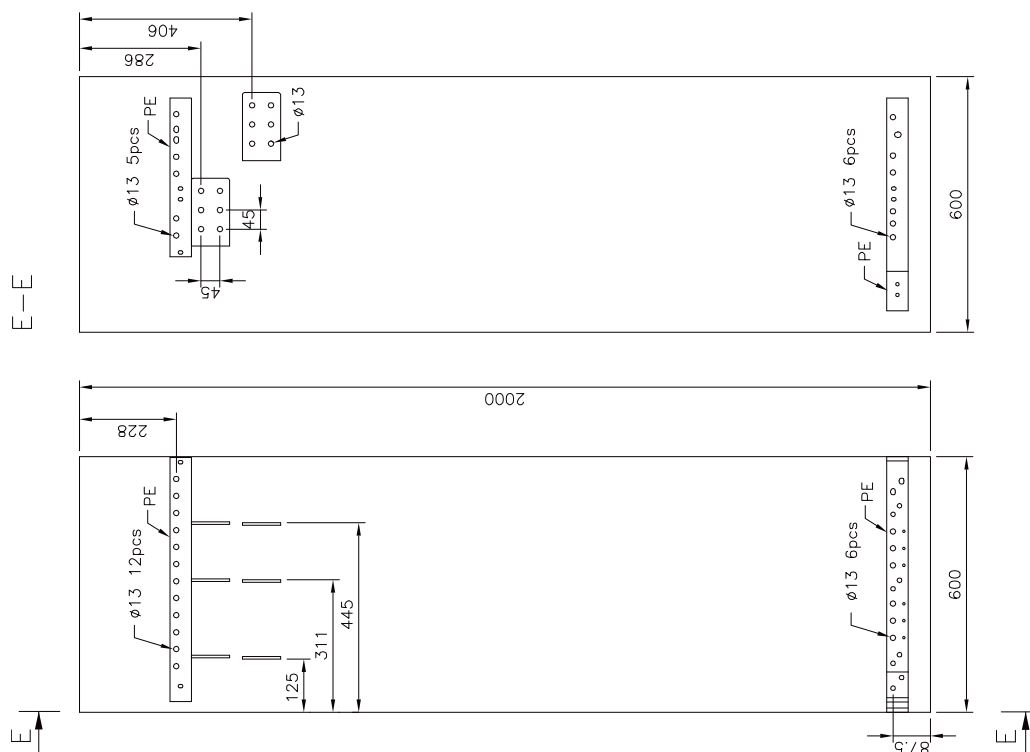

■ 600 mm, with main breaker, bottom cable entry

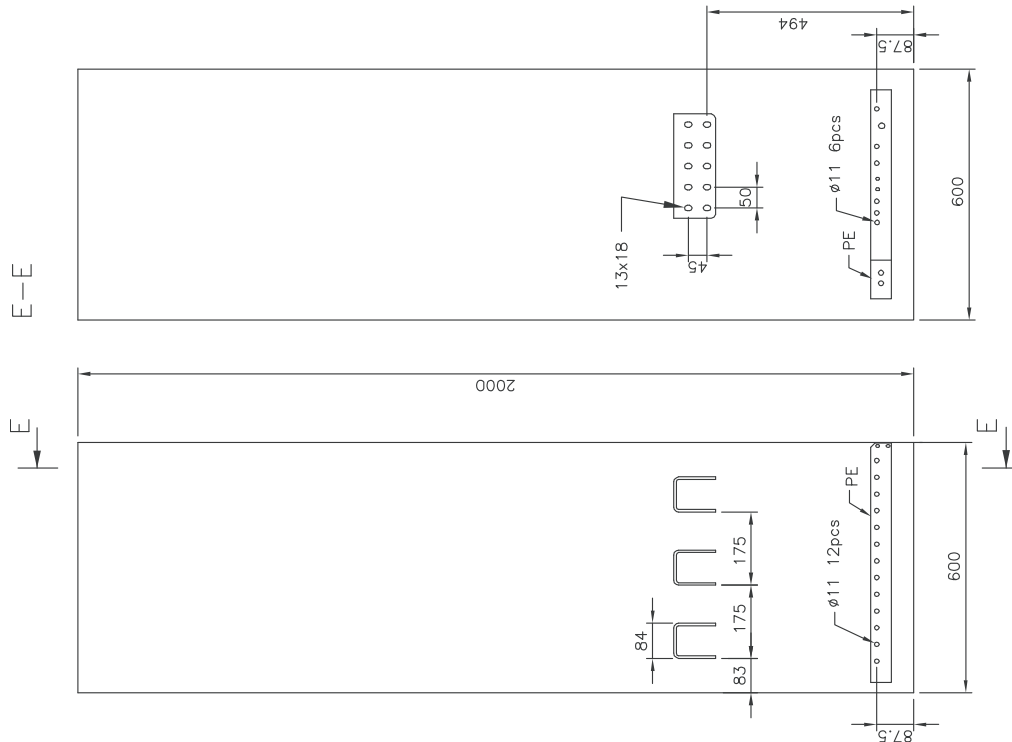

■ 600 mm, with main breaker, top cable entry

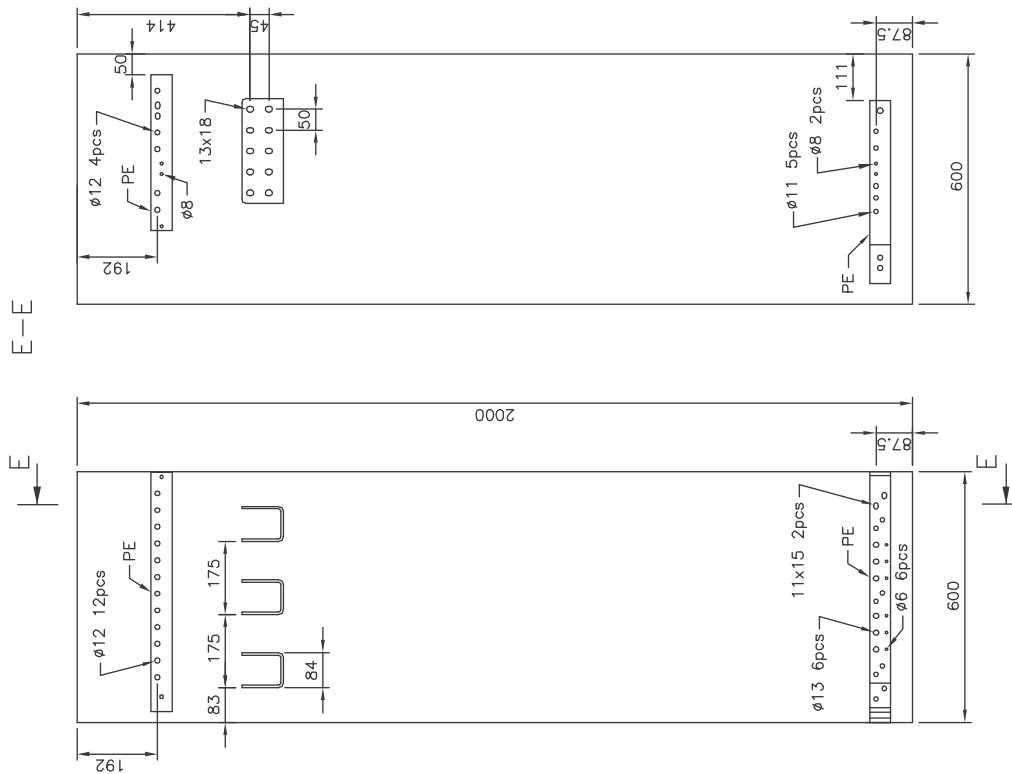

■ 1000 mm (UL/CSA), top cable entry

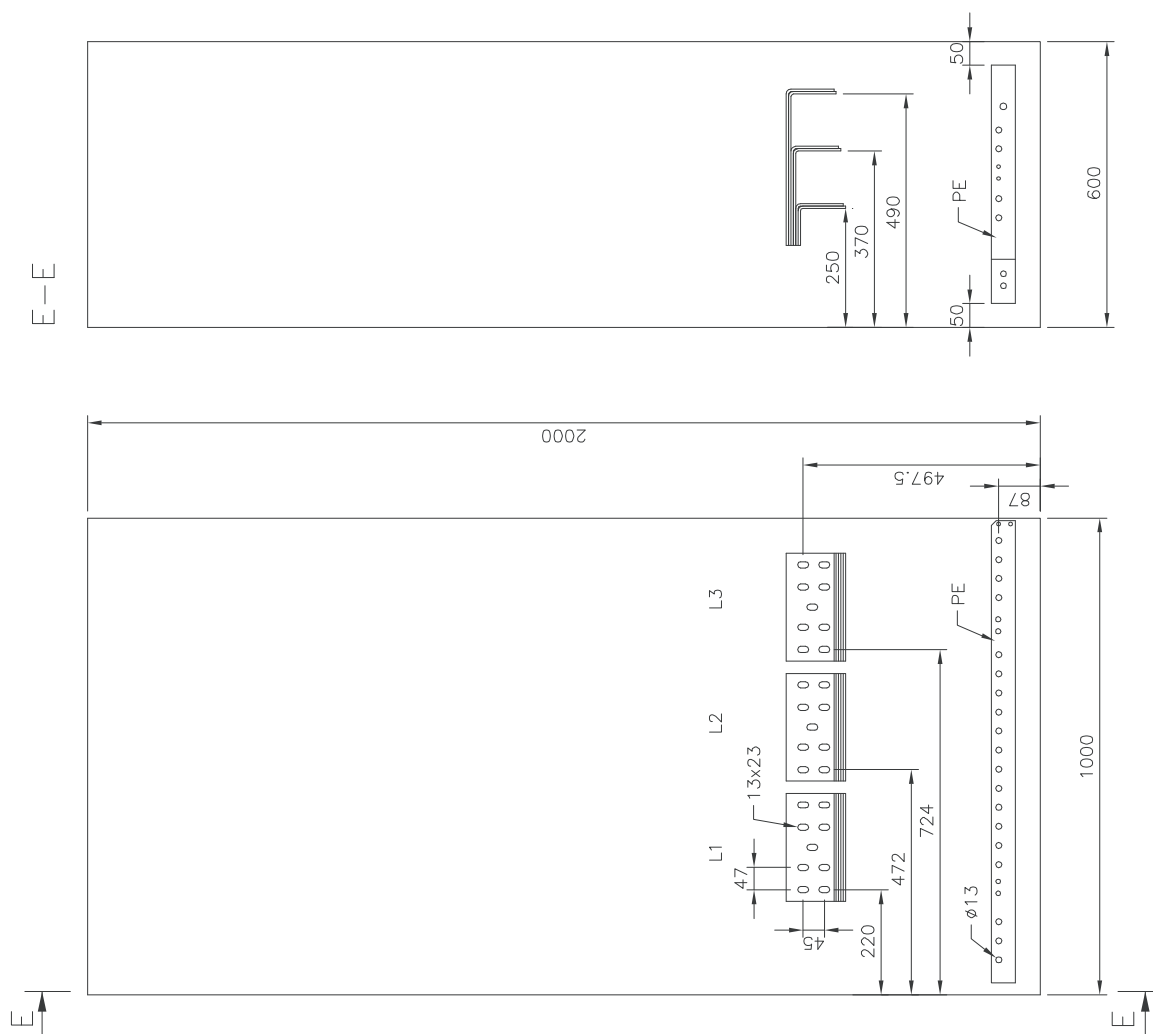

■ 1000 mm (UL/CSA), bottom cable entry



Location and size of output terminals (units without common motor terminal cubicle)

■ Inverter module cubicle with two modules, bottom cable exit

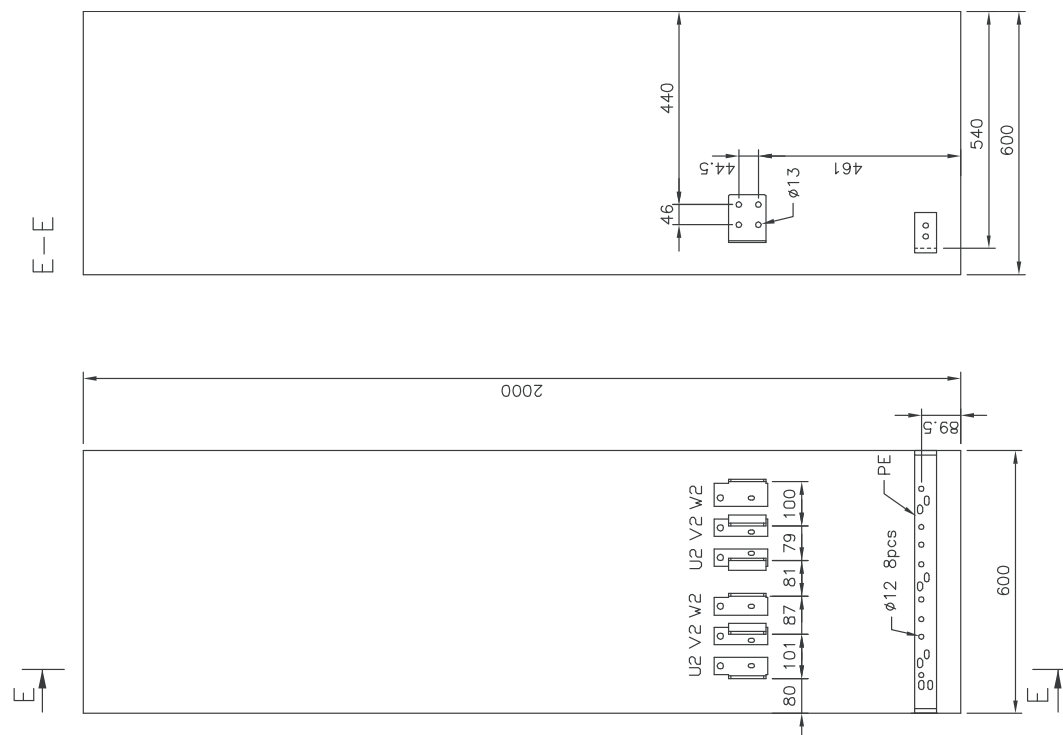

■ Inverter module cubicle with two modules, top cable exit

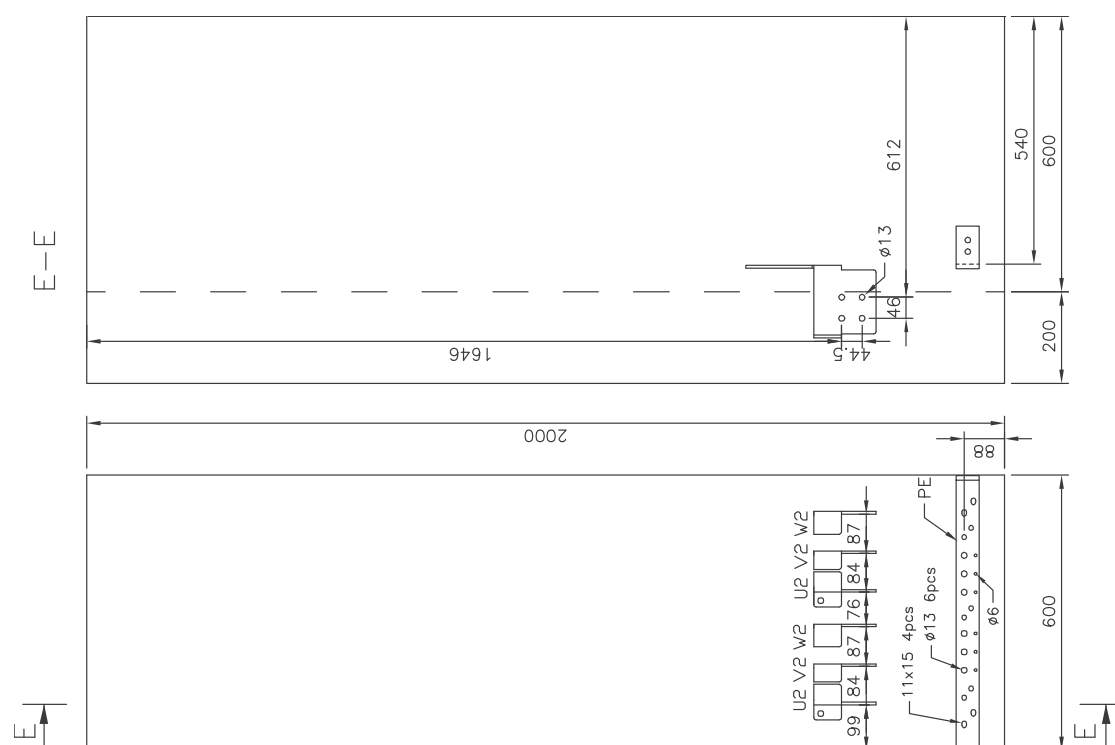

■ Inverter module cubicle with three modules, bottom cable exit

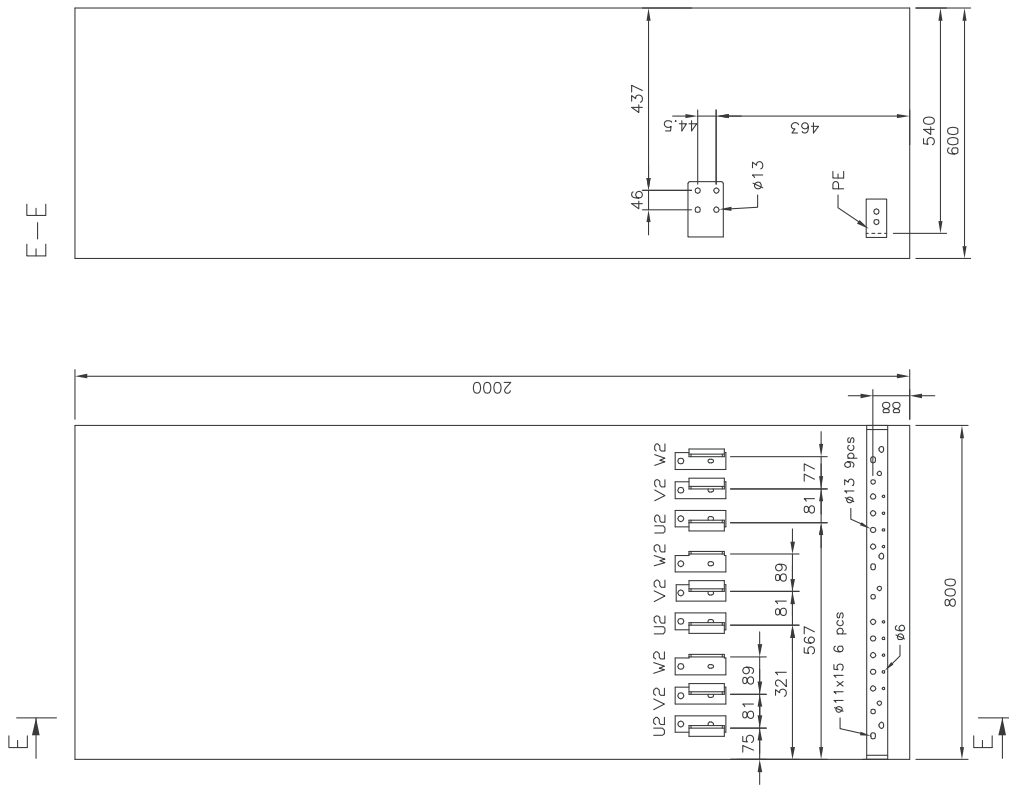

■ Inverter module cubicle with three modules, top cable exit

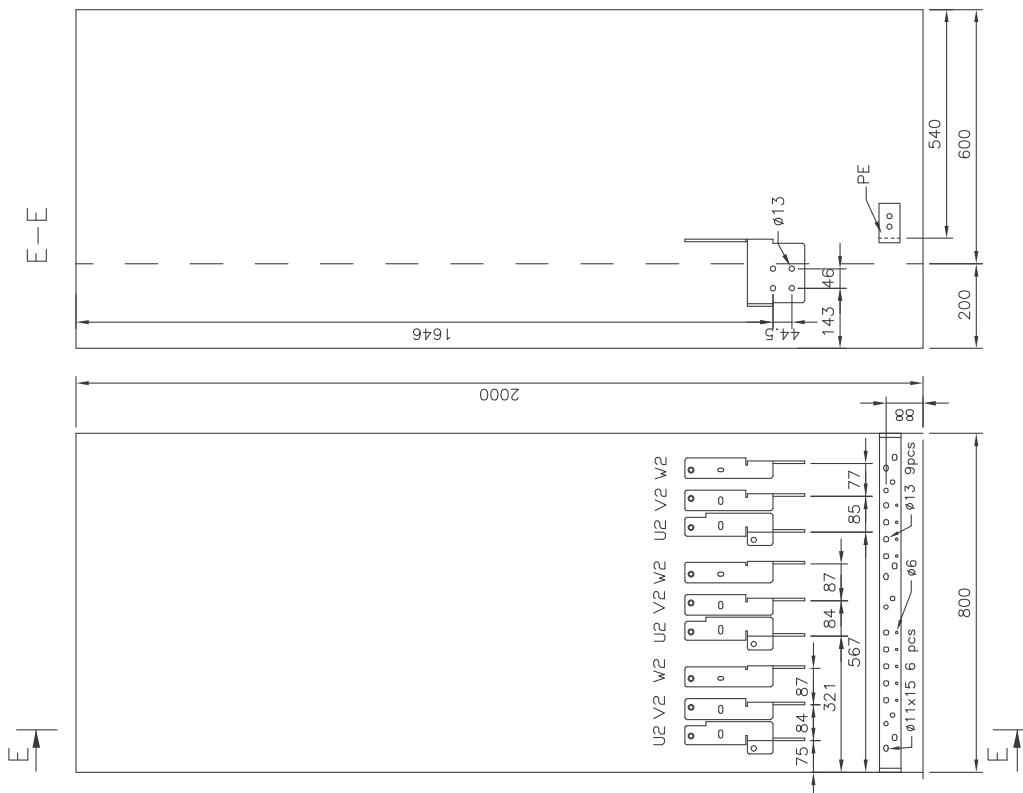

■ Sine filter cubicle (+F206), bottom cable exit

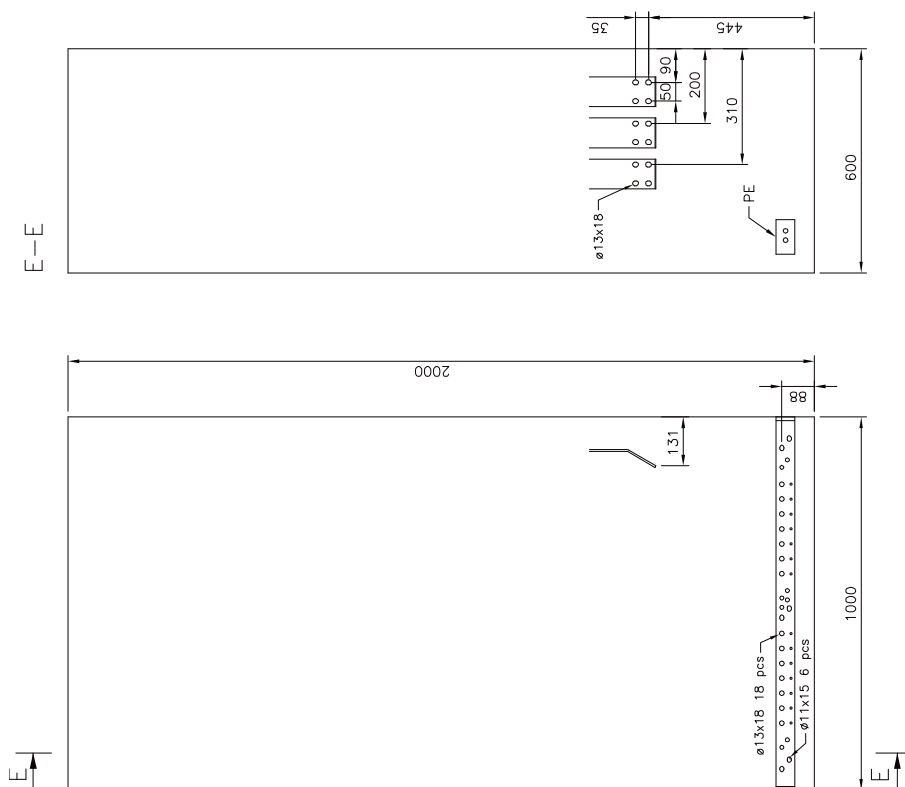

■ Sine filter cubicle (+F206), top cable exit

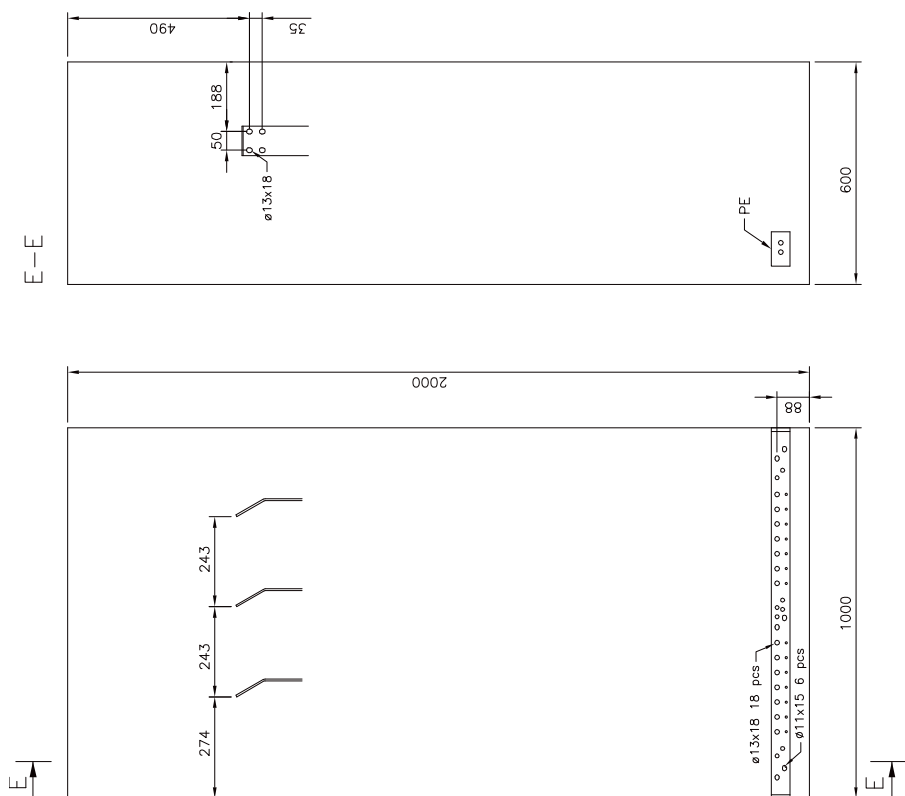

■ Brake chopper cubicle

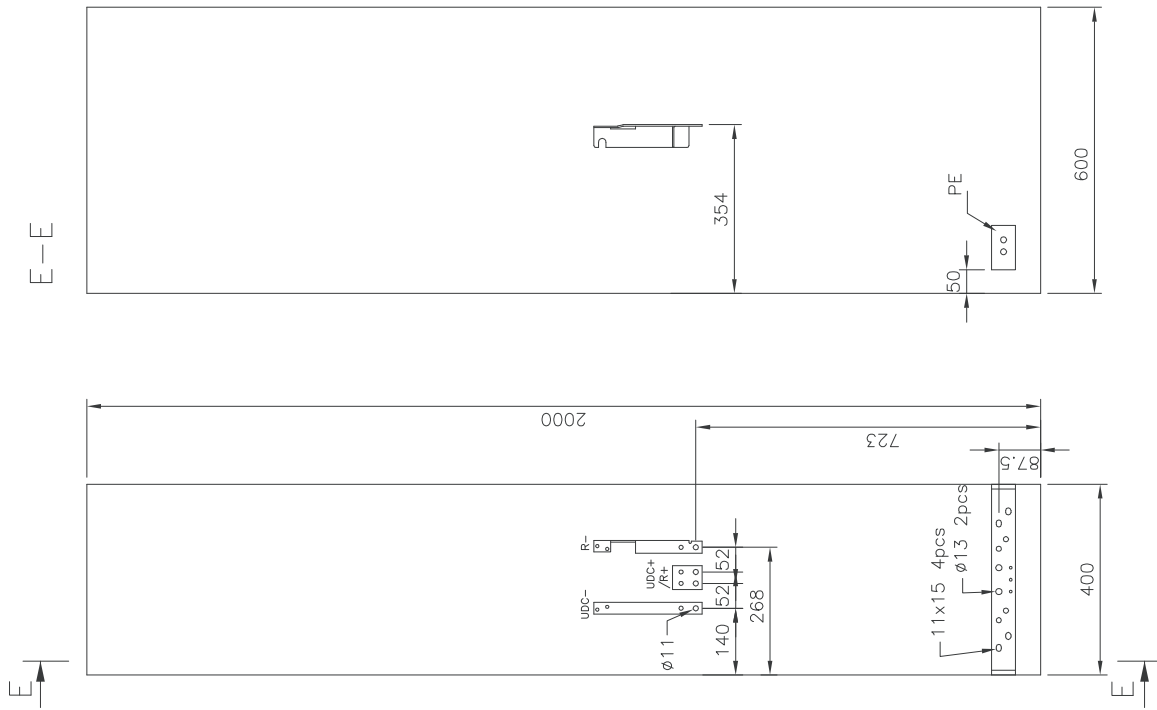

Location and size of output terminals (units with common motor terminal cubicle)

Note: See the dimension tables starting on page 203 as to which common motor terminal cubicle width is used with which drive type.

■ **Cubicle width 300 mm, bottom cable exit**

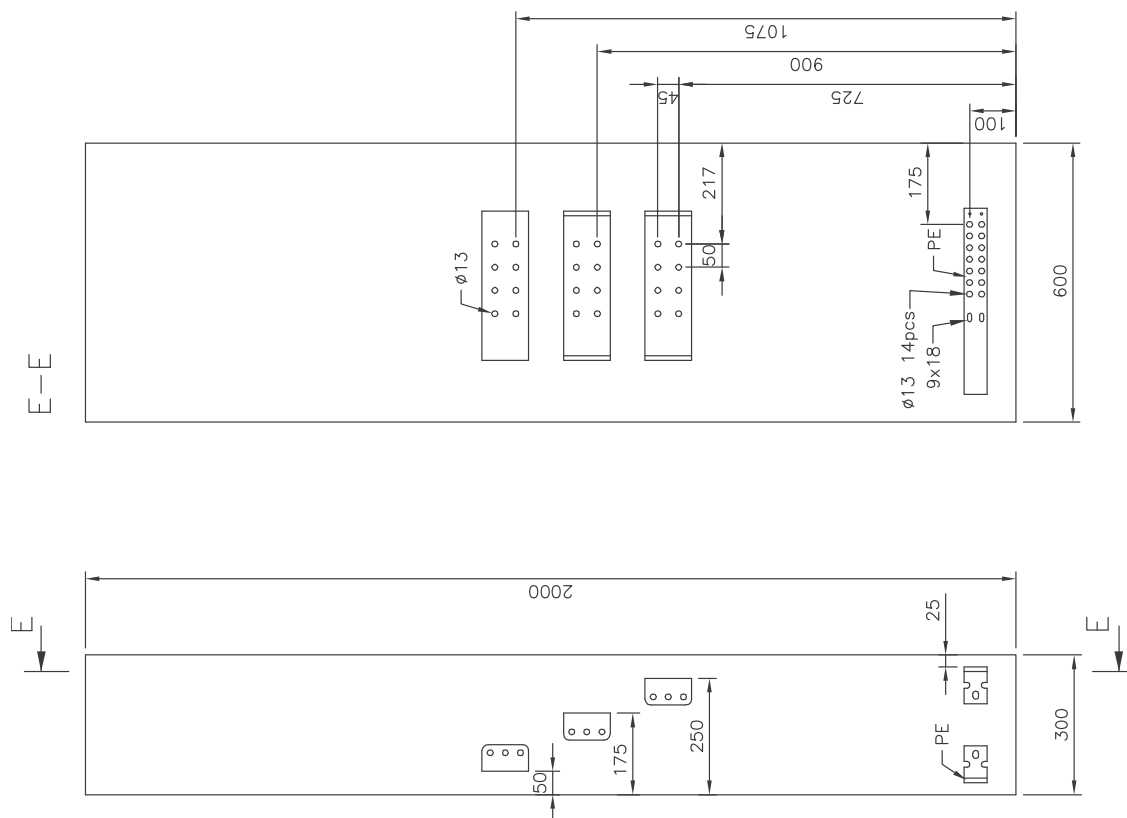

■ Cubicle width 400 mm, bottom cable exit

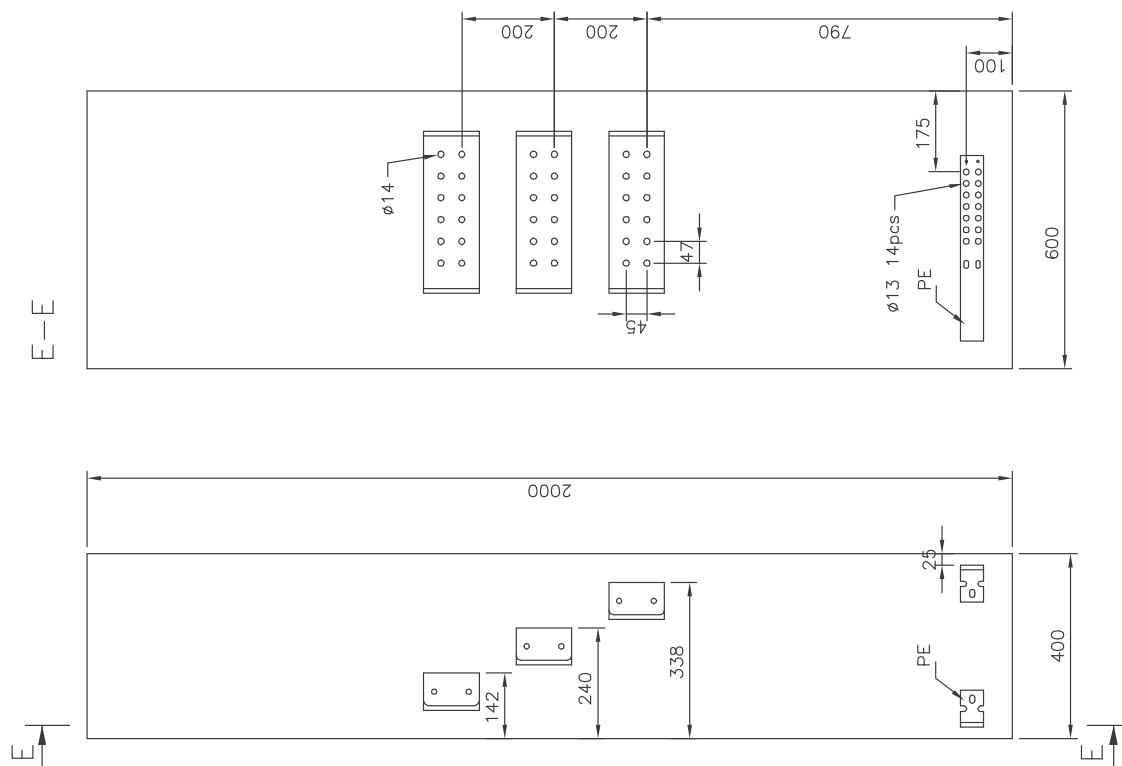

■ Cubicle width 400 mm, top cable exit

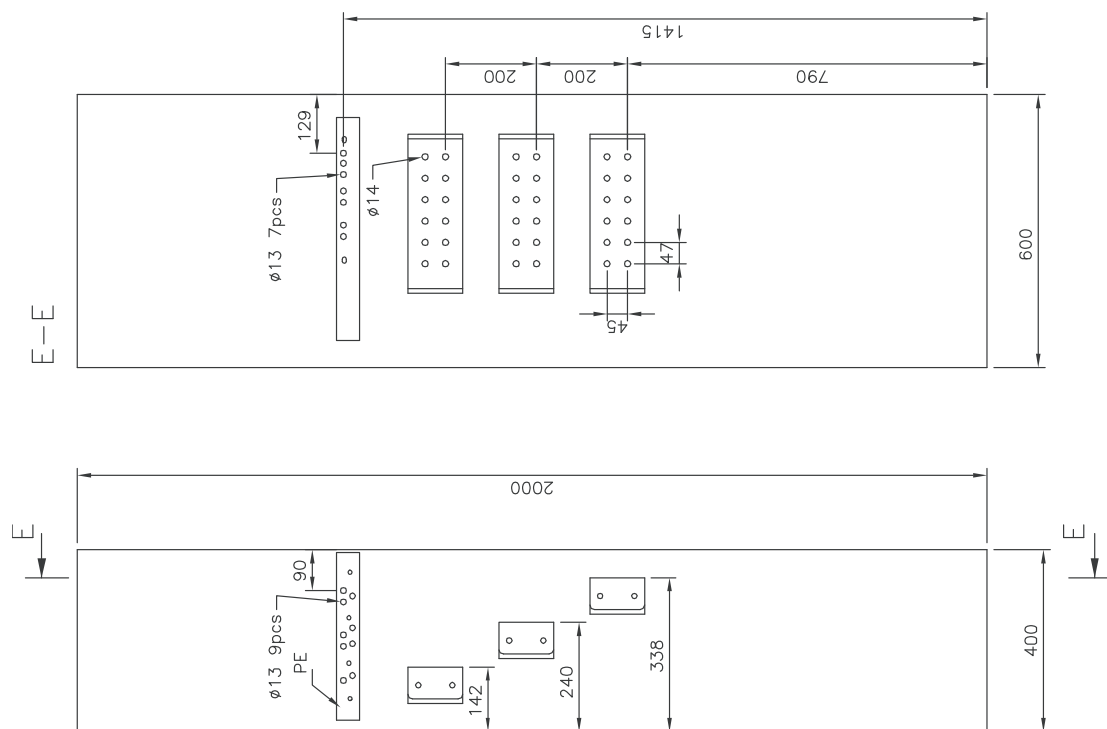

■ Cubicle width 600 mm, bottom cable exit

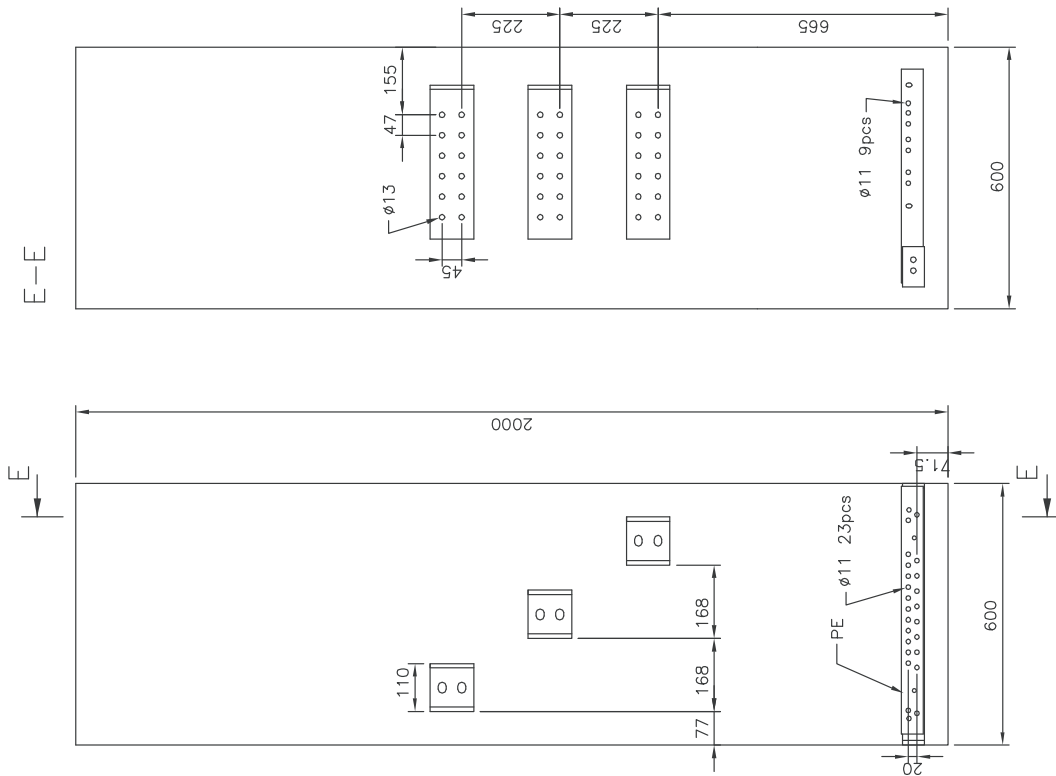

■ Cubicle width 600 mm, top cable exit

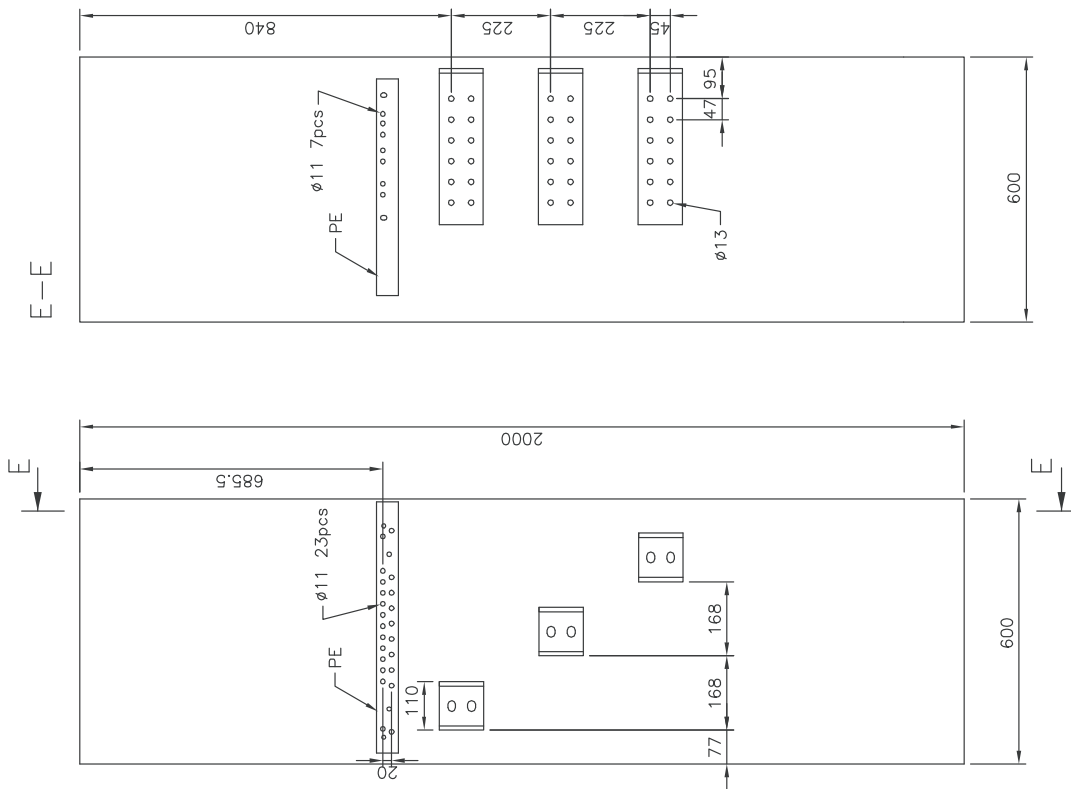

14

The Safe torque off function

What this chapter contains

This chapter describes the Safe torque off (STO) function of the inverter unit of the ACS880-07 and gives instructions for its use.

Description

The Safe torque off function can be used, for example, to construct safety or supervision circuits that stop the inverter in case of danger (such as an emergency stop circuit). Another possible application is a prevention of unexpected start-up switch that enables short-time maintenance operations like cleaning or work on non-electrical parts of the machinery without switching off the power supply to the inverter.

When activated, the Safe torque off function disables the control voltage of the power semiconductors of the inverter output stage (A, see diagram below), thus preventing the inverter from generating the torque required to rotate the motor. If the motor is running when Safe torque off is activated, it coasts to a stop.

The Safe torque off function has a redundant architecture, that is, both channels must be used in the safety function implementation. The safety data given in this manual is calculated for redundant use, and does not apply if both channels are not used.

The Safe torque off function of the inverter complies with these standards:

Standard	Name
EN 60204-1:2006 + AC:2010	<i>Safety of machinery – Electrical equipment of machines – Part 1: General requirements</i>
IEC 61326-3-1:2008	<i>Electrical equipment for measurement, control and laboratory use – EMC requirements – Part 3-1: Immunity requirements for safety-related systems and for equipment intended to perform safety-related functions (functional safety) – General industrial applications</i>

Standard	Name
IEC 61508-1:2010	<i>Functional safety of electrical/electronic/programmable electronic safety-related systems – Part 1: General requirements</i>
IEC 61508-2:2010	<i>Functional safety of electrical/electronic/programmable electronic safety-related systems – Part 2: Requirements for electrical/electronic/programmable electronic safety-related systems</i>
IEC 61511:2003	<i>Functional safety – Safety instrumented systems for the process industry sector</i>
IEC/EN 61800-5-2:2007	<i>Adjustable speed electrical power drive systems – Part 5-2: Safety requirements – Functional</i>
IEC/EN 62061:2005 + AC:2010	<i>Safety of machinery – Functional safety of safety-related electrical, electronic and programmable electronic control systems</i>
EN ISO 13849-1:2008 + AC:2009	<i>Safety of machinery – Safety-related parts of control systems – Part 1: General principles for design</i>
EN ISO 13849-2:2012	<i>Safety of machinery – Safety-related parts of control systems – Part 2: Validation</i>

The function also corresponds to Prevention of unexpected start-up as specified by EN 1037:1995 + A1:2008 and Uncontrolled stop (stop category 0) as specified in EN 60204-1:2006 + AC:2010.

■ Compliance with the European Machinery Directive

See section [Compliance with the European Machinery Directive](#) (page 193).

Wiring

The following diagrams present examples of Safe torque off wiring for

- a frame n×R8i inverter unit (page [252](#))
- multiple inverter units (page [253](#))
- multiple inverter units when an external 24 V DC power supply is used (page [254](#)).

For information on the specifications of the STO input, see section [Control unit connector data](#) (page [135](#)).

■ Activation switch

In the wiring diagrams below, the activation switch has the designation [K]. This represents a component such as a manually operated switch, an emergency stop push button switch, or the contacts of a safety relay or safety PLC.

- In case a manually operated activation switch is used, the switch must be of a type that can be locked out to the open position.
- The contacts of the switch or relay must open/close within 200 ms of each other.
- An FSO-xx safety functions module can also be used. For more information, see the FSO-xx module documentation.

■ Cable types and lengths

- Double-shielded twisted-pair cable is recommended.
- Maximum cable lengths:
 - 30 m (100 ft) between activation switch [K] and inverter control unit
 - 60 m (200 ft) between multiple inverter units
 - 60 m (200 ft) between external power supply and first inverter unit
 - 30 m (100 ft) between BCU control unit and last inverter module in the chain.

Note: The voltage at the INx terminals of each inverter control unit (or frame R8i inverter module) must be at least 17 V DC to be interpreted as “1”.

■ Grounding of protective shields

- Ground the shield in the cabling between the activation switch and the control unit at the control unit.
 - Ground the shield in the cabling between two control units at one control unit only.
 - Do not ground the shield in the cabling between BCU and inverter module, or between inverter modules.
-

■ Frame n×R8i inverter unit (internal power supply)

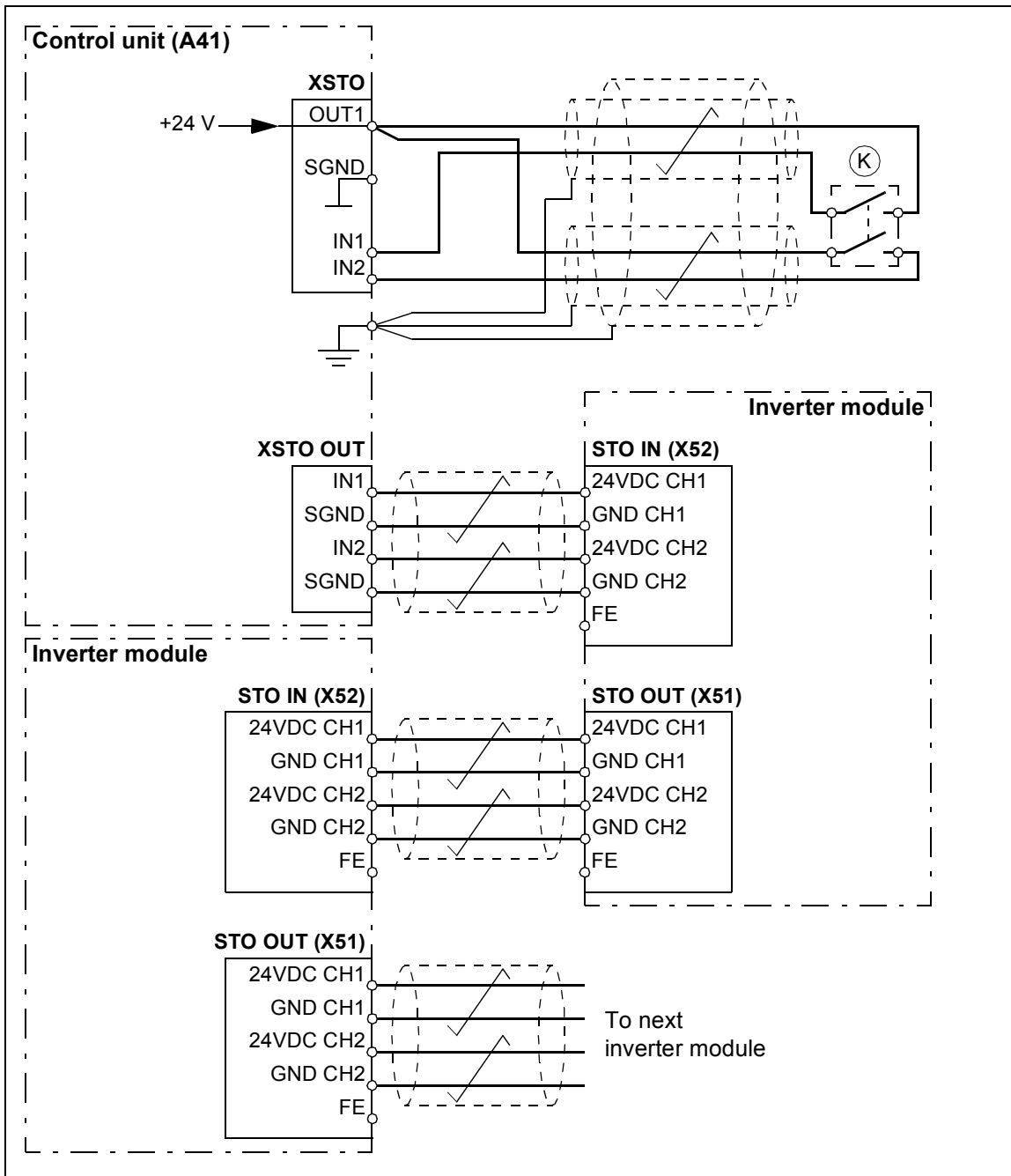

■ Multiple inverter units (internal power supply)

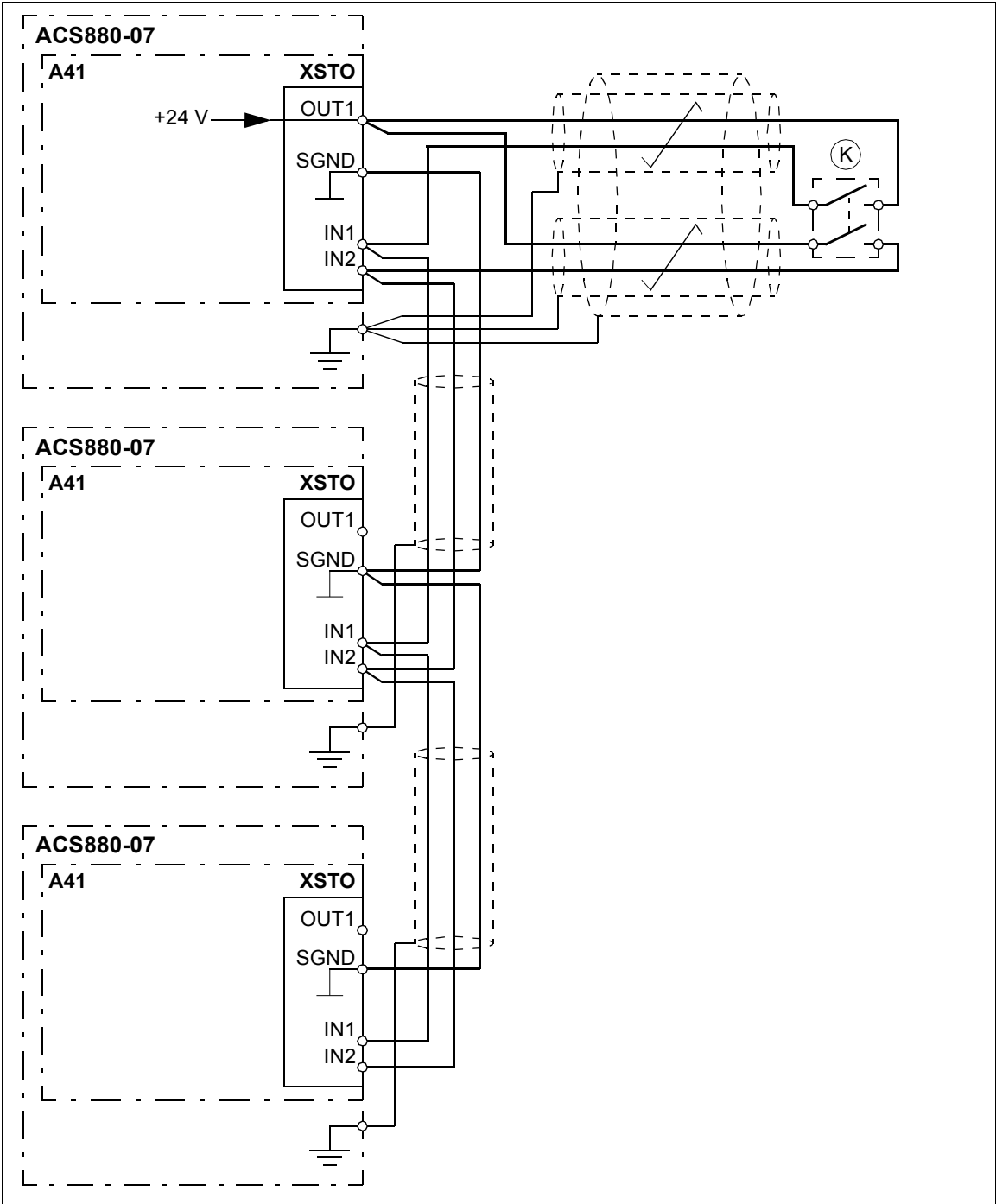

■ Multiple inverter units (external power supply)

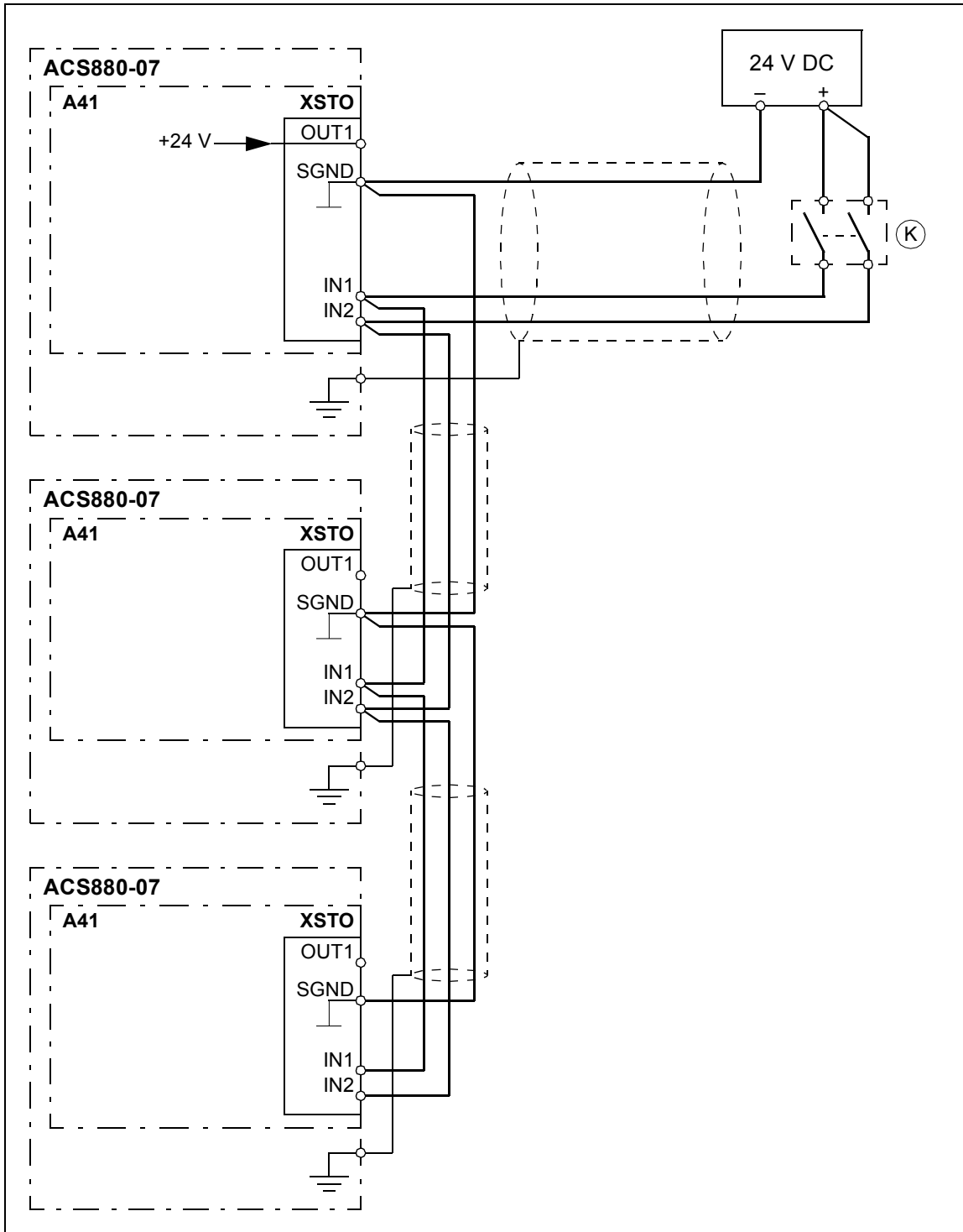

Operation principle

1. The Safe torque off activates (the activation switch is opened, or safety relay contacts open).
2. The STO inputs on the inverter control unit de-energize.
3. The control unit cuts off the control voltage from the inverter IGBTs.
4. The control program generates an indication as defined by parameter 31.22 (refer to the firmware manual of the inverter).
5. Motor coasts to a stop (if running). The inverter cannot restart while the activation switch or safety relay contacts are open. After the contacts close, a new start command is required to start the drive.

Start-up including acceptance test

To ensure the safe operation of a safety function, validation is required. The final assembler of the machine must validate the function by performing an acceptance test. The acceptance test must be performed

- at initial start-up of the safety function
- after any changes related to the safety function (circuit boards, wiring, components, settings, etc.)
- after any maintenance work related to the safety function.

■ Authorized person

The acceptance test of the safety function must be carried out by an authorized person with expertise and knowledge of the safety function. The test must be documented and signed by the authorized person.

■ Acceptance test reports

Signed acceptance test reports must be stored in the logbook of the machine. The report shall include documentation of start-up activities and test results, references to failure reports and resolution of failures. Any new acceptance tests performed due to changes or maintenance shall be logged into the logbook.

■ Acceptance test procedure

After wiring the Safe torque off function, validate its operation as follows.

Notes:

- If the inverter is equipped with safety option +Q951, +Q952, +Q957, +Q963 or +Q964, refer to the documentation of the option. If an FSO-xx safety functions module is installed, refer to its documentation.
- All inverter modules of the inverter unit must be powered and connected to the STO circuit during the acceptance test.

Action	<input checked="" type="checkbox"/>
 WARNING! Follow the safety instructions given in chapter Safety instructions (page 15). Ignoring the instructions can cause physical injury or death, or damage to the equipment.	<input type="checkbox"/>
Ensure that the inverter can be run and stopped freely during start-up.	<input type="checkbox"/>
Stop the inverter (if running), switch the input power off and isolate the inverter from the power line by a disconnecter.	<input type="checkbox"/>
Check the Safe torque off circuit connections against the wiring diagram.	<input type="checkbox"/>
Close the disconnecter and switch the power on.	<input type="checkbox"/>
Test the operation of the STO function when the motor is stopped. <ul style="list-style-type: none"> • Give a stop command for the inverter (if running) and wait until the motor shaft is at a standstill. Ensure that the inverter operates as follows: <ul style="list-style-type: none"> • Open the STO circuit. The inverter generates an indication if one is defined for 'stopped' state in parameter 31.22 (see the firmware manual). Give a start command to verify that the STO function blocks the inverter's operation. The motor should not start. Close the STO circuit. • Reset any active faults. Restart the inverter and check that the motor runs normally. 	<input type="checkbox"/>
Test the operation of the STO function when the motor is running. <ul style="list-style-type: none"> • Start the inverter and ensure the motor is running. • Open the STO circuit. The motor should stop. The inverter generates an indication if one is defined for 'running' state in parameter 31.22 (see the firmware manual). Reset any active faults and try to start the inverter. • Ensure that the motor stays at a standstill and the inverter operates as described above in testing the operation when the motor is stopped. Close the STO circuit. • Reset any active faults. Restart the inverter and check that the motor runs normally. 	<input type="checkbox"/>
Document and sign the acceptance test report which verifies that the safety function is safe and accepted for operation.	<input type="checkbox"/>

Use

1. Open the activation switch, or activate the safety functionality that is wired to the STO connection.
2. STO inputs on the inverter control unit de-energize, and the inverter control unit cuts off the control voltage from the inverter IGBTs.
3. The control program generates an indication as defined by parameter 31.22 (refer to the firmware manual of the inverter).
4. The motor coasts to a stop (if running). The inverter will not restart while the activation switch or safety relay contacts are open.
5. Deactivate the STO by closing the activation switch, or resetting the safety functionality that is wired to the STO connection.
6. Reset any faults before restarting.



WARNING! The Safe torque off function does not disconnect the voltage of the main and auxiliary circuits from the inverter. Therefore maintenance work on electrical parts of the inverter or the motor can only be carried out after isolating the inverter from the main supply.



WARNING! The Safe torque off functionality is only achieved through the XSTO connector of the inverter control unit (A41). True Safe torque off functionality is not achieved through the XSTO connectors of other control units (such as the supply control unit or the brake control unit).

The Safe torque off function is supported by the ACS880 inverter control program. It is not supported by supply or brake firmware.



WARNING! (With permanent magnet or synchronous reluctance [SynRM] motors only) In case of a multiple IGBT power semiconductor failure, the inverter system can produce an alignment torque which maximally rotates the motor shaft by $180/p$ (with permanent magnet motors) or $180/2p$ (with synchronous reluctance [SynRM] motors) degrees regardless of the activation of the Safe torque off function. p denotes the number of pole pairs.

Notes:

- If a running inverter is stopped by using the Safe torque off function, the inverter will cut off the motor supply voltage and the motor will coast to a stop. If this causes danger or is not otherwise acceptable, stop the inverter and machinery using the appropriate stop mode before activating the Safe torque off function.
 - The Safe torque off function overrides all other functions of the inverter unit.
 - The Safe torque off function is ineffective against deliberate sabotage or misuse.
 - The Safe torque off function has been designed to reduce the recognized hazardous conditions. In spite of this, it is not always possible to eliminate all potential hazards. The assembler of the machine must inform the final user about the residual risks.
-

Maintenance

After the operation of the circuit is validated at start-up, the STO function shall be maintained by periodic proof testing. In high demand mode of operation, the maximum proof test interval is 20 years. In low demand mode of operation, the maximum proof test interval is 2 years. The test procedure is given in section [Acceptance test procedure](#) (page 256).

In addition to proof testing, it is a good practice to check the operation of the function when other maintenance procedures are carried out on the machinery.

Include the Safe torque off operation test described above in the routine maintenance program of the machinery that the inverter runs.

If any wiring or component change is needed after start up, or the parameters are restored, follow the test given in section [Acceptance test procedure](#) (page 256).

Use only ABB approved spare parts.

Fault tracing

The indications given during the normal operation of the Safe torque off function are selected by inverter parameter 31.22.

The diagnostics of the Safe torque off function cross-compare the status of the two STO channels. In case the channels are not in the same state, a fault reaction function is performed and the inverter trips on an “STO hardware failure” fault. An attempt to use the STO in a non-redundant manner, for example activating only one channel, will trigger the same reaction.

See the inverter firmware manual for the indications generated by the inverter, and for details on directing fault and warning indications to an output on the control unit for external diagnostics.

Any failures of the Safe torque off function must be reported to ABB.

Safety data

The safety data for the Safe torque off function is given below.

Note: The safety data is calculated for redundant use, and does not apply if both STO channels are not used.

Frame size	SIL/SILCL	SC	PL	SFF (%)	PFH _D (T ₁ = 20 a) (1/h)	PFD (T ₁ = 2 a)	MTTF _d (a)	DC (%)	Cat.	HFT	CCF	Lifetime (a)
2×R8i	3	3	e	>99	5.57E-11	4.98E-07	19607	≥90	3	1	80	20
3×R8i	3	3	e	>99	6.39E-11	5.74E-07	15295	≥90	3	1	80	20
4×R8i	3	3	e	>99	7.22E-11	6.49E-07	12540	≥90	3	1	80	20
5×R8i	3	3	e	>99	8.05E-11	7.24E-07	10626	≥90	3	1	80	20

- The following temperature profile is used in safety value calculations:

- 670 on/off cycles per year with $\Delta T = 71.66$ °C
- 1340 on/off cycles per year with $\Delta T = 61.66$ °C
- 30 on/off cycles per year with $\Delta T = 10.0$ °C
- 32 °C board temperature at 2.0% of time
- 60 °C board temperature at 1.5% of time
- 85 °C board temperature at 2.3% of time.

- The STO is a type A safety component as defined in IEC 61508-2.

- Relevant failure modes:

- The STO trips spuriously (safe failure)
- The STO does not activate when requested

A fault exclusion on the failure mode “short circuit on printed circuit board” has been made (EN 13849-2, table D.5). The analysis is based on an assumption that one failure occurs at one time. No accumulated failures have been analyzed.

- STO reaction time (shortest detectable break): 1 ms
- STO response time: 2 ms (typical), 25 ms (maximum)
- Fault detection time: Channels in different states for longer than 200 ms
- Fault reaction time: Fault detection time + 10 ms
- STO fault indication (parameter 31.22) delay: < 500 ms
- STO warning indication (parameter 31.22) delay: < 1000 ms

■ Abbreviations

Abbr.	Reference	Description
Cat.	EN ISO 13849-1	Classification of the safety-related parts of a control system in respect of their resistance to faults and their subsequent behavior in the fault condition, and which is achieved by the structural arrangement of the parts, fault detection and/or by their reliability. The categories are: B, 1, 2, 3 and 4.
CCF	EN ISO 13849-1	Common cause failure (%)
DC	EN ISO 13849-1	Diagnostic coverage
FIT	IEC 61508	Failure in time: 1E-9 hours
HFT	IEC 61508	Hardware fault tolerance
MTTF _d	EN ISO 13849-1	Mean time to dangerous failure: (The total number of life units) / (the number of dangerous, undetected failures) during a particular measurement interval under stated conditions
PFD	IEC 61508	Probability of failure on demand

Abbr.	Reference	Description
PFH _D	IEC 61508	Probability of dangerous failures per hour
PL	EN ISO 13849-1	Performance level. Levels a...e correspond to SIL
SC	IEC 61508	Systematic capability
SFF	IEC 61508	Safe failure fraction (%)
SIL	IEC 61508	Safety integrity level (1...3)
SILCL	IEC/EN 62061	Maximum SIL (level 1...3) that can be claimed for a safety function or subsystem
SS1	IEC/EN 61800-5-2	Safe stop 1
STO	IEC/EN 61800-5-2	Safe torque off
T1	IEC 61508	Proof test interval. T1 is a parameter used to define the probabilistic failure rate (PFH or PFD) for the safety function or subsystem. Performing a proof test at a maximum interval of T1 is required to keep the SIL capability valid. The same interval must be followed to keep the PL capability (EN ISO 13849) valid. Note that any T1 values given cannot be regarded as a guarantee or warranty. See also section Maintenance (page 258).

■ Declaration of Conformity

See page [194](#).

15

Resistor braking

Contents of this chapter

This chapter tells how to select, protect and wire brake choppers and resistors. The chapter also contains the related technical data.

Operating principle

The brake chopper handles the energy generated by a decelerating motor. The chopper connects the brake resistor to the intermediate DC circuit whenever the voltage in the circuit exceeds the limit defined by the control program. Energy consumption by the resistor losses lowers the voltage until the resistor can be disconnected.

Factory-installed brake choppers and resistors

The following brake choppers (option +D150) and resistors (+D151) are available for the ACS880-07 (560...2800 kW) as factory-installed. It is also possible to use option +D150 with a custom resistor assembly.

U_N	ACS880-07 type	Brake chopper type (+D150)	Brake resistor type (+D151)
400 V	ACS880-07-0990A-3	2 × NBRA-659	2 × (2 × SAFUR180F460)
	ACS880-07-1140A-3		
	ACS880-07-1250A-3	3 × NBRA-659	3 × (2 × SAFUR180F460)
	ACS880-07-1480A-3		
	ACS880-07-1760A-3		
500 V	ACS880-07-0990A-5	2 × NBRA-659	2 × (2 × SAFUR200F500)
	ACS880-07-1070A-5		
	ACS880-07-1320A-5	3 × NBRA-659	3 × (2 × SAFUR200F500)
	ACS880-07-1450A-5		
	ACS880-07-1580A-5		
690 V	ACS880-07-0800A-7	3 × NBRA-669	3 × (2 × SAFUR200F500)
	ACS880-07-0900A-7		
	ACS880-07-0950A-7		
	ACS880-07-1160A-7		

Consult your local ABB representative for availability of brake choppers and resistors for other drive types.

Technical data

■ Ratings of chopper/resistor combinations

U_N	Chopper(s)	Resistors	R (ohm)	P_{brmax} (kW)	P_{brcont} (kW)	I_{max} (A)	Duty Cycle (10/60 s)		Duty Cycle (1/5 min)	
							P_{br} (kW)	I_{rms} (A)	P_{br} (kW)	I_{rms} (A)
400 V	2 × NBRA-659	2 × (2 × SAFUR180F460)	1.2	706	108	1090	575	888	333	514
	3 × NBRA-659	3 × (2 × SAFUR180F460)	1.2	1058	162	1635	862	1332	500	771
500 V	2 × NBRA-659	2 × (2 × SAFUR200F500)	1.35	806	108	1210	575	710	333	412
	3 × NBRA-659	3 × (2 × SAFUR200F500)	1.35	1208	162	1815	862	1065	500	618
690 V	2 × NBRA-669	2 × (2 × SAFUR200F500)	1.35	807	108	1670	575	514	333	298
	3 × NBRA-669	3 × (2 × SAFUR200F500)	1.35	1211	162	2505	862	771	500	447

U_N = Nominal voltage

R = Resistance of specified resistors (per chopper). This is also the minimum allowed resistance of the resistor assembly.

P_{brmax} = Maximum short-term (1 min every 10 mins) braking power

P_{brcont} = Maximum continuous braking power

I_{max} = Maximum peak current

P_{br} = Braking power for the specified duty cycle

I_{rms} = Corresponding rms current

■ SAFUR resistors

The SAFUR resistors available as factory-installed (option +D151) are also available separately.

Type	U_N (V)	R (ohm)	E_R (kJ)	P_{Rcont} (kW)	IPxx
SAFUR125F500	500	4.0	3600	9.0	IP00
SAFUR210F575	575	3.4	4200	10.5	IP00
SAFUR200F500	500	2.7	5400	13.5	IP00
SAFUR180F460	460	2.4	6000	15.0	IP00

U_N = Nominal voltage

R = Resistance

E_R = Short energy pulse that the resistor assembly will withstand each 400 seconds

P_{Rcont} = Continuous power (heat) dissipation of the resistor when placed correctly. Energy E_R dissipates in 400 seconds.

IPxx = Degree of protection

■ Terminals and cable lead-through data of factory-installed chopper/resistor cubicles

See the dimension drawings delivered with the unit.

Planning the braking system

■ Verifying the capacity of the braking equipment

1. Calculate the maximum power generated by the motor during braking (P_{\max}).
2. Ensure that the braking power of the chopper is equal to or greater than P_{\max} .

The P_{brmax} values specified in the ratings table on page 262 are for the reference braking cycle (1 minute of braking, 9 minutes of rest). If the actual duty cycle does not correspond to the reference cycle, the maximum allowed braking power (P_{br}) must be used instead. In the ratings table, P_{br} is given for two additional braking cycles. See below for instructions on calculating P_{br} for other braking cycles.

3. Check the resistor selection. The energy generated by the motor during a 400-second period must not exceed the heat dissipation capacity of the resistor (E_R).

If the E_R of the resistor is not sufficient, it is possible to use a four-resistor assembly in which two resistors are connected in parallel, two in series. The E_R value of the four-resistor assembly is four times that of a single resistor.

Custom resistors

Resistors other than those available as option +D151 can be used provided that

- the resistance is not lower than the value given in the ratings table (page 262)



WARNING! Never use a brake resistor with a resistance below the value specified for the particular drive / brake chopper / resistor combination. The drive and the chopper would not be able to handle the overcurrent caused by the low resistance.

- the resistance of the custom resistor does not restrict the braking capacity needed, ie.

$$P_{\max} < \frac{U_{\text{DC}}^2}{R}$$

where

P_{\max}	Maximum power generated by the motor during braking
U_{DC}	Voltage over the resistor during braking. U_{DC} equals 1.35 · 1.25 · 415 V DC (when supply voltage is 380 to 415 V AC) 1.35 · 1.25 · 500 V DC (when supply voltage is 440 to 500 V AC) or 1.35 · 1.25 · 690 V DC (when supply voltage is 525 to 690 V AC)
R	Resistor resistance (ohm)

- the heat dissipation capacity E_R of the resistor is sufficient for the application (see step 3 above).

Calculating the maximum braking power (P_{br})

- Braking energy transferred during any ten minute period must be less than or equal to the energy transferred during the reference braking cycle.
- The braking power must not exceed the rated maximum value P_{brmax} .

$$1. \quad n \times P_{br} \times t_{br} \leq P_{brmax} \times 60 \text{ s}$$

$$2. \quad P_{br} \leq P_{brmax}$$

n = Number of braking pulses during a 10-minute period

P_{br} = Maximum allowed braking power (kW)

t_{br} = Braking time (s)

P_{brmax} = Maximum braking power for a reference cycle (kW)

Example 1

The duration of a braking cycle is 30 minutes. The braking time is 15 minutes.

Result: If the braking time exceeds 10 minutes, the braking is considered continuous. The allowed continuous braking power is 10% of maximum braking power (P_{brmax}).

Example 2

The duration of a braking cycle (T) is three minutes. The braking time (t_{br}) is 40 seconds.

$$1. \quad P_{br} \leq \frac{P_{brmax} \times 60 \text{ s}}{4 \times 40 \text{ s}} = 0.375 \times P_{brmax}$$

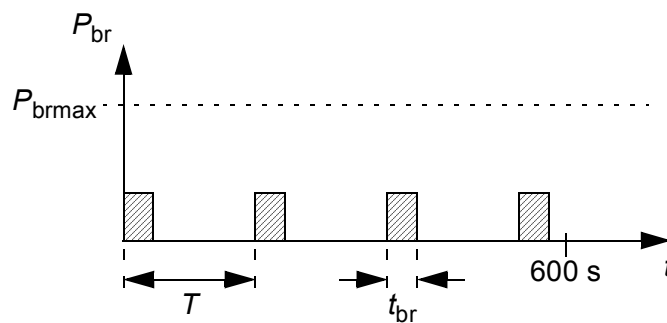

$$2. \quad P_{br} \leq P_{brmax} \quad \text{OK}$$

Result: The maximum allowed braking power for the cycle is 37% of the rated value given for the reference cycle.

■ Selecting and routing the cables of a custom resistor

Use the same cable type for the resistor cabling as for the drive input cabling to ensure that the input fuses also protect the resistor cable. Alternatively, a two conductor shielded cable with the same cross-sectional area can be used.

Minimizing electromagnetic interference

Follow these rules in order to minimize electromagnetic interference caused by the rapid current changes in the resistor cables:

- Shield the braking power line completely, either by using shielded cable or a metallic enclosure. Unshielded single-core cable can only be used if it is routed inside a cabinet that efficiently suppresses the radiated emissions.
- Install the cables away from other cable routes.
- Avoid long parallel runs with other cables. The minimum parallel cabling separation distance should be 0.3 meters (1 ft).
- Cross any other cables at right angles.
- Keep the cable as short as possible in order to minimize the radiated emissions and stress on chopper IGBTs. The longer the cable the higher the radiated emissions, inductive load and voltage peaks over the IGBT semiconductors of the brake chopper.

Maximum cable length

The maximum length of the resistor cable(s) is 50 m (164 ft).

EMC compliance of the complete installation

Note: ABB has not verified that the EMC requirements are fulfilled with custom brake resistors and cabling. The EMC compliance of the complete installation must be considered by the customer.

Placing custom brake resistors

Install the resistors outside the drive in a place where they are able to cool effectively.

Arrange the cooling of the resistor in a way that

- no danger of overheating is caused to the resistor or nearby materials, and
- the temperature of the room the resistor is located in does not exceed the allowed maximum.

Supply the resistor with cooling air/water according to the resistor manufacturer's instructions.



WARNING! The materials near the brake resistor must be non-flammable. The surface temperature of the resistor is high. The temperature of the air flowing from the resistor is hundreds of degrees Celsius. If the exhaust vents are connected to a ventilation system, ensure that the materials withstand high temperatures. Protect the resistor against contact.

■ Protecting the system against thermal overload

The brake chopper protects itself and the resistor cables against thermal overload when the cables are dimensioned according to the nominal current of the drive. By default, a brake chopper fault is wired to stop the supply unit of the drive.

Thermal protection of the resistors

The standard resistors available as option +D151 are equipped with a thermal switch. The switches of the resistors are wired in series and connected to the Enable input of the brake chopper. The relay output of the chopper is wired to the supply control unit so that a chopper fault condition stops the supply unit.

With custom resistors, a similar protection must be implemented. Use cable rated as follows:

- twisted pair, shielding recommended
- rated operating voltage between a conductor and ground ($U_0 \geq 750 \text{ V}$)
- insulation test voltage $> 2.5 \text{ kV}$.

Keep the cable as short as possible.

■ Protecting the resistor cable against short-circuits

The input fuses of the drive will also protect the resistor cable provided that the resistor cable is of the same type as the input cable.

Mechanical installation of custom brake resistors

Follow the resistor manufacturer's instructions.

Electrical installation of custom brake resistors

■ Connection diagram

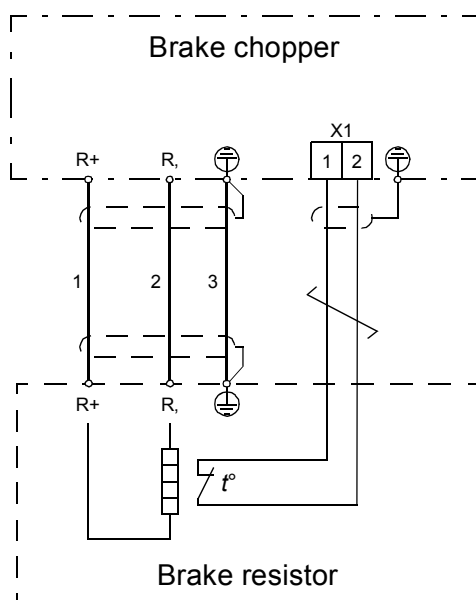

■ Connection procedure



WARNING! Obey the instructions in chapter [Safety instructions](#). If you ignore them, injury or death, or damage to the equipment can occur.

- Do the steps in section [Precautions before electrical work](#) on page 19 before you start the work.
- Connect the resistor cable at the resistor end only. If a shielded three-conductor cable is used, cut off the third conductor. Ground the twisted shield of the cable as well as any separate PE conductor (if present).
- At the chopper end of the cable, connect the R+ and R- conductors of the resistor cable together. Measure the insulation resistance between the combined conductors and the PE conductor by using a measuring voltage of 1 kV DC. The insulation resistance must be higher than 1 Mohm.

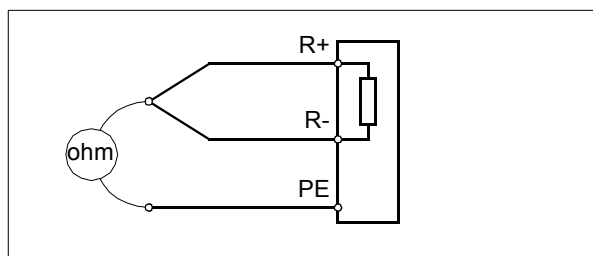

- Connect the resistor cable to the R+ and R- terminals of the chopper. If a shielded three-conductor cable is used, cut off the third conductor. Ground the twisted shield of the cable as well as any separate PE conductor (if present).
- Connect the thermal switch of the brake resistor to the enable input (X1) on the brake chopper control board. Use cable specified under [Thermal protection of the resistors](#) (page 267). If there are multiple thermal switches, connect them in series.



WARNING! The ENABLE input terminal block of the brake chopper is at intermediate circuit potential when the supply unit of the drive is running. This voltage is extremely dangerous and can cause serious damage or injury if the isolation level and protection conditions for the thermal switches are not sufficient. The thermal switches must always be properly insulated (over 2.5 kV) and shrouded against contact.

Start-up

Check the settings of the following inverter control program parameters (ACS880 primary control program):

- **30.30 Overvoltage control:** Overvoltage control disabled.

For settings of other control programs, see the appropriate firmware manual.

Note: New brake resistors may be coated with storage grease. As the brake chopper operates for the first time, the grease burns off and may produce some smoke. Make sure there is proper ventilation.

Further information

Product and service inquiries

Address any inquiries about the product to your local ABB representative, quoting the type designation and serial number of the unit in question. A listing of ABB sales, support and service contacts can be found by navigating to www.abb.com/searchchannels.

Product training

For information on ABB product training, navigate to new.abb.com/service/training.

Providing feedback on ABB Drives manuals

Your comments on our manuals are welcome. Navigate to new.abb.com/drives/manuals-feedback-form.

Document library on the Internet

You can find manuals and other product documents in PDF format on the Internet at www.abb.com/drives/documents.

Contact us

www.abb.com/drives

www.abb.com/drivespartners

3AUA0000143261 Rev C (EN) 2015-07-20